

**7300-R053-01**

SMONTAGOMME SERIE - TYRE-CHANGER SERIES -  
REIFENABMONTIERMASCHINEN SERIE -  
DÉMONTE-PNEU SÉRIE - DESMONTADORA DE NEUMÁTICOS SERIE  
**HP441 - HP641 - TC624 EASY - HP643 -  
G7441 - TC630 EASY - G7641 - T2210-2-PRO - G7645 - G8645 -  
GA2441 - GA2641**

LISTA DEI COMPONENTI Applicabile ai seguenti modelli  
LIST OF COMPONENTS Applicable to the following models  
LISTE DER KOMPONENTEN Gilt für die folgenden Modelle  
LISTE DES COMPOSANTS Applicable aux modèles suivants  
LISTA DE COMPONENTES Aplicabile a los siguientes modelos

**ROT.HP441.201102 - ROT.HP641.200938 - ROT.HP641.201034 - ROT.HP641.200891  
ROT.HP641.200785 - ROT.HP641.201003 - ROT.HP641.201768 - ROT.HP641.201072 - ROT.HP641.201065-  
ROT.HP641.201997 - ROT.HP643.200884 - ROT.HP643.201881 - ROT.HP643.201133 - ROT.HP643.200983 -  
RAV.G7441.201140 - RAV.G7441.200969 - RAV.G7441.201119 - RAV.G7441.200716  
RAV.G7441.200877 - RAV.G7441.200921 - RAV.G7641.200945 - RAV.G7641.200006  
RAV.G7641.201041 - RAV.G7641.200907 - RAV.G7641.200693 - RAV.G7641.201010 - RAV.G7641.201089  
RAV.G7641.200761 - RAV.G7645.201232 - RAV.G7645.200914 - RAV.G7645.200990 - RAV.G8645.201249  
SPA.GA441.200976 - SPA.GA441.201126 - SPA.GA441.202000 -  
SPA.GA641.201027 - SPA.GA641.201096 - SPA.GA641.200952 - SPA.GA641.201058 - SPA.GA645.200600**



**GLI ESPLOSI SERVONO SOLO PER L'IDENTIFICAZIONE DELLE PARTI DA SOSTITUIRE.  
LA SOSTITUZIONE DEVE ESSERE EFFETTUATA DA PERSONALE PROFESSIONALMENTE QUALIFICATO.**



**THE DIAGRAMS SERVE ONLY FOR THE IDENTIFICATION OF PARTS TO BE REPLACED.  
THE REPLACEMENT MUST BE CARRIED OUT PROFESSIONALLY QUALIFIED PERSONNEL.**



**DIE ZEICHNUNGEN DIENEN NUR ZUR IDENTIFIZIERUNG DER ERSATZTEILE. DIE ERSETZUNG  
MUSS DURCH QUALIFIZIERTES PERSONAL ERFOLGEN.**



**LES DESSINS NE SERVENT QU'À L'IDENTIFICATION DES PIÈCES À REMPLACER.  
LE REMPLACEMENT DOIT ÊTRE EFFECTUÉ PAR UN PERSONNE PROFESSIONNELLEMENT  
QUALIFIÉ.**



**LOS DIBUJOS EN DESPIECE SIRVEN ÚNICAMENTE PARA IDENTIFICAR LAS PIEZAS QUE DEBEN  
SUSTITUIRSE. LA SUSTITUCIÓN DE PIEZAS DEBE EFECTUARLA EXCLUSIVAMENTE PERSONAL  
PROFESIONALMENTE CUALIFICADO.**

- Per eventuali chiarimenti interpellare il più vicino rivenditore oppure rivolgersi direttamente a:
- For any further information please contact your local dealer or call:
- Im Zweifelsfall oder bei Rückfragen wenden Sie sich bitte an den nächsten Wiederverkäufer oder direkt an:
- Pour tout renseignement complémentaire s'adresser au revendeur le plus proche ou directement à:
- En caso de dudas, para eventuales aclaraciones, póngase en contacto con el distribuidor más próximo ó diríjase directamente a:

**VEHICLE SERVICE GROUP ITALY S.r.l**

Via Filippo Brunelleschi, 9 - 44020 Ostellato - Ferrara - Italy

Tel. (+39) 051 6781511 - Fax (+39) 051 846349 - e-mail: [aftersales.emea@vsgdoover.com](mailto:aftersales.emea@vsgdoover.com)







**SOMMARIO - SUMMARY - INHALT**  
**SOMMAIRE - SUMARIO**

<b>Tavola N°1A - Rev. 1 ..... 11</b> ASSIEME GENERALE MAIN ASSEMBLY GENERALSATZ ASSEMBLAGE GENERAL JUNTO GENERAL	<b>Tavola N°3C - Rev. 0 _ 730097720 ..... 48</b> KIT PALO POST KIT STANGENSET KIT POTEAU KIT PALO
<b>Tavola N°1B - Rev. 1 ..... 14</b> ASSIEME GENERALE MAIN ASSEMBLY GENERALSATZ ASSEMBLAGE GENERAL JUNTO GENERAL	<b>Tavola N°3D - Rev. 0 _ 730097540 ..... 51</b> KIT PALO POST KIT STANGENSET KIT POTEAU KIT PALO
<b>Tavola N°1C - Rev. 1 ..... 18</b> ASSIEME GENERALE MAIN ASSEMBLY GENERALSATZ ASSEMBLAGE GENERAL JUNTO GENERAL	<b>Tavola N°3E - Rev. 0 _ 730098990 ..... 55</b> KIT PALO POST KIT STANGENSET KIT POTEAU KIT PALO
<b>Tavola N°1D - Rev. 1 ..... 22</b> ASSIEME GENERALE MAIN ASSEMBLY GENERALSATZ ASSEMBLAGE GENERAL JUNTO GENERAL	<b>Tavola N°4A - Rev. 0 _ 730094172 ..... 60</b> GRUPPO COFANO LATERALE LATERAL CASING ASSEMBLY SEITLICHER HAUBESATZ ENSEMBLE COFFRE LATÉRAL CONJUNTO CAPOT LATERAL
<b>Tavola N°1E - Rev. 1 ..... 26</b> ASSIEME GENERALE MAIN ASSEMBLY GENERALSATZ ASSEMBLAGE GENERAL JUNTO GENERAL	<b>Tavola N°4B - Rev. 0 _ 730094221 ..... 62</b> GRUPPO COFANO LATERALE LATERAL CASING ASSEMBLY SEITLICHER HAUBESATZ ENSEMBLE COFFRE LATÉRAL CONJUNTO CAPOT LATERAL
<b>Tavola N°1F - Rev. 1..... 31</b> ASSIEME GENERALE MAIN ASSEMBLY GENERALSATZ ASSEMBLAGE GENERAL JUNTO GENERAL	<b>Tavola N°5A - Rev. 0 _ 730098470 ..... 64</b> KIT BRACCIO STALLONATORE BEAD BREAKER ARM KIT ABDRÜCKERARMSET KIT BRAS DÉCOLLE-PNEUS KIT BRAZO DESTALONADOR
<b>Tavola N°2A - Rev. 1 _ 730098460 ..... 35</b> GRUPPO TELAIO FRAME ASSEMBLY RAHMENSATZ ENSEMBLE CHÂSSIS CONJUNTO BASTIDOR	<b>Tavola N°5B - Rev. 0 _ 730097740 ..... 66</b> KIT BRACCIO STALLONATORE BEAD BREAKER ARM KIT ABDRÜCKERARMSET KIT BRAS DÉCOLLE-PNEUS KIT BRAZO DESTALONADOR
<b>Tavola N°2B - Rev. 0 _ 730098100 ..... 37</b> GRUPPO TELAIO FRAME ASSEMBLY RAHMENSATZ ENSEMBLE CHÂSSIS CONJUNTO BASTIDOR	<b>Tavola N°5C - Rev. 0 _ 730097600 ..... 68</b> KIT BRACCIO STALLONATORE BEAD BREAKER ARM KIT ABDRÜCKERARMSET KIT BRAS DÉCOLLE-PNEUS KIT BRAZO DESTALONADOR
<b>Tavola N°2C - Rev. 1 _ 730099670 ..... 39</b> KIT BASAMENTO CON INSERTI BASE KIT WITH INSERTS GRUNDPLATTENSET MIT EINSÄTZE KIT BÂTI AVEC RENFORTS KIT BASE CON INSERTOS	<b>Tavola N°6A - Rev. 0 _ 730098480 ..... 70</b> KIT CILINDRO STALLONATORE BEAD BREAKER CYLINDER KIT ABDRÜCKZYLINDERSET KIT CYLINDRE DÉCOLLE-PNEUS KIT CILINDRO DESTALONADOR
<b>Tavola N°3A - Rev. 0 _ 730098120 ..... 41</b> KIT PALO POST KIT STANGENSET KIT POTEAU KIT PALO	<b>Tavola N°6B - Rev. 1 _ 730098150 ..... 72</b> KIT CILINDRO STALLONATORE BEAD BREAKER CYLINDER KIT ABDRÜCKZYLINDERSET KIT CYLINDRE DÉCOLLE-PNEUS KIT CILINDRO DESTALONADOR
<b>Tavola N°3B - Rev. 0 _ 730098270 ..... 44</b> KIT PALO POST KIT STANGENSET KIT POTEAU KIT PALO	<b>Tavola N°6C - Rev. 0 _ 730097610 ..... 74</b> KIT CILINDRO STALLONATORE BEAD BREAKER CYLINDER KIT ABDRÜCKZYLINDERSET KIT CYLINDRE DÉCOLLE-PNEUS KIT CILINDRO DESTALONADOR

**Tavola N°7A - Rev. 0 \_\_ 140390221 ..... 76**

INSIEME DISTRIBUTORE ROTANTE  
ROTATING DISTRIBUTOR ASSEMBLY  
ROTATIONSVERTEILERSATZ  
ENSEMBLE DISTRIBUTEUR ROTATIF  
CONJUNTO DISTRIBUIDOR GIRATORIO

**Tavola N°7B - Rev. 0 \_\_ 140302093 ..... 78**

INSIEME DISTRIBUTORE ROTANTE  
ROTATING DISTRIBUTOR ASSEMBLY  
ROTATIONSVERTEILERSATZ  
ENSEMBLE DISTRIBUTEUR ROTATIF  
CONJUNTO DISTRIBUIDOR GIRATORIO

**Tavola N°8A - Rev. 1 \_\_ 730098290 ..... 80**

KIT MOTORIDUTTORE  
GEARMOTOR KIT  
UNTERSETZERSET  
KIT MOTORÉDUCTEUR  
KIT MOTORREDUCTOR

**Tavola N°8B - Rev. 0 \_\_ 730098140 ..... 82**

KIT MOTORIDUTTORE  
GEARMOTOR KIT  
UNTERSETZERSET  
KIT MOTORÉDUCTEUR  
KIT MOTORREDUCTOR

**Tavola N°8C - Rev. 0 \_\_ 730097570 ..... 85**

KIT MOTORIDUTTORE INVERTER  
INVERTER GEARMOTOR KIT  
FREQUENZUMFORMER-UNTERSETZERSET  
KIT MOTORÉDUCTEUR INVERSEUR  
KIT MOTORREDUCTOR INVERSOR

**Tavola N°8D - Rev. 1 \_\_ 730098590 ..... 88**

KIT MOTORIDUTTORE  
GEARMOTOR KIT  
UNTERSETZERSET  
KIT MOTORÉDUCTEUR  
KIT MOTORREDUCTOR

**Tavola N°9A - Rev. 0 \_\_ 730098300 ..... 90**

KIT PEDALIERA  
PEDALBOARD KIT  
PEDALSTEUERUNGSET  
KIT PÉDALIER  
KIT PEDALERA

**Tavola N°9B - Rev. 0 \_\_ 730098160 ..... 92**

KIT PEDALIERA  
PEDALBOARD KIT  
PEDALSTEUERUNGSET  
KIT PÉDALIER  
KIT PEDALERA

**Tavola N°9C - Rev. 0 \_\_ 730097620 ..... 94**

KIT PEDALIERA  
PEDALBOARD KIT  
PEDALSTEUERUNGSET  
KIT PÉDALIER  
KIT PEDALERA

**Tavola N°9D - Rev. 0 \_\_ 730098600 ..... 96**

KIT PEDALIERA  
PEDALBOARD KIT  
PEDALSTEUERUNGSET  
KIT PÉDALIER  
KIT PEDALERA

**Tavola N°10 - Rev. 0 \_\_ 140990391 ..... 98**

INSIEME PEDALE STALLONATORE  
BEAD BREAKER PEDAL ASSEMBLY  
ABDRÜCKPEDALSATZ  
ENSEMBLE PÉDALE DÉCOLLE-PNEUS  
CONJUNTO PEDAL DESTALONADOR

**Tavola N°11 - Rev. 0 \_\_ 140990401 ..... 100**

INSIEME PEDALE MANDRINO  
CHUCK PEDAL ASSEMBLY  
SPINDELPEDALSATZ  
ENSEMBLE PÉDALE MANDRIN  
CONJUNTO PEDAL MANDRIL

**Tavola N°12 - Rev. 0 \_\_ 140990431 ..... 102**

GRUPPO PEDALE  
PEDAL ASSEMBLY  
PEDALSATZ  
ENSEMBLE PÉDAL  
CONJUNTO PEDAL

**Tavola N°13A - Rev. 0 \_\_ 730098310 ..... 104**

PEDALE  
PEDAL  
PEDAL  
PÉDALE  
PEDAL

**Tavola N°13B - Rev. 0 \_\_ 730096820 ..... 107**

GRUPPO PEDALE CON INVERTER  
PEDAL ASSEMBLY WITH INVERTER  
PEDALSATZ MIT FREQUENZUMFORMER  
ENSEMBLE PÉDALE AVEC INVERSEUR  
CONJUNTO PEDAL CON INVERSOR

**Tavola N°13C - Rev. 0 \_\_ 730098640 ..... 109**

PEDALE ROTAZIONE MANDRINO  
CHUCK ROTATION PEDAL  
SPINDEL DREHUNGSPEDAL  
PÉDALE DE ROTATION MANDRIN  
PEDAL ROTACIÓN MANDRIL

**Tavola N°14A - Rev. 0 \_\_ 730094620 ..... 111**

MONTAGGIO MANDRINO QUADRO 10"-22"  
10"-22" SQUARE CHUCK ASSEMBLY  
MONTAGE DER QUADRATISCHEN SPINDEL 10"-22"  
MONTAGE MANDRIN CARRÉ 10"-22"  
MONTAJE MANDRIL CUADRADO 10"-22"

**Tavola N°14B - Rev. 1 \_\_ 730095501 ..... 113**

MANDRINO QUADRO 10"-24"  
10"-24" SQUARE CHUCK  
QUADRATISCHE SPINDEL 10"-24"  
MANDRIN CARRÉ 10"-24"  
MANDRIL CUADRADO 10"-24"

**Tavola N°14C - Rev. 0 \_\_ 730095491 ..... 116**

MONTAGGIO MANDRINO 10"-24"  
10"-24" CHUCK ASSEMBLY  
MONTAGE DER SPINDEL 10"-24"  
MONTAGE MANDRIN 10"-24"  
MONTAJE MANDRIL 10"-24"

**Tavola N°14D - Rev. 0 \_\_ 730094630 ..... 118**

MONTAGGIO MANDRINO QUADRO 10"-22"  
10"-22" SQUARE CHUCK ASSEMBLY  
MONTAGE DER QUADRATISCHEN SPINDEL 10"-22"  
MONTAGE MANDRIN CARRÉ 10"-22"  
MONTAJE MANDRIL CUADRADO 10"-22"

**Tavola N°14E - Rev. 0 \_\_ 730094811 ..... 120**

MONTAGGIO MANDRINO 10"-26"  
10"-26" CHUCK ASSEMBLY  
MONTAGE DER SPINDEL 10"-26"  
MONTAGE MANDRIN 10"-26"  
MONTAJE MANDRIL 10"-26"

**Tavola N°14F - Rev. 0 \_\_ 730094801 ..... 122**

MONTAGGIO MANDRINO 10"-26"  
10"-26" CHUCK ASSEMBLY  
MONTAGE DER SPINDEL 10"-26"  
MONTAGE MANDRIN 10"-26"  
MONTAJE MANDRIL 10"-26"

**Tavola N°14G - Rev. 0 \_730093190 ..... 125**

MONTAGGIO MANDRINO QUADRO 10"-20"  
10"-20" SQUARE CHUCK ASSEMBLY  
MONTAGE DER QUADRATISCHEN SPINDEL 10"-20"  
MONTAGE MANDRIN CARRÉ 10"-20"  
MONTAJE MANDRIL CUADRADO 10"-20"

**Tavola N°15A - Rev. 0 \_770790970 ..... 127**

PREMITALLONE PNEUMATICO  
PNEUMATIC BEAD PRESS  
PNEUMATISCHER WULSTABDRÜCKER  
POUSSE-TALON PNEUMATIQUE  
PRESIONATALÓN NEUMÁTICO

**Tavola N°15B - Rev. 0 \_770791000 ..... 129**

PREMITALLONE PNEUMATICO  
PNEUMATIC BEAD PRESS  
PNEUMATISCHER WULSTABDRÜCKER  
POUSSE-TALON PNEUMATIQUE  
PRESIONATALÓN NEUMÁTICO

**Tavola N°15C - Rev. 0 \_770791020 ..... 131**

PREMITALLONE PNEUMATICO  
PNEUMATIC BEAD PRESS  
PNEUMATISCHER WULSTABDRÜCKER  
POUSSE-TALON PNEUMATIQUE  
PRESIONATALÓN NEUMÁTICO

**Tavola N°15D - Rev. 0 \_PLUS73 ..... 133**

DISPOSITIVO PREMI-ALZA TALLONE PNEUMATICO  
PNEUMATIC BEAD PRESS/LIFT DEVICE  
PNEUMATISCHE WULSTABDRÜCK-HUBVORRICHTUNG  
DISPOSITIF POUSSE-LÈVE PNEU  
DISPOSITIVO PRESIONA-LEVANTATALÓN NEUMÁTICO

**Tavola N°16A - Rev. 0 \_770790980 ..... 135**

PREMITALLONE  
BEAD PRESS  
WULSTABDRÜCKER  
POUSSE-TALON  
PRESIONATALÓN

**Tavola N°16B - Rev. 0 \_770790990 ..... 138**

PREMITALLONE  
BEAD PRESS  
WULSTABDRÜCKER  
POUSSE-TALON  
PRESIONATALÓN

**Tavola N°16C - Rev. 0 \_770791010 ..... 142**

PREMITALLONE  
BEAD PRESS  
WULSTABDRÜCKER  
POUSSE-TALON  
PRESIONATALÓN

**Tavola N°17A - Rev. 1 \_730190010 ..... 145**

KIT CONDIZIONAMENTO ARIA  
AIR CONDITIONING KIT  
LUFT-KLIMATISIERUNGSSET  
KIT CONDITIONNEMENT AIR  
KIT ACONDICIONAMIENTO AIRE

**Tavola N°17B - Rev. 1 \_730190020 ..... 147**

KIT CONDIZIONAMENTO ARIA  
AIR CONDITIONING KIT  
LUFT-KLIMATISIERUNGSSET  
KIT CONDITIONNEMENT AIR  
KIT ACONDICIONAMIENTO AIRE

**Tavola N°17C - Rev. 1 \_730190030 ..... 149**

KIT CONDIZIONAMENTO ARIA  
AIR CONDITIONING KIT  
LUFT-KLIMATISIERUNGSSET  
KIT CONDITIONNEMENT AIR  
KIT ACONDICIONAMIENTO AIRE

**Tavola N°18A - Rev. 1 \_730097650 ..... 151**

PEDALE DI GONFIAGGIO  
INFLATION PEDAL  
AUFPUMPPEDALÛ  
PÉDALE DE GONFLAGE  
PEDAL DE INFLADO

**Tavola N°18B - Rev. 0 \_730097770 ..... 153**

KIT PEDALE DI GONFIAGGIO  
INFLATION PEDAL KIT  
AUFPUMPPEDALSET  
KIT PÉDALE DE GONFLAGE  
KIT PEDAL DE INFLADO

**Tavola N°19 - Rev. 0 \_730097660 ..... 155**

KIT MANOMETRO DI GONFIAGGIO  
INFLATION PRESSURE GAUGE KIT  
LUFTDRUCKMESSER-SET  
KIT MANOMÈTRE DE GONFLAGE  
KIT MANÓMETRO DE INFLADO

**Tavola N°20 - Rev. 0 \_730097780 ..... 157**

KIT SERBATOIO  
TANK KIT  
TANKSET  
KIT RÉSERVOIR  
KIT TANQUE

**Tavola N°21A - Rev. 0 \_140390790 ..... 159**

KIT SERBATOIO  
TANK KIT  
TANKSET  
KIT RÉSERVOIR  
KIT TANQUE

**Tavola N°21B - Rev. 0 \_730097520 ..... 161**

COPERTURA BASE PALO  
POST BASE COVER  
STANGENBODENABDECKUNG  
COUVERTURE EMBASE POTEAU  
COBERTURA BASE PALO

**Tavola N°22A - Rev. 0 \_140390580 ..... 163**

GRUPPO PROTEZIONE BASE PALO  
POST BASE PROTECTION ASSEMBLY  
STANGENBODEN-SCHUTZSATZ  
ENSEMBLE PROTECTION EMBASE POTEAU  
CONJUNTO PROTECCIÓN BASE PALO

**Tavola N°22B - Rev. 0 \_730098200 ..... 165**

COPERTURA PALO  
POST COVER  
STANGENABDECKUNG  
COUVERTURE POTEAU  
COBERTURA PALO

**Tavola N°23A - Rev. 0 \_730097530 ..... 167**

COPERTURA BASE PALO  
POST BASE COVER  
STANGENBODENABDECKUNG  
COUVERTURE EMBASE POTEAU  
COBERTURA BASE PALO

**Tavola N°23B - Rev. 0 \_730099860 ..... 169**

KIT COPERTURA BASE PALO  
POST BASE COVER KIT  
STANGENBODENABDECKUNGSSET  
KIT COUVERTURE EMBASE POTEAU  
KIT COBERTURA BASE PALO

**Tavola N°24A - Rev. 0 \_730097730 ..... 171**

COPERTURA BRACCIO  
ARM COVER  
ARMBECKUNG  
COUVERTURE BRAS  
COBERTURA BRAZO

**Tavola N°24B - Rev. 0 \_ 730098280 ..... 173**

COPERTURA BRACCIO  
ARM COVER  
ARMABDECKUNG  
COUVERTURE BRAS  
COBERTURA BRAZO

**Tavola N°24C - Rev. 0 \_ 730097550 ..... 175**

COPERTURA BRACCIO  
ARM COVER  
ARMABDECKUNG  
COUVERTURE BRAS  
COBERTURA BRAZO

**Tavola N°24D - Rev. 0 \_ 730097820 ..... 177**

COPERTURA BRACCIO  
ARM COVER  
ARMABDECKUNG  
COUVERTURE BRAS  
COBERTURA BRAZO

**Tavola N°25A - Rev. 0 \_ 730098130 ..... 179**

COPERTURA PALO  
POST COVER  
STANGENABDECKUNG  
COUVERTURE POTEAU  
COBERTURA PALO

**Tavola N°25B - Rev. 0 \_ 730097560 ..... 181**

COPERTURA PALO  
POST COVER  
STANGENABDECKUNG  
COUVERTURE POTEAU  
COBERTURA PALO

**Tavola N°25C - Rev. 0 \_ 730098210 ..... 183**

COPERTURA PALO  
POST COVER  
STANGENABDECKUNG  
COUVERTURE POTEAU  
COBERTURA PALO

**Tavola N°25D - Rev. 0 \_ 730097830 ..... 185**

COPERTURA PALO  
POST COVER  
STANGENABDECKUNG  
COUVERTURE POTEAU  
COBERTURA PALO

**Tavola N°26A - Rev. 0 \_ 730098110 ..... 187**

CARTER FRONTALE  
FRONT GUARD  
VORDERES GEHÄUSE  
CARTER FRONTAL  
CÁRTER ANTERIOR

**Tavola N°26B - Rev. 0 \_ 730097510 ..... 189**

CARTER FRONTALE  
FRONT GUARD  
VORDERES GEHÄUSE  
CARTER FRONTAL  
CÁRTER ANTERIOR

**Tavola N°27A - Rev. 0 \_ 730091270 ..... 191**

GRUPPO PISTONE RIBALTAMENTO PALO  
TILTING POST PISTON ASSEMBLY  
STANGENEINHEITSKIPPUNG-KOLBENSATZ  
ENSEMBLE PISTON BASCULAGE POTEAU  
CONJUNTO PISTÓN VUELCO PALO

**Tavola N°27B - Rev. 0 \_ 730092590 ..... 193**

GRUPPO CILINDRO RIBALTAMENTO  
TILTING CYLINDER ASSEMBLY  
ZYLINDERSKIPPUNGSATZ  
ENSEMBLE CYLINDRE BASCULAGE  
CONJUNTO CILINDRO VUELCO

**Tavola N°28 - Rev. 1 \_\_ 730096861 ..... 195**

GRUPPO INVERTER  
INVERTER ASSEMBLY  
FREQUENZUMFORMERSATZ  
ENSEMBLE INVERSEUR  
CONJUNTO INVERSOR

**Tavola N°29 - Rev. 0 \_\_ 770090370 ..... 197**

GRUPPO LIMITATORE DI CORSA  
STROKE LIMITING DEVICE ASSEMBLY  
HUBBEGRENZERSATZ  
ENSEMBLE LIMITEUR DE COURSE  
CONJUNTO LIMITADOR DE CARRERA

**Tavola N°30 - Rev. 0 \_\_ 770090410 ..... 199**

PORTAOGGETTI  
TOOL BOX  
OBJEKTTRÄGER  
PORTE-OBJETS  
PORTA-OBJETOS

**Tavola N°31A - Rev. 0 \_ 730097900 ..... 201**

KIT DOTAZIONE  
ACCESSORY KIT ASSEMBLY  
AUSSTATTUNGSSET  
KIT DOTATION  
KIT DOTACIÓN

**Tavola N°31B - Rev. 0 \_ 730097700 ..... 203**

KIT DOTAZIONE  
ACCESSORY KIT ASSEMBLY  
AUSSTATTUNGSSET  
KIT DOTATION  
KIT DOTACIÓN

**Tavola N°31C - Rev. 1 ..... 205**

KIT DOTAZIONE  
ACCESSORY KIT ASSEMBLY  
AUSSTATTUNGSSET  
KIT DOTATION  
KIT DOTACIÓN

**Tavola N°31D - Rev. 0 \_ 730097850 ..... 207**

KIT DOTAZIONE  
ACCESSORY KIT ASSEMBLY  
AUSSTATTUNGSSET  
KIT DOTATION  
KIT DOTACIÓN

**Tavola N°31E - Rev. 0 \_ 730099090 ..... 209**

KIT DOTAZIONE  
ACCESSORY KIT ASSEMBLY  
AUSSTATTUNGSSET  
KIT DOTATION  
KIT DOTACIÓN

**Tavola N°31F - Rev. 0 \_ 730098390 ..... 211**

KIT DOTAZIONE  
ACCESSORY KIT ASSEMBLY  
AUSSTATTUNGSSET  
KIT DOTATION  
KIT DOTACIÓN

**Tavola N°31G - Rev. 0 \_ 730098980 ..... 213**

KIT DOTAZIONE  
ACCESSORY KIT ASSEMBLY  
AUSSTATTUNGSSET  
KIT DOTATION  
KIT DOTACIÓN

**Tavola N°31H - Rev. 0 \_ 730099950 ..... 215**

KIT DOTAZIONE  
ACCESSORY KIT ASSEMBLY  
AUSSTATTUNGSSET  
KIT DOTATION  
KIT DOTACIÓN



**LISTA DEI COMPONENTI  
LIST OF COMPONENTS  
TEILELISTE  
LISTE DES PIÈCES DÉTACHÉES  
LISTA DE PIEZAS**

**Pag. 9 di 235**

SMONTAGOMME A PIATTO TILT BACK  
TILT BACK PLATE TYRE CHANGER  
TILT BACK SCHWENKBARE REIFENMONTIERMASCHINE  
DÉMONTÉ-PNEUS À PLATEAU TILT BACK  
DESMONTADORAS DE NEUMÁTICOS DE PLATO TILT BACK

**7300-R053-01**

**Tavola N°31I - Rev. 0 \_ 730190590 ..... 217**

*KIT DOTAZIONE  
ACCESSORY KIT ASSEMBLY  
AUSSTATTUNGSSET  
KIT DOTATION  
KIT DOTACIÓN*

**Tavola N°32A - Rev. 0 ..... 219**

*POSIZIONAMENTO TARGHETTE  
NAMEPLATES POSITIONING  
SCHILDERPOSITIONIERUNG  
POSITIONNEMENT PLAQUETTES  
POSICIONAMIENTO PLAQUITAS*

**Tavola N°32B - Rev. 2 ..... 221**

*POSIZIONAMENTO TARGHETTE  
NAMEPLATES POSITIONING  
SCHILDERPOSITIONIERUNG  
POSITIONNEMENT PLAQUETTES  
POSICIONAMIENTO PLAQUITAS*

**Tavola N°32C - Rev. 2 ..... 224**

*POSIZIONAMENTO TARGHETTE  
NAMEPLATES POSITIONING  
SCHILDERPOSITIONIERUNG  
POSITIONNEMENT PLAQUETTES  
POSICIONAMIENTO PLAQUITAS*

**Tavola N°32D - Rev. 0 ..... 227**

*POSIZIONAMENTO TARGHETTE  
NAMEPLATES POSITIONING  
SCHILDERPOSITIONIERUNG  
POSITIONNEMENT PLAQUETTES  
POSICIONAMIENTO PLAQUITAS*

**Tavola N°32E - Rev. 2 ..... 230**

*POSIZIONAMENTO TARGHETTE  
NAMEPLATES POSITIONING  
SCHILDERPOSITIONIERUNG  
POSITIONNEMENT PLAQUETTES  
POSICIONAMIENTO PLAQUITAS*

**Tavola N°32F - Rev. 1 ..... 233**

*POSIZIONAMENTO TARGHETTE  
NAMEPLATES POSITIONING  
SCHILDERPOSITIONIERUNG  
POSITIONNEMENT PLAQUETTES  
POSICIONAMIENTO PLAQUITAS*



NEL PRESENTE DOCUMENTO VIENE ADOTTATA LA SEGUENTE RAPPRESENTAZIONE GRAFICA:  
IN THIS DOCUMENT THE FOLLOWING GRAPHIC REPRESENTATION IS ADOPTED:  
IN DIESEM DOKUMENT WIRD DIE FOLGENDE GRAFISCHE DARSTELLUNG VERWENDET:  
DANS CE DOCUMENT, LA REPRÉSENTATION GRAPHIQUE SUIVANTE EST ADOPTÉE:  
EN ESTE DOCUMENTO, SE ADOPTA LA SIGUIENTE REPRESENTACIÓN GRÁFICA:



In questa colonna viene indicato il numero identificativo del componente sul disegno.  
This column indicates the component identification number on the drawing.  
Diese Reihe gibt die Komponentenidentifikationsnummer in der Zeichnung an.  
Cette colonne indique le numéro d'identification du composant sur le dessin.  
Esta columna indica el número de identificación del componente en el dibujo.



In questa colonna gli articoli disponibili come ricambio sono contrassegnati dal simbolo "✓".  
Items available as spare parts are marked with the symbol "✓" in this column.  
In dieser Reihe sind die als Ersatzteile verfügbaren Artikel mit dem Symbol "✓" gekennzeichnet.  
Dans cette colonne, les articles disponibles comme pièces de rechange sont marqués par le symbole "✓".  
En esta columna, los artículos disponibles como repuestos están marcados con el símbolo "✓".

**D.R**

In questa colonna viene indicato il disegno in cui viene esploso il componente e la sua eventuale revisione.  
This column indicates the drawing in which the component is exploded and its possible revision.  
Diese Reihe gibt die Zeichnung an, in der die Komponente explodiert ist, und ihre mögliche Revision.  
Cette colonne indique le dessin dans lequel le composant est éclaté et sa révision éventuelle.  
Esta columna indica el dibujo en el que se descompone el componente y su posible revisión.

**D.R**

Numero disegno	Indice di revisione
Number of drawing	Revision index
Zeichnungsnummer	Revisionsindex
Numéro de dessin	Index de révision
Número dibujo	Índice de revisión

**N**

In questa colonna viene indicato il codice identificativo del gruppo/componente.  
In this column the unit/component identification code is indicated.  
In diese Spalte wird den Gruppen-/Komponentenidentifikationscode angegeben.  
Cette colonne indique le code d'identification du groupe/composant.  
En esta columna se indica el código de identificación del grupo/componente.



Simbolo utilizzato per indicare un kit guarnizioni.

Symbol used to indicate a gasket kit.

Symbol zur Kennzeichnung eines Dichtungssatzes.

Symbole utilisé pour indiquer un kit de joints.

Simbolo utilizado para indicar un kit de juntas.



Simbolo utilizzato per indicare che il gruppo/componente è di serie.  
Symbol used to indicate that the assembly/component is standard.  
Symbol, das angibt, dass die Baugruppe/Komponente Standard ist.  
Symbole utilisé pour indiquer que le groupe/composant est standard.  
Simbolo utilizado para indicar que el conjunto/componente es estándar.

**OPT**

Simbolo utilizzato per indicare che il gruppo/componente è OPTIONAL.  
Symbol used to indicate that the assembly/component is OPTIONAL.  
Symbol, das angibt, dass die Baugruppe/Komponente OPTIONAL ist.  
Symbole utilisé pour indiquer que le groupe/composant est OPTIONNEL.  
Simbolo utilizado para indicar que el conjunto/componente es OPCIONAL.



Simbolo utilizzato per indicare il numero di matricola da cui è valida la tavola/componente.  
Symbol indicating the serial number from which the drawing/component is valid.  
Symbol zur Angabe der Seriennummer, ab der die Zeichnung/Komponente gültig ist.  
Symbole utilisé pour indiquer le numéro de série à partir duquel le dessin/composant est valide.  
Simbolo utilizado para indicar el número de serie a partir del cual se considera válido el dibujo/componente.



Simbolo utilizzato per indicare fino a quale numero di matricola è valida la tavola/componente.  
Symbol indicating the serial number up to which the drawing/component is valid.  
Symbol zur Angabe, bis zu welcher Seriennummer die Zeichnung/Komponente gültig ist.  
Symbole utilisé pour indiquer jusqu'à quel numéro de série le dessin/composant est valide.  
Simbolo utilizado para indicar hasta qué número de serie se considera válido el dibujo/componente.

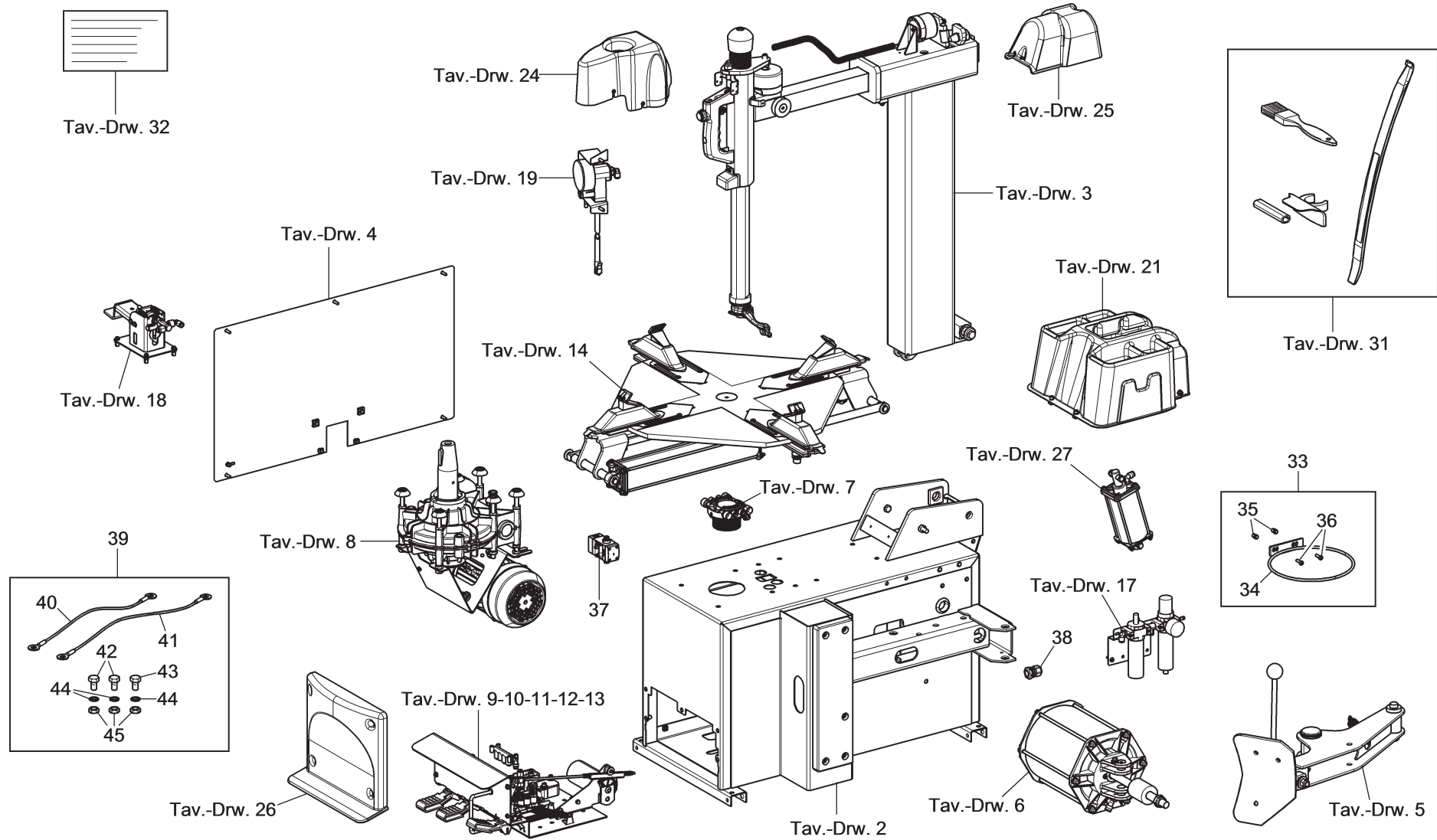

ROT.	HP441.201102	ROT.	HP641.200838	ROT.	HP641.201034	ROT.	HP641.200891	ROT.	HP641.200785	ROT.	HP641.201003	ROT.	HP641.201788	ROT.	HP641.201072	ROT.	HP641.201065	ROT.	HP641.201897	ROT.	HP643.200894	ROT.	HP643.201881	ROT.	HP643.201133	ROT.	HP643.200983	RAV.	G7441.201140	RAV.	G7441.200969	RAV.	G7441.201119	RAV.	G7441.200716	RAV.	G7441.200877	RAV.	G7441.200821	RAV.	G7641.200945	RAV.	G7641.200006	RAV.	G7641.201041	RAV.	G7641.200907	RAV.	G7641.200683	RAV.	G7641.201010	RAV.	G7641.201089	RAV.	G7641.200761	RAV.	G7645.201232	RAV.	G7645.200914	RAV.	G7645.200990	RAV.	G8645.201249	SPA.	GA441.200976	SPA.	GA441.201126	SPA.	GA441.202000	SPA.	GA641.201027	SPA.	GA641.201096	SPA.	GA641.200952	SPA.	GA641.201058	SPA.	GA645.200600
------	--------------	------	--------------	------	--------------	------	--------------	------	--------------	------	--------------	------	--------------	------	--------------	------	--------------	------	--------------	------	--------------	------	--------------	------	--------------	------	--------------	------	--------------	------	--------------	------	--------------	------	--------------	------	--------------	------	--------------	------	--------------	------	--------------	------	--------------	------	--------------	------	--------------	------	--------------	------	--------------	------	--------------	------	--------------	------	--------------	------	--------------	------	--------------	------	--------------	------	--------------	------	--------------	------	--------------	------	--------------	------	--------------	------	--------------	------	--------------



LISTA DEI COMPONENTI - LIST OF COMPONENTS - TEILELISTE  
 LISTE DES PIÈCES DÉTACHÉES - LISTA DE PIEZAS

Tavola N°1A - Rev. 1

ASSIEME GENERALE  
 MAIN ASSEMBLY  
 GENERALSATZ  
 ASSEMBLAGE GENERAL  
 JUNTO GENERAL



LISTA DEI COMPONENTI - LIST OF COMPONENTS - TEILELISTE  
LISTE DES PIÈCES DÉTACHÉES - LISTA DE PIEZAS

Tavola N°1A - Rev. 1

ASSIEME GENERALE  
MAIN ASSEMBLY  
GENERALSATZ  
ASSEMBLAGE GENERAL  
JUNTO GENERAL

Pag. 12 di 235

#		D.R	N	Descrizione	Description	Beschreibung	Description	Descripción		
---	--	-----	---	-------------	-------------	--------------	-------------	-------------	--	--

2	✓	2A.1	730098460	Gruppo telaio	Frame assembly	Rahmensatz	Ensemble châssis	Conjunto bastidor		
3	✓	3A.0	730098120	Kit palo	Post kit	Stangenset	Kit poteau	Kit palo		
4	✓	4A.0	730094172	Gruppo cofano laterale	Lateral casing assembly	Seitlicher Haubesatz	Ensemble coffre latéral	Conjunto capot lateral		
5	✓	5A.0	730098470	Kit braccio stallonatore	Bead breaker arm kit	Abdrückerarmset	Kit bras décolle-pneus	Kit brazo destalonador		
6	✓	6A.0	730098480	Kit cilindro stallonatore	Bead breaker cylinder kit	Abdrückzylinderset	Kit cylindre décolle-pneus	Kit cilindro destalonador		
7	✓	7A.0	140390221	Insieme distributore rotante	Rotating distributor assembly	Rotationsverteilersatz	Ensemble distributeur rotatif	Conjunto distribuidor giratorio		
8	✓	8A.1	730098290	Kit motoriduttore	Gearmotor kit	Untersetzerset	Kit motoréducteur	Kit motorreductor		
9	✓	9A.0	730098300	Kit pedaliera	Pedalboard kit	Pedalsteuerungset	Kit pédalier	Kit pedalera		
10	✓	10.0	140990391	Insieme pedale stallonatore	Bead breaker pedal assembly	Abdruckpedalsatz	Ensemble pédale décolle-pneus	Conjunto pedal destalonador		
11	✓	11.0	140990401	Insieme pedale mandrino	Chuck pedal assembly	Spindelpedalsatz	Ensemble pédale mandrin	Conjunto pedal mandril		
12	✓	12.0	140990431	Gruppo pedale	Pedal assembly	Pedalsatz	Ensemble pédal	Conjunto pedal		
13	✓	13A.0	730098310	Pedale	Pedal	Pedal	Pédale	Pedal		
14	✓	14A.0	730094620	Montaggio mandrino quadro 10"-22"	10"-22" square chuck assembly	Montage der quadratischen Spindel 10"-22"	Montage mandrin carré 10"-22"	Montaje mandril cuadrado 10"-22"		
17	✓	17A.1	730190010	Kit condizionamento aria	Air conditioning kit	Luft-Klimatisierungsset	Kit conditionnement air	Kit acondicionamiento aire		
18	✓	18A.1	730097650	Pedale di gonfiaggio	Inflation pedal	Aufpump pedal	Pédale de gonflage	Pedal de inflado		
19	✓	19.0	730097660	Kit manometro di gonfiaggio	Inflation pressure gauge kit	Luftdruckmesser-Set	Kit manomètre de gonflage	Kit manómetro de inflado		
21	✓	21A.0	140390790	Gruppo protezione base palo	Post base protection assembly	Stangenboden-Schutzsatz	Ensemble protection embase poteau	Conjunto protección base palo		
24	✓	24A.0	730097730	Copertura braccio	Arm cover	Armaddeckung	Couverture bras	Cobertura brazo		
25	✓	25A.0	730098130	Copertura palo	Post cover	Stangenabdeckung	Couverture poteau	Cobertura palo		
26	✓	26A.0	730098110	Carter frontale	Front guard	Vorderes Gehäuse	Carter frontal	Cárter anterior		
27	✓	27A.0	730091270	Gruppo pistone ribaltamento palo	Tilting post piston assembly	Stangeneinheitskipfung-Kolbensatz	Ensemble piston basculage poteau	Conjunto pistón vuelco palo		
31	✓	31A.0	730097900	Kit dotazione	Equipment kit	Ausstattungsset	Kit dotation	Kit dotación		
32		32A.0	-	Posizionamento targhette	Nameplates positioning	Schilderpositionierung	Positionnement plaquettes	Posicionamiento plaquitas		
33	✓		730095750	Gruppo anello portagrasso	Hose nipple ring assembly	Schmierringssatz	Ensemble anneau porte-tuyeau	Conjunto anillo porta-goma		
34	✓		730026380	Anello portagrasso	Grease-holder ring	Fetthaltering	Anneau porte-graisse	Anillo portagrassa		



LISTA DEI COMPONENTI - LIST OF COMPONENTS - TEILELISTE  
LISTE DES PIECES DETACHEES - LISTA DE PIEZAS

ASSIEME GENERALE  
MAIN ASSEMBLY  
GENERALSATZ  
ASSEMBLAGE GENERAL  
JUNTO GENERAL

Tavola N°1A - Rev. 1

#		D.R	N	Descrizione	Description	Beschreibung	Description	Descripción		
---	--	-----	---	-------------	-------------	--------------	-------------	-------------	--	--

35	✓		251107	Inserto filettato M6	M6 threaded insert	Gewindeinsatz M6	Renfort fileté M6	Inserto roscado M6		
36	✓		271021	TBEI M6x20	TBEI M6x20 bolt	Schraube TBEI M6x20	Vis TBEI M6x20	Tornillo TBEI M6x20		
37	✓		710590670	Gruppo valvola di gonfiaggio 60 PSI	60 PSI inflation valve assembly	Aufpumpventilsatz 60 PSI	Ensemble soupape de gonflage 60 PSI	Conjunto válvula de inflado 60 PSI		
38	✓		599074	Pressacavo	Cable press	Kabeldurchführung	Presse-câble	Prensaestopas		
39	✓		730098500	Kit messa a terra	Grounding kit	Erdungsset	Kit mise à la terre	Kit puesta a tierra		
40	✓		790065110	Cavo di terra	Ground cable	Erdkabel	Câble de masse	Cable tierra		
41	✓		790065160	Cavo di terra	Ground cable	Erdkabel	Câble de masse	Cable tierra		
42	✓		203208	TE M5x20	TE M5x20 bolt	Schraube TE M5x20	Vis TE M5x20	Tornillo TE M5x20		
43	✓		203124	TE M5x30	TE M5x30 bolt	Schraube TE M5x30	Vis TE M5x30	Tornillo TE M5x30		
44	✓		239017	Rosetta	Washer	Unterlegscheibe	Rondelle	Arandela		
45	✓		224005	Dado medio M5	M5 med nut	Mittlere Mutter M5	Écrou moyen M5	Tuerca media M5		

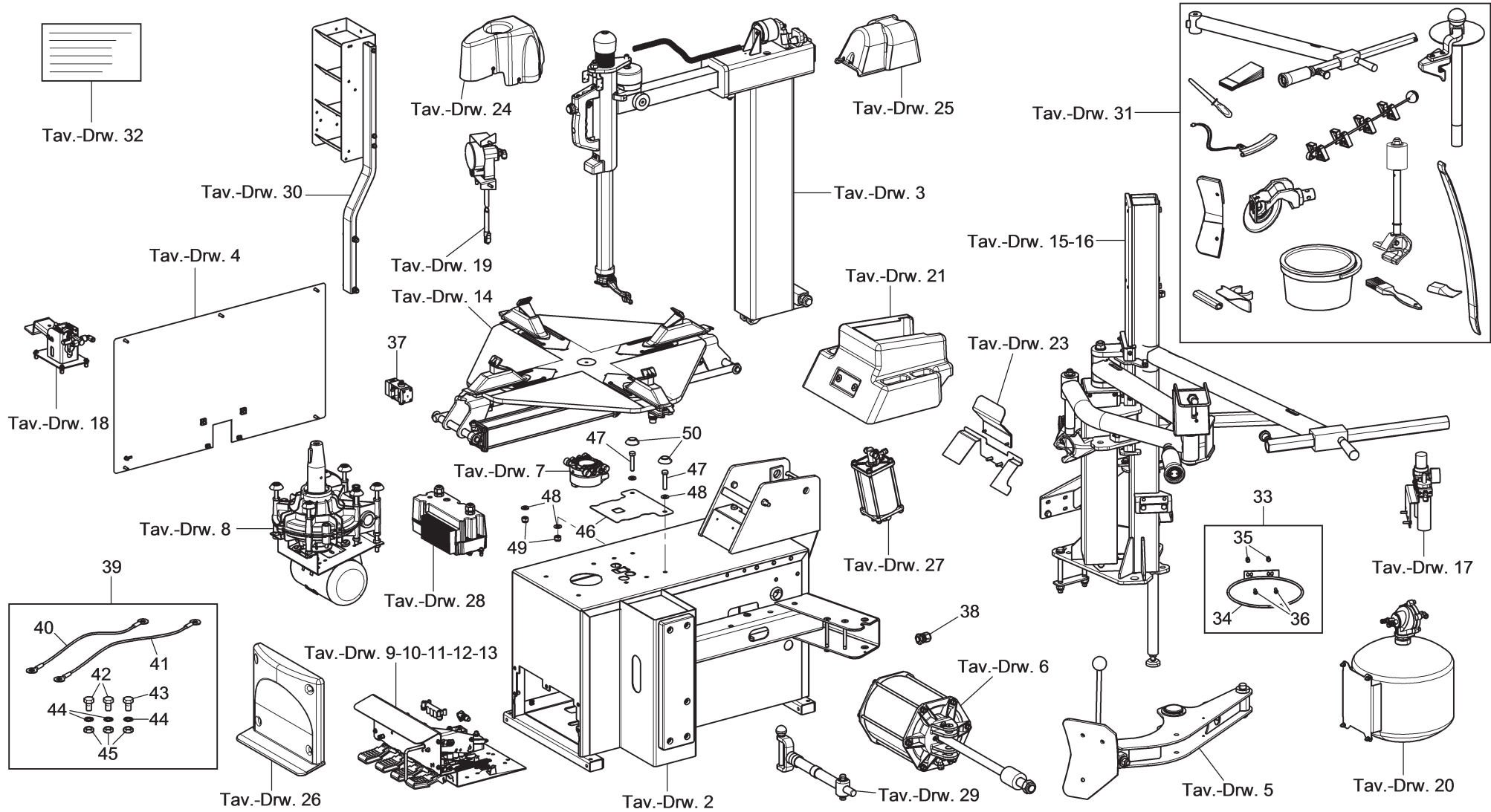

ROT. HP441.201102	ROT. HP641.200888	ROT. HP641.201034	ROT. HP641.200891	ROT. HP641.200785	ROT. HP641.201003	ROT. HP641.201788	ROT. HP641.201072	ROT. HP641.201065	ROT. HP641.201897	ROT. HP643.200894	ROT. HP643.201881	ROT. HP643.201133	ROT. HP643.200983	RAV. G7441.201140	RAV. G7441.200969	RAV. G7441.201119	RAV. G7441.200716	RAV. G7441.200877	RAV. G7441.200821	RAV. G7641.200945	RAV. G7641.200006	RAV. G7641.201041	RAV. G7641.200907	RAV. G7641.200683	RAV. G7641.201010	RAV. G7641.201089	RAV. G7641.200761	RAV. G7645.201232	RAV. G7645.200914	RAV. G7645.200990	RAV. G8645.201249	SPA. GA441.200976	SPA. GA441.201126	SPA. GA441.202000	SPA. GA641.201027	SPA. GA641.201096	SPA. GA641.200952	SPA. GA641.201058	SPA. GA645.200600				
•	•	•	•	•	•	•	•	•	•																																		
																				<b>LISTA DEI COMPONENTI - LIST OF COMPONENTS - TEILELISTE</b> <b>LISTE DES PIÈCES DÉTACHÉES - LISTA DE PIEZAS</b>										ASSIEME GENERALE MAIN ASSEMBLY GENERALSATZ ASSEMBLAGE GENERAL JUNTO GENERAL													
<b>Tavola N°1B - Rev. 1</b>																														<b>Pag. 14 di 235</b>													



LISTA DEI COMPONENTI - LIST OF COMPONENTS - TEILELISTE  
LISTE DES PIÈCES DÉTACHÉES - LISTA DE PIEZAS

Tavola N°1B - Rev. 1

ASSIEME GENERALE  
MAIN ASSEMBLY  
GENERSATZ  
ASSEMBLAGE GENERAL  
JUNTO GENERAL

Pag. 15 di 235

#	D.R.	N	Descrizione	Description	Beschreibung	Description	Descripción									→	→
								ROT.HP641.200938	ROT.HP641.201034	ROT.HP641.200891	ROT.HP641.200785	ROT.HP641.201003	ROT.HP641.201768	ROT.HP641.201072	ROT.HP641.201065		

2	✓	2B.0	730098100	Gruppo telaio	Frame assembly	Rahmensatz	Ensemble châssis	Conjunto bastidor	•	•	•	•	•	•	•	•	•		
3	✓	3A.0	730098120	Kit palo	Post kit	Stangenset	Kit poteau	Kit palo	•	•	•	•	•	•	•	•	•		
	✓	3B.0	730098270	Kit palo	Post kit	Stangenset	Kit poteau	Kit palo									•		
4	✓	4A.0	730094172	Gruppo cofano laterale	Lateral casing assembly	Seitlicher Haubesatz	Ensemble coffre latéral	Conjunto capot lateral	•	•	•	•	•	•	•	•	•		
5	✓	5B.0	730097740	Kit braccio stallonatore	Bead breaker arm kit	Abdrückerarmset	Kit bras décolle-pneus	Kit brazo destalonador	•	•	•	•	•	•	•	•	•		
6	✓	6B.1	730098150	Kit cilindro stallonatore	Bead breaker cylinder kit	Abdrückzylinderset	Kit cylindre décolle-pneus	Kit cilindro destalonador	•	•	•	•	•	•	•	•	•		
7	✓	7A.0	140390221	Insieme distributore rotante	Rotating distributor assembly	Rotationsverteilersatz	Ensemble distributeur rotatif	Conjunto distribuidor giratorio	•	•	•	•	•	•	•	•	•		
	✓	7B.0	140302093	Insieme distributore rotante	Rotating distributor assembly	Rotationsverteilersatz	Ensemble distributeur rotatif	Conjunto distribuidor giratorio		•							•		
8	✓	8A.1	730098290	Kit motoriduttore	Gearmotor kit	Untersetzersatz	Kit motoréducteur	Kit motorreductor					•	•	•	•	•		
	✓	8B.0	730098140	Kit motoriduttore	Gearmotor kit	Untersetzersatz	Kit motoréducteur	Kit motorreductor	•	•	•	•							
9	✓	9A.0	730098300	Kit pedaliera	Pedalboard kit	Pedalsteuerungset	Kit pédalier	Kit pedalera					•	•	•	•	•		
	✓	9B.0	730098160	Kit pedaliera	Pedalboard kit	Pedalsteuerungset	Kit pédalier	Kit pedalera	•	•	•	•							
10	✓	10.0	140990391	Insieme pedale stallonatore	Bead breaker pedal assembly	Abdrückpedalsatz	Ensemble pédale décolle-pneus	Conjunto pedal destalonador	•	•	•	•	•	•	•	•	•		
11	✓	11.0	140990401	Insieme pedale mandrino	Chuck pedal assembly	Spindelpedalsatz	Ensemble pédale mandrin	Conjunto pedal mandril	•	•	•	•	•	•	•	•	•		
12	✓	12.0	140990431	Gruppo pedale	Pedal assembly	Pedalsatz	Ensemble pédal	Conjunto pedal	•	•	•	•	•	•	•	•	•		
13	✓	13A.0	730098310	Pedale	Pedal	Pedal	Pédale	Pedal					•	•	•	•	•		
	✓	13B.0	730096820	Gruppo pedale con inverter	Pedal assembly with inverter	Pedalsatz mit Frequenzumformer	Ensemble pédale avec inverseur	Conjunto pedal con inversor	•	•	•	•							
14	✓	14A.0	730094620	Montaggio mandrino quadro 10"-22"	10"-22" square chuck assembly	Montage der quadratischen Spindel 10"-22"	Montage mandrin carré 10"-22"	Montaje mandril cuadrado 10"-22"					•	•	•	•	•		
	✓	14B.1	730095501	Mandrino quadro 10"-24"	10"-24" square chuck	Quadratische Spindel 10"-24"	Mandrin carré 10"-24"	Mandril cuadrado 10"-24"	•	•	•						•		
	✓	14C.0	730095491	Montaggio mandrino 10"-24"	10"-24" chuck assembly	Montage der Spindel 10"-24"	Montage mandrin 10"-24"	Montaje mandril 10"-24"		•									
	✓	14D.0	730094630	Montaggio mandrino quadro 10"-22"	10"-22" square chuck assembly	Montage der quadratischen Spindel 10"-22"	Montage mandrin carré 10"-22"	Montaje mandril cuadrado 10"-22"									•		
15	✓	15A.0	770790970	Premitalлоне pneumatico	Pneumatic bead press	Pneumatischer Wulstabdrücker	Pousse-talon pneumatique	Presionatalón neumático			•	•					•		
16	✓	16A.0	770790980	Premitalлоне	Bead press	Wulstabdrücker	Pousse-talon	Presionatalón			•	•					•		



LISTA DEI COMPONENTI - LIST OF COMPONENTS - TEILELISTE  
LISTE DES PIÈCES DÉTACHÉES - LISTA DE PIEZAS

Tavola N°1B - Rev. 1

ASSIEME GENERALE  
MAIN ASSEMBLY  
GENERSATZ  
ASSEMBLAGE GENERAL  
JUNTO GENERAL

Pag. 16 di 235

#	D.R.	N	Descrizione	Description	Beschreibung	Description	Descripción									T	T
								ROT.HP641.200938	ROT.HP641.201034	ROT.HP641.200891	ROT.HP641.200785	ROT.HP641.201003	ROT.HP641.201768	ROT.HP641.201072	ROT.HP641.201065		

17	✓	17A.1	730190010	Kit condizionamento aria	Air conditioning kit	Luft-Klimatisierungsset	Kit conditionnement air	Kit acondicionamiento aire	•	•	•	•	•	•	•	•	•		
	✓	17B.1	730190020	Kit condizionamento aria	Air conditioning kit	Luft-Klimatisierungsset	Kit conditionnement air	Kit acondicionamiento aire			•						•		
18	✓	18A.1	730097650	Pedale di gonfiaggio	Inflation pedal	Aufpump pedal	Pédale de gonflage	Pedal de inflado	•	•	•	•	•	•	•	•	•		
	✓	18B.0	730097770	Kit pedale di gonfiaggio	Inflation pedal kit	Aufpump pedaset	Kit pédale de gonflage	Kit pedal de inflado		•							•		
19	✓	19.0	730097660	Kit manometro di gonfiaggio	Inflation pressure gauge kit	Luftdruckmesser-Set	Kit manomètre de gonflage	Kit manómetro de inflado	•	•	•	•	•	•	•	•	•		
20	✓	20.0	730097780	Kit serbatoio	Tank kit	Tankset	Kit réservoir	Kit tanque		•						•			
21	✓	21B.0	730097520	Copertura base palo	Post base cover	Stangenbodenabdeckung	Couverture embase poteau	Cobertura base palo	•	•	•	•	•	•	•	•	•		
23	✓	23A.0	730097530	Copertura base palo	Post base cover	Stangenbodenabdeckung	Couverture embase poteau	Cobertura base palo	•	•	•	•	•	•	•	•	•		
24	✓	24A.0	730097730	Copertura braccio	Arm cover	Armabdeckung	Couverture bras	Cobertura brazo	•	•	•	•	•	•	•	•	•		
	✓	24B.0	730098280	Copertura braccio	Arm cover	Armabdeckung	Couverture bras	Cobertura brazo									•		
25	✓	25A.0	730098130	Copertura palo	Post cover	Stangenabdeckung	Couverture poteau	Cobertura palo	•	•	•	•	•	•	•	•	•		
26	✓	26A.0	730098110	Carter frontale	Front guard	Vorderes Gehäuse	Carter frontal	Cárter anterior	•	•	•	•	•	•	•	•	•		
27	✓	27B.0	730092590	Gruppo cilindro ribaltamento	Tilting cylinder assembly	Zylinderskippsatz	Ensemble cylindre basculage	Conjunto cilindro vuelco	•	•	•	•	•	•	•	•	•		
28	✓	28.1	730096861	Gruppo inverter	Inverter assembly	Frequenzumformersatz	Ensemble inverseur	Conjunto inversor	•	•	•	•							
29	✓	29.0	770090370	Gruppo limitatore di corsa	Stroke limiting device assembly	Hubbegrenzersatz	Ensemble limiteur de course	Conjunto limitador de carrera				•	•				•		
30	✓	30.0	770090410	Portaoggetti	Tool box	Objektträger	Porte-objets	Porta-objetos				•							
31	✓	31A.0	730097900	Kit dotazione	Equipment kit	Ausstattungsset	Kit dotation	Kit dotación	•	•			•	•	•				
	✓	31B.0	730097700	Kit dotazione	Equipment kit	Ausstattungsset	Kit dotation	Kit dotación			•						•		
		31C.1	-	Kit dotazione	Equipment kit	Ausstattungsset	Kit dotation	Kit dotación				•							
		31I	730190590	Kit dotazione	Equipment kit	Ausstattungsset	Kit dotation	Kit dotación										•	
32		32B.2	-	Posizionamento targhette	Nameplates positioning	Schilderpositionierung	Positionnement plaquettes	Posicionamiento plaquitas	•	•	•	•	•	•	•	•	•		
33	✓		730095750	Gruppo anello portagrasso	Hose nipple ring assembly	Schmierringssatz	Ensemble anneau portetuyeau	Conjunto anillo portagoma	•	•		•	•	•	•	•	•		
	✓		730097640	Kit portagrasso	Grease holder kit	Fetthaltersset	Kit porte-graisse	Kit soporte grasa			•						•		
34	✓		730026380	Anello portagrasso	Grease-holder ring	Fetthaltering	Anneau porte-graisse	Anillo portagrasa	•	•		•	•	•	•	•	•		
	✓		B0223000	Anello contenitore grasso	Grease holder ring	Fettführungsring	Anneau cuve porte-graisse	Anillo porta grasa			•						•		



LISTA DEI COMPONENTI - LIST OF COMPONENTS - TEILELISTE  
LISTE DES PIÈCES DÉTACHÉES - LISTA DE PIEZAS





Tavola N°1B - Rev. 1

ASSIEME GENERALE  
MAIN ASSEMBLY  
GENERSATZ  
ASSEMBLAGE GENERAL  
JUNTO GENERAL

Pag. 17 di 235

#	D.R.	N	Descrizione	Description	Beschreibung	Description	Descripción											→	→			
								ROT.HP641.200938	ROT.HP641.201034	ROT.HP641.200891	ROT.HP641.200785	ROT.HP641.201003	ROT.HP641.201768	ROT.HP641.201072	ROT.HP641.201065	ROT.HP641.201997						
35	✓		251107	Inserto filettato M6	M6 threaded insert	Gewindeinsatz M6	Renfort fileté M6	Inserto roscado M6	•	•	•	•	•	•	•	•	•	•	•	•		
36	✓		271021	TBEI M6x20	TBEI M6x20 bolt	Schraube TBEI M6x20	Vis TBEI M6x20	Tornillo TBEI M6x20	•	•		•	•	•	•	•	•					
	✓		272172	TE M8x16	TE M8x16 bolt	Schraube TE M8x16	Vis TE M8x16	Tornillo TE M8x16			•							•				
37	✓		710590670	Gruppo valvola di gonfiaggio 60 PSI	60 PSI inflation valve assembly	Aufpumpventilsatz 60 PSI	Ensemble soupape de gonflage 60 PSI	Conjunto válvula de inflado 60 PSI	•	•	•	•	•	•	•	•	•	•	•	•		
38	✓		599074	Pressacavo	Cable press	Kabeldurchführung	Presse-câble	Prensaestopas	•	•	•	•	•	•	•	•	•	•	•	•		
39	✓		730098180	Kit messa a terra	Grounding kit	Erdungsset	Kit mise à la terre	Kit puesta a tierra	•	•	•	•										
	✓		730098330	Kit messa a terra	Grounding kit	Erdungsset	Kit mise à la terre	Kit puesta a tierra					•	•	•	•	•	•	•	•		
40	✓		790065110	Insieme invertitore con cavi	Inverter with cables assembly	Frequenzumformersatz mit Kabeln	Ensemble inverseur avec câbles	Conjunto inversor con cables	•	•	•	•	•	•	•	•	•	•	•	•		
41	✓		790065160	Insieme cavo alimentazione inverter	Inverter supply cable assembly	Frequenzumformer-Stromkabelsatz	Ensemble câble alimentation inverseur	Conjunto cable alimentación inversor	•	•	•	•	•	•	•	•	•	•	•	•		
42	✓		203208	TE M5x20	TE M5x20 bolt	Schraube TE M5x20	Vis TE M5x20	Tornillo TE M5x20	•	•	•	•	•	•	•	•	•	•	•	•		
43	✓		203124	TE M5x30	TE M5x30 bolt	Schraube TE M5x30	Vis TE M5x30	Tornillo TE M5x30	•	•	•	•	•	•	•	•	•	•	•	•		
44	✓		239017	Rosetta	Washer	Unterlegscheibe	Rondelle	Arandela	•	•	•	•	•	•	•	•	•	•	•	•		
45	✓		224005	Dado medio M5	M5 med nut	Mittlere Mutter M5	Écrou moyen M5	Tuerca media M5	•	•	•	•	•	•	•	•	•	•	•	•		
46	✓		730026450	Carter superiore per telaio	Upper guard for frame	Oberes Gehäuse für Rahmen	Carter supérieur pour châssis	Cárter superior para bastidor					•	•						•		
47	✓		203066	TE M10x50	Bolt TE M10x50	Schraube TE M10x50	Vis TE M10x50	Tornillo TE M10x50					•	•						•		
48	✓		236007	Rondella piana 10,5x21x2	Flat washer 10.5x21x2	Ebene Unterlagsscheibe 10,5x21x2	Rondelle Fe 10,5x21x2	Arandela Fe 10,5x21x2					•	•						•		
49	✓		228012	Dado autobloccante M10	Self-locking nut M10	Selbstsichernde Mutter M10	Écrou auto-bloquant M10	Tuerca autoblocante M10					•	•						•		
50	✓		730015400	Tappo protezione	Protection plug	Schutzstöpsel	Bouchon protection	Tapón protección					•	•						•		



				<b>LISTA DEI COMPONENTI - LIST OF COMPONENTS - TEILELISTE</b> <b>LISTE DES PIÈCES DÉTACHÉES - LISTA DE PIEZAS</b>				ASSIEME GENERALE MAIN ASSEMBLY GENERALSATZ ASSEMBLAGE GENERAL JUNTO GENERAL				<b>Pag. 19 di 235</b>			
				<b>Tavola N°1C - Rev. 1</b>											
#		D.R	N	Descrizione	Description	Beschreibung	Description	Descripción	ROT.HP643.200884	ROT.HP643.201881	ROT.HP643.201133	ROT.HP643.200883			

2	✓	2C.1	730099670	Kit basamento con inserti	Base kit with inserts	Grundplattenset mit Einsätze	Kit bâti avec renforts	Kit base con insertos	•	•	•	•		
3	✓	3C.0	730097720	Kit palo	Post kit	Stangenset	Kit poteau	Kit palo	•	•	•			
	✓	3D.0	730097540	Kit palo	Post kit	Stangenset	Kit poteau	Kit palo			•			
4	✓	4A.0	730094172	Gruppo cofano laterale	Lateral casing assembly	Seitlicher Haubesatz	Ensemble coffre latéral	Conjunto capot lateral	•	•	•	•		
5	✓	5B.0	730097740	Kit braccio stallonatore	Bead breaker arm kit	Abdrückerarmset	Kit bras décolle-pneus	Kit brazo destalonador	•	•	•			
	✓	5C.0	730097600	Kit braccio stallonatore	Bead breaker arm kit	Abdrückerarmset	Kit bras décolle-pneus	Kit brazo destalonador			•			
6	✓	6C.0	730097610	Kit cilindro stallonatore	Bead breaker cylinder kit	Abdrückzylinderset	Kit cylindre décolle-pneus	Kit cilindro destalonador	•	•	•	•		
7	✓	7A.0	140390221	Insieme distributore rotante	Rotating distributor assembly	Rotationsverteilersatz	Ensemble distributeur rotatif	Conjunto distribuidor giratorio	•	•		•		
	✓	7B.0	140302093	Insieme distributore rotante	Rotating distributor assembly	Rotationsverteilersatz	Ensemble distributeur rotatif	Conjunto distribuidor giratorio			•			
8	✓	8C.0	730097570	Kit motoriduttore inverter	Inverter gearmotor kit	Frequenzumformer-Untersetzer	Kit motoréducteur inverseur	Kit motorreductor inversor	•	•	•	•		
9	✓	9C.0	730097620	Kit pedaliera	Pedalboard kit	Pedalsteuerungset	Kit pédalier	Kit pedalera	•	•	•	•		
10	✓	10.0	140990391	Insieme pedale stallonatore	Bead breaker pedal assembly	Abdrückpedalsatz	Ensemble pédale décolle-pneus	Conjunto pedal destalonador	•	•	•	•		
11	✓	11.0	140990401	Insieme pedale mandrino	Chuck pedal assembly	Spindelpedalsatz	Ensemble pédale mandrin	Conjunto pedal mandril	•	•	•	•		
12	✓	12.0	140990431	Gruppo pedale	Pedal assembly	Pedalsatz	Ensemble pédal	Conjunto pedal	•	•	•	•		
13	✓	13B.0	730096820	Gruppo pedale con inverter	Pedal assembly with inverter	Pedalsatz mit Frequenzumformer	Ensemble pédale avec inverseur	Conjunto pedal con inversor	•	•	•	•		
14	✓	14E.0	730094811	Montaggio mandrino 10"-26"	10"-26" chuck assembly	Montage der Spindel 10"-26"	Montage mandrin 10"-26"	Montaje mandril 10"-26"	•	•		•		
	✓	14F.0	730094801	Montaggio mandrino 10"-26"	10"-26" chuck assembly	Montage der Spindel 10"-26"	Montage mandrin 10"-26"	Montaje mandril 10"-26"			•			
15	✓	15A.0	770790970	Premitalлоне pneumatico	Pneumatic bead press	Pneumatischer Wulstabdrücker	Pousse-talon pneumatique	Presionatalón neumático	•	•	•	•		
16	✓	16A.0	770790980	Premitalлоне	Bead press	Wulstabdrücker	Pousse-talon	Presionatalón	•	•	•	•		
17	✓	17B.1	730190020	Kit condizionamento aria	Air conditioning kit	Luft-Klimatisierungsset	Kit conditionnement air	Kit acondicionamiento aire	•	•	•	•		
18	✓	18A.1	730097650	Pedale di gonfiaggio	Inflation pedal	Aufpumpedal	Pédale de gonflage	Pedal de inflado	•	•		•		
	✓	18B.0	730097770	Kit pedale di gonfiaggio	Inflation pedal kit	Aufpumppedalset	Kit pédale de gonflage	Kit pedal de inflado			•			
19	✓	19.0	730097660	Kit manometro di gonfiaggio	Inflation pressure gauge kit	Luftdruckmesser-Set	Kit manomètre de gonflage	Kit manómetro de inflado	•	•	•	•		
20	✓	20.0	730097780	Kit serbatoio	Tank kit	Tankset	Kit réservoir	Kit tanque			•			



LISTA DEI COMPONENTI - LIST OF COMPONENTS - TEILELISTE  
LISTE DES PIÈCES DÉTACHÉES - LISTA DE PIEZAS

Tavola N°1C - Rev. 1

ASSIEME GENERALE  
MAIN ASSEMBLY  
GENERALSATZ  
ASSEMBLAGE GENERAL  
JUNTO GENERAL

Pag. 20 di 235

#	D.R.	N	Descrizione	Description	Beschreibung	Description	Descripción	ROT.HP643.200884	ROT.HP643.201881	ROT.HP643.201133	ROT.HP643.200983		
												→	→

21	✓	21B.0	730097520	Copertura base palo	Post base cover	Stangenbodenabdeckung	Couverture embase poteau	Cobertura base palo	•	•	•	•		
23	✓	23A.0	730097530	Copertura base palo	Post base cover	Stangenbodenabdeckung	Couverture embase poteau	Cobertura base palo	•	•	•	•		
24	✓	24A.0	730097730	Copertura braccio	Arm cover	Armaddeckung	Couverture bras	Cobertura brazo	•	•	•	•		
	✓	24C.0	730097550	Copertura braccio	Arm cover	Armaddeckung	Couverture bras	Cobertura brazo				•		
25	✓	25B.0	730097560	Copertura palo	Post cover	Stangenabdeckung	Couverture poteau	Cobertura palo	•	•	•	•		
26	✓	26B.0	730097510	Carter frontale	Front guard	Vorderes Gehäuse	Carter frontal	Cárter anterior	•	•	•	•		
27	✓	27B.0	730092590	Gruppo cilindro ribaltamento	Tilting cylinder assembly	Zylinderskippsatz	Ensemble cylindre basculage	Conjunto cilindro vuelco	•	•	•	•		
28	✓	28.1	730096861	Gruppo inverter	Inverter assembly	Frequenzumformersatz	Ensemble inverseur	Conjunto inversor	•	•	•	•		
29	✓	29.0	770090370	Carter frontale	Front guard	Vorderes Gehäuse	Carter frontal	Cárter anterior	•	•	•	•		
31	✓	31B.0	730097700	Kit dotazione	Equipment kit	Ausstattungsset	Kit dotation	Kit dotación	•	•	•	•		
32		32C.2	-	Posizionamento targhette	Nameplates positioning	Schilderpositionierung	Positionnement plaquettes	Posicionamiento plaquitas	•	•	•	•		
33	✓		730097640	Kit portagrasso	Grease holder kit	Fetthalterset	Kit porte-graisse	Kit soporte grasa	•	•	•	•		
34	✓		B0223000	Anello contenitore grasso	Grease holder ring	Fettführungsring	Anneau cuve porte-graisse	Anillo porta grasa	•	•	•	•		
35	✓		272172	VTE M8x16	TE M8x16 bolt	Schraube TE M8x16	Vis TE M8x16	Tornillo TE M8x16	•	•	•	•		
36	✓		710590670	Gruppo valvola di gonfiaggio 60 PSI	60 PSI inflation valve assembly	Aufpumpventilsatz 60 PSI	Ensemble soupape de gonflage 60 PSI	Conjunto válvula de inflado 60 PSI	•	•	•	•		
37	✓		599074	Pressacavo	Cable press	Kabeldurchführung	Presse-câble	Prensaestopas	•	•	•	•		
38	✓		730097670	Kit messa a terra	Grounding kit	Erdungsset	Kit mise à la terre	Kit puesta a tierra	•	•	•	•		
39	✓		790065110	Cavo di terra	Ground cable	Erdkabel	Câble de masse	Cable tierra	•	•	•	•		
40	✓		790065160	Cavo di terra	Ground cable	Erdkabel	Câble de masse	Cable tierra	•	•	•	•		
41	✓		203208	TE M5x20	TE M5x20 bolt	Schraube TE M5x20	Vis TE M5x20	Tornillo TE M5x20	•	•	•	•		
42	✓		203124	TE M5x30	TE M5x30 bolt	Schraube TE M5x30	Vis TE M5x30	Tornillo TE M5x30	•	•	•	•		
43	✓		239017	Rosetta	Washer	Unterlegscheibe	Rondelle	Arandela	•	•	•	•		
44	✓		224005	Dado medio M5	M5 med nut	Mittlere Mutter M5	Écrou moyen M5	Tuerca media M5	•	•	•	•		
45	✓		G1000A140	Trascinatore per tallone	Puller for bead	Mitnehmer für Wulst	Entraîneur pour talon	Jalador para talón	•	•	•	•		
46	✓		G800A114	Prolunga per pressore ruote RFT	RFT wheel pusher extension	Verlängerung für RFT-Radniederhalter	Rallonge pour presseur roues RFT	Alargador para prensador ruedas RFT	•	•	•	•		



**LISTA DEI COMPONENTI - LIST OF COMPONENTS - TEILELISTE  
LISTE DES PIÈCES DÉTACHÉES - LISTA DE PIEZAS**

**Tavola N°1C - Rev. 1**

#		D.R.	N	Descrizione	Description	Beschreibung	Description	Descripción	ROT.HF643.200884	ROT.HF643.201881	ROT.HF643.201133	ROT.HF643.200983		
---	--	------	---	-------------	-------------	--------------	-------------	-------------	------------------	------------------	------------------	------------------	--	--

47	✓		730026450	Carter superiore per telaio	Upper guard for frame	Oberes Gehäuse für Rahmen	Cartier supérieur pour châssis	Cárter superior para bastidor	•	•				

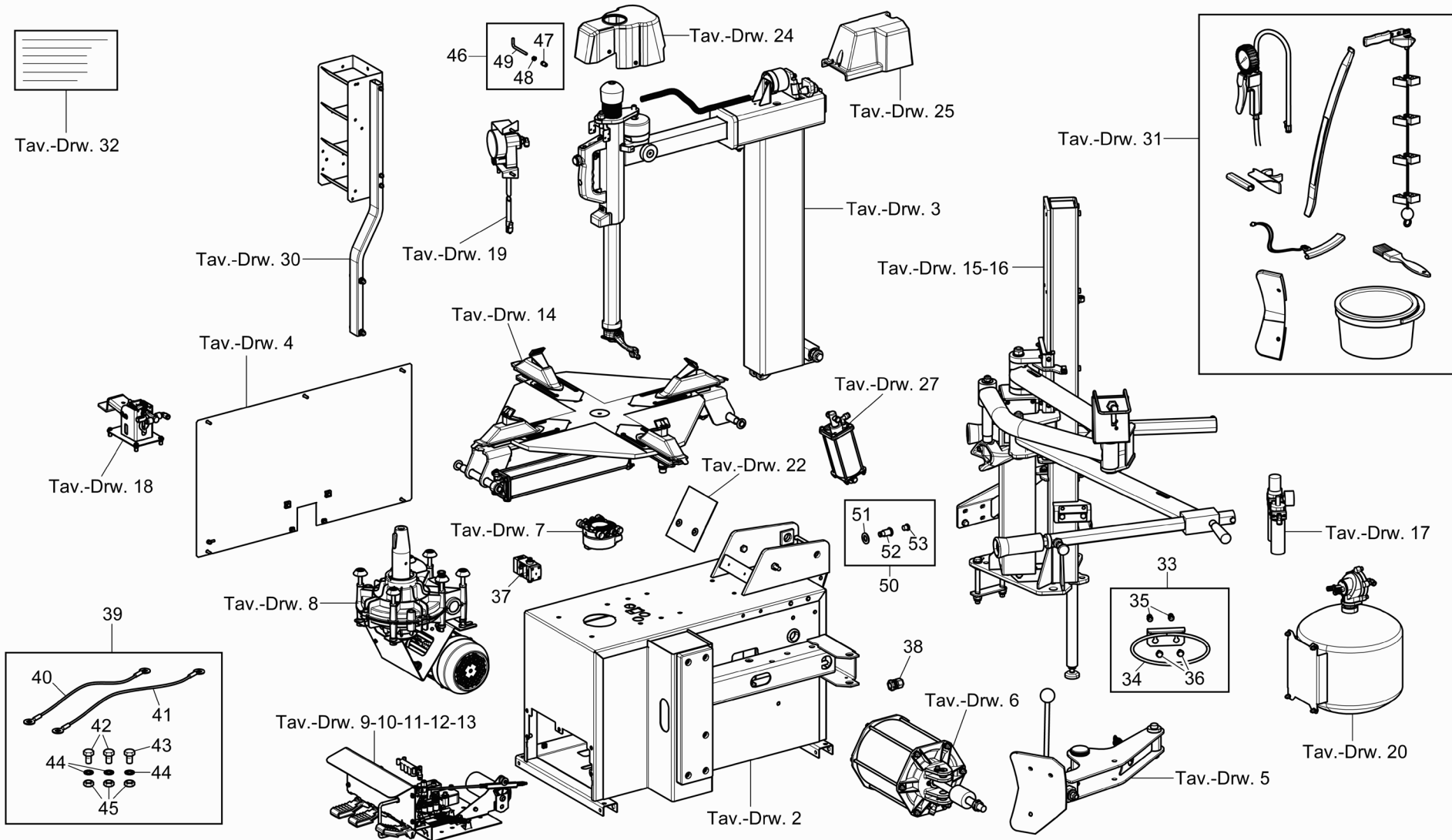

ROT. HP441.201102	ROT. HP641.200888	ROT. HP641.201034	ROT. HP641.200881	ROT. HP641.200785	ROT. HP641.201003	ROT. HP641.201788	ROT. HP641.201072	ROT. HP641.201065	ROT. HP641.201897	ROT. HP643.200894	ROT. HP643.201881	ROT. HP643.201133	ROT. HP643.200983	RAV. G7441.201140	RAV. G7441.200969	RAV. G7441.201119	RAV. G7441.200716	RAV. G7441.200877	RAV. G7441.200821	RAV. G7641.200945	RAV. G7641.200006	RAV. G7641.201041	RAV. G7641.200907	RAV. G7641.200983	RAV. G7641.201010	RAV. G7641.201089	RAV. G7641.200761	RAV. G7645.201232	RAV. G7645.200914	RAV. G7645.200890	RAV. G8645.201249	SPA. GA441.200976	SPA. GA441.201126	SPA. GA441.202000	SPA. GA641.201027	SPA. GA641.201096	SPA. GA641.200952	SPA. GA641.201058	SPA. GA645.200800				



LISTA DEI COMPONENTI - LIST OF COMPONENTS - TEILELISTE  
 LISTE DES PIECES DETACHEES - LISTA DE PIEZAS

Tavola N°1D - Rev. 1

ASSIEME GENERALE  
 MAIN ASSEMBLY  
 GENERALSATZ  
 ASSEMBLAGE GENERAL  
 JUNTO GENERAL



Pag. 22 di 235



LISTA DEI COMPONENTI - LIST OF COMPONENTS - TEILELISTE  
LISTE DES PIÈCES DÉTACHÉES - LISTA DE PIEZAS

Tavola N°1D - Rev. 1

ASSIEME GENERALE  
MAIN ASSEMBLY  
GENERSATZ  
ASSEMBLAGE GENERAL  
JUNTO GENERAL

Pag. 23 di 235

#		D.R	N	Descrizione	Description	Beschreibung	Description	Descripción	RAVG7441.201140	RAVG7441.200969	RAVG7441.201119	RAVG7441.200716	RAVG7441.200877	RAVG7441.200921	SPA.GA441.200976	SPA.GA441.201126	SPA.GA441.202000		
---	--	-----	---	-------------	-------------	--------------	-------------	-------------	-----------------	-----------------	-----------------	-----------------	-----------------	-----------------	------------------	------------------	------------------	--	--

2	✓	2A.1	730098460	Gruppo telaio	Frame assembly	Rahmensatz	Ensemble châssis	Conjunto bastidor	•	•	•	•	•	•	•	•	•		
3	✓	3A.0	730098120	Kit palo	Post kit	Stangenset	Kit poteau	Kit palo	•	•	•	•	•	•	•	•	•		
4	✓	4A.0	730094172	Gruppo cofano laterale	Lateral casing assembly	Seitlicher Haubesatz	Ensemble coffre latéral	Conjunto capot lateral			•	•	•	•	•	•	•		
	✓	4B.0	730094221	Gruppo cofano laterale	Lateral casing assembly	Seitlicher Haubesatz	Ensemble coffre latéral	Conjunto capot lateral	•	•					•				
5	✓	5A.0	730098470	Kit braccio stallonatore	Bead breaker arm kit	Abdrückerarmset	Kit bras décolle-pneus	Kit brazo destalonador	•	•	•	•	•	•	•	•	•		
6	✓	6A.0	730098480	Kit cilindro stallonatore	Bead breaker cylinder kit	Abdrückzylinderset	Kit cylindre décolle-pneus	Kit cilindro destalonador	•	•	•	•	•	•	•	•	•		
7	✓	7A.0	140390221	Insieme distributore rotante	Rotating distributor assembly	Rotationsverteilersatz	Ensemble distributeur rotatif	Conjunto distribuidor giratorio	•	•	•	•			•	•			
	✓	7B.0	140302093	Insieme distributore rotante	Rotating distributor assembly	Rotationsverteilersatz	Ensemble distributeur rotatif	Conjunto distribuidor giratorio						•			•		
8	✓	8A.1	730098290	Kit motoriduttore	Gearmotor kit	Untersetzerset	Kit motoréducteur	Kit motorreductor			•	•	•	•	•	•	•		
	✓	8D.1	730098590	Kit motoriduttore	Gearmotor kit	Untersetzerset	Kit motoréducteur	Kit motorreductor	•	•						•			
9	✓	9A.0	730098300	Kit pedaliera	Pedalboard kit	Pedalsteuerungset	Kit pédalier	Kit pedalera			•	•	•	•	•	•	•		
	✓	9D.0	730098600	Kit pedaliera	Pedalboard kit	Pedalsteuerungset	Kit pédalier	Kit pedalera	•	•						•			
10	✓	10.0	140990391	Insieme pedale stallonatore	Bead breaker pedal assembly	Abdrückpedalsatz	Ensemble pédale décolle-pneus	Conjunto pedal destalonador	•	•	•	•	•	•	•	•	•		
11	✓	11.0	140990401	Insieme pedale mandrino	Chuck pedal assembly	Spindelpedalsatz	Ensemble pédale mandrin	Conjunto pedal mandril	•	•	•	•	•	•	•	•	•		
12	✓	12.0	140990431	Gruppo pedale	Pedal assembly	Pedalsatz	Ensemble pédal	Conjunto pedal	•	•	•	•	•	•	•	•	•		
13	✓	13A.0	730098310	Pedale	Pedal	Pedal	Pédale	Pedal			•	•	•	•	•	•	•		
	✓	13C.0	730098640	Pedale rotazione mandrino	Chuck rotation pedal	Spindeldrehungspedal	Pédale de rotation mandrin	Pedal rotación mandril	•	•						•			
14	✓	14A.0	730094620	Montaggio mandrino quadro 10"-22"	10"-22" square chuck assembly	Montage der quadratischen Spindel 10"-22"	Montage mandrin carré 10"-22"	Montaje mandril cuadrado 10"-22"			•	•	•		•	•	•		
	✓	14D.0	730094630	Montaggio mandrino quadro 10"-22"	10"-22" square chuck assembly	Montage der quadratischen Spindel 10"-22"	Montage mandrin carré 10"-22"	Montaje mandril cuadrado 10"-22"						•			•		
	✓	14G.0	730093190	Montaggio mandrino quadro 10"-20"	10"-20" square chuck assembly	Montage der quadratischen Spindel 10"-20"	Montage mandrin carré 10"-20"	Montaje mandril cuadrado 10"-20"	•										
15	✓	15B.0	770791000	Premitalone pneumatico	Pneumatic bead press	Pneumatischer Wulstabdrücker	Pousse-talon pneumatique	Presionatalón neumático							•				
	✓	15D.0	PLUS73	Dispositivo premi-alza talone pneumatico	Pneumatic bead press/lift device	Pneumatische Wulstabdrück-Hubvorrichtung	Dispositif pousse-lève pneu	Dispositivo presiona-levantatalón neumático				•							
16	✓	16B.0	770790990	Premitalone	Bead press	Wulstabdrücker	Pousse-talon	Presionatalón							•				



LISTA DEI COMPONENTI - LIST OF COMPONENTS - TEILELISTE  
LISTE DES PIÈCES DÉTACHÉES - LISTA DE PIEZAS

Tavola N°1D - Rev. 1

ASSIEME GENERALE  
MAIN ASSEMBLY  
GENERSATZ  
ASSEMBLAGE GENERAL  
JUNTO GENERAL

Pag. 24 di 235

#		D.R	N	Descrizione	Description	Beschreibung	Description	Descripción	RAVG7441.201140	RAVG7441.200969	RAVG7441.201119	RAVG7441.200716	RAVG7441.200877	RAVG7441.200921	SPA.GA441.200976	SPA.GA441.201126	SPA.GA441.202000		
---	--	-----	---	-------------	-------------	--------------	-------------	-------------	-----------------	-----------------	-----------------	-----------------	-----------------	-----------------	------------------	------------------	------------------	--	--

17	✓	17A.1	730190010	Kit condizionamento aria	Air conditioning kit	Luft-Klimatisierungsset	Kit conditionnement air	Kit acondicionamiento aire	•	•	•	•	•	•	•	•	•		
	✓	17B.1	730190020	Kit condizionamento aria	Air conditioning kit	Luft-Klimatisierungssetb	Kit conditionnement air	Kit acondicionamiento aire							•				
18	✓	18A.1	730097650	Pedale di gonfiaggio	Inflation pedal	Aufpumpedal	Pédale de gonflage	Pedal de inflado			•	•			•				
	✓	18B.0	730097770	Kit pedale di gonfiaggio	Inflation pedal kit	Aufpumpedalset	Kit pédale de gonflage	Kit pedal de inflado					•				•		
19	✓	19.0	730097660	Kit manometro di gonfiaggio	Inflation pressure gauge kit	Luftdruckmesser-Set	Kit manomètre de gonflage	Kit manómetro de inflado			•	•	•	•	•	•	•		
20	✓	20.0	730097780	Kit serbatoio	Tank kit	Tankset	Kit réservoir	Kit tanque					•				•		
22	✓	22A.0	140390580	Gruppo protezione base palo	Post base protection assembly	Stangenboden-Schutzsatz	Ensemble protection em-base poteau	Conjunto protección base palo	•	•	•	•	•	•	•	•	•		
24	✓	24D.0	730097820	Copertura braccio	Arm cover	Armabdeckung	Couverture bras	Cobertura brazo	•	•	•	•	•	•	•	•	•		
25	✓	25C.0	730098210	Copertura palo	Post cover	Stangenabdeckung	Couverture poteau	Cobertura palo	•	•	•	•	•	•	•	•	•		
27	✓	27A.0	730091270	Gruppo pistone ribaltamento palo	Tilting post piston assembly	Stangeneinheitsskipung-Kolbensatz	Ensemble piston bascule-poteau	Conjunto pistón vuelco palo	•	•	•	•	•	•	•	•	•		
30	✓	30.0	770090410	Portaoggetti	Tool box	Objektträger	Porte-objets	Porta-objetos				•		•					
31	✓	31A.0	730097900	Kit dotazione	Equipment kit	Ausstattungsset	Kit dotation	Kit dotación				•		•		•	•		
	✓	31D.0	730097850	Kit dotazione	Equipment kit	Ausstattungsset	Kit dotation	Kit dotación							•				
	✓	31E.0	730099090	Kit dotazione	Equipment kit	Ausstattungsset	Kit dotation	Kit dotación	•	•						•			
	✓	31H.0	730099950	Kit dotazione	Equipment kit	Ausstattungsset	Kit dotation	Kit dotación				•							
32		32D.0	-	Posizionamento targhette	Nameplates positioning	Schilderpositionierung	Positionnement plaquettes	Posicionamiento plaquitas	•	•	•	•	•	•	•	•	•		
33	✓		730095750	Gruppo anello portagrasso	Grease holder ring assembly	Fetthaltersatz	Ensemble anneau porte-graisse	Conjunto anillo soporte grasa	•	•	•	•	•		•	•	•		
	✓		730097640	Kit portagrasso	Grease holder kit	Fetthalterset	Kit porte-graisse	Kit soporte grasa							•				
34	✓		730026380	Anello portagrasso	Grease-holder ring	Fettring	Anneau porte-graisse	Anillo soporte grasa	•	•	•	•	•		•	•	•		
	✓		B0223000	Anello contenitore grasso	Grease holder ring	Fettführungsring	Anneau cuve porte-graisse	Anillo porta grasa							•				
35	✓		251107	Inserto filettato M6	M6 threaded insert	Gewindeinsatz M6	Renfort fileté M6	Inserto roscado M6	•	•	•	•	•		•	•	•		
36	✓		271021	TBEI M6x20	TBEI M6x20 bolt	Schraube TBEI M6x20	Vis TBEI M6x20	Tornillo TBEI M6x20	•	•	•	•	•		•	•	•		
	✓		272172	TE M8x16	TE M8x16 bolt	Schraube TE M8x16	Vis TE M8x16	Tornillo TE M8x16							•				
37	✓		710590670	Gruppo valvola di gonfiaggio 60 PSI	60 PSI inflation valve assembly	Aufpumpventilsatz 60 PSI	Ensemble soupape de gonflage 60 PSI	Conjunto válvula de inflado 60 PSI	•	•	•	•	•	•	•	•	•		



LISTA DEI COMPONENTI - LIST OF COMPONENTS - TEILELISTE  
LISTE DES PIÈCES DÉTACHÉES - LISTA DE PIEZAS

Tavola N°1D - Rev. 1

ASSIEME GENERALE  
MAIN ASSEMBLY  
GENERALSATZ  
ASSEMBLAGE GENERAL  
JUNTO GENERAL

Pag. 25 di 235

#		D.R.	N	Descrizione	Description	Beschreibung	Description	Descripción	RAVG7441.201140	RAVG7441.200969	RAVG7441.201119	RAVG7441.200716	RAVG7441.200877	RAVG7441.200921	SPA.GA441.200976	SPA.GA441.201126	SPA.GA441.202000		
---	--	------	---	-------------	-------------	--------------	-------------	-------------	-----------------	-----------------	-----------------	-----------------	-----------------	-----------------	------------------	------------------	------------------	--	--

38	✓		599074	Pressacavo	Cable press	Kabeldurchführung	Presse-câble	Prensaestopas	•	•	•	•	•	•	•	•	•		
39	✓		730098500	Kit messa a terra	Grounding kit	Erdungsset	Kit mise à la terre	Kit puesta a tierra	•	•	•	•	•	•	•	•	•		
40	✓		790065110	Cavo di terra	Ground cable	Erdkabel	Câble de masse	Cable tierra	•	•	•	•	•	•	•	•	•		
41	✓		790065160	Cavo di terra	Ground cable	Erdkabel	Câble de masse	Cable tierra	•	•	•	•	•	•	•	•	•		
42	✓		203208	TE M5x20	TE M5x20 bolt	Schraube TE M5x20	Vis TE M5x20	Tornillo TE M5x20	•	•	•	•	•	•	•	•	•		
43	✓		203124	TE M5x30	TE M5x30 bolt	Schraube TE M5x30	Vis TE M5x30	Tornillo TE M5x30	•	•	•	•	•	•	•	•	•		
44	✓		239017	Rosetta	Washer	Unterlegscheibe	Rondelle	Arandela	•	•	•	•	•	•	•	•	•		
45	✓		224005	Dado medio M5	M5 med nut	Mittlere Mutter M5	Écrou moyen M5	Tuerca media M5	•	•	•	•	•	•	•	•	•		
46	✓		730098340	Kit gancio pistola di gonfiaggio	Inflation gun coupler kit	Aufpumpepistole-Kupplungsset	Kit crochet pistolet de gonflage	Kit engancho pistola de inflado	•	•					•				
47	✓		251102	Inserto filettato	Threaded insert	Gewindeinsatz	Renfort fileté	Inserto roscado	•	•					•				
48	✓		224007	Dado medio M6	M6 med nut	Mittlere Mutter M6	Écrou moyen M6	Tuerca media M6	•	•					•				
49	✓		140330740	Supporto pistola	Gun support	Pistolenträger	Support pistolet	Soporte pistola	•	•					•				
50	✓		730098350	Kit raccordo pistola di gonfiaggio	Inflation gun fitting kit	Aufpumpepistole-Anschluss	Kit raccord pistolet de gonflage	Kit empalme pistola de inflado	•	•					•				
51	✓		236020	Rondella piana 17	17 flat washer	Ebene Unterlagsscheibe 17	Rondelle plane 17	Arandela plana 17	•	•					•				
52	✓		325093	Raccordo passalamiera	Pass-through fitting	Durchgangsanschluss	Raccord passe-tôle	Empalme pasachapa	•	•					•				
53	✓		311012	Tappo esagonale	Hexagonal plug	Sechseckiger Stöpsel	Bouchon hexagonal	Tapón hexagonal	•	•					•				

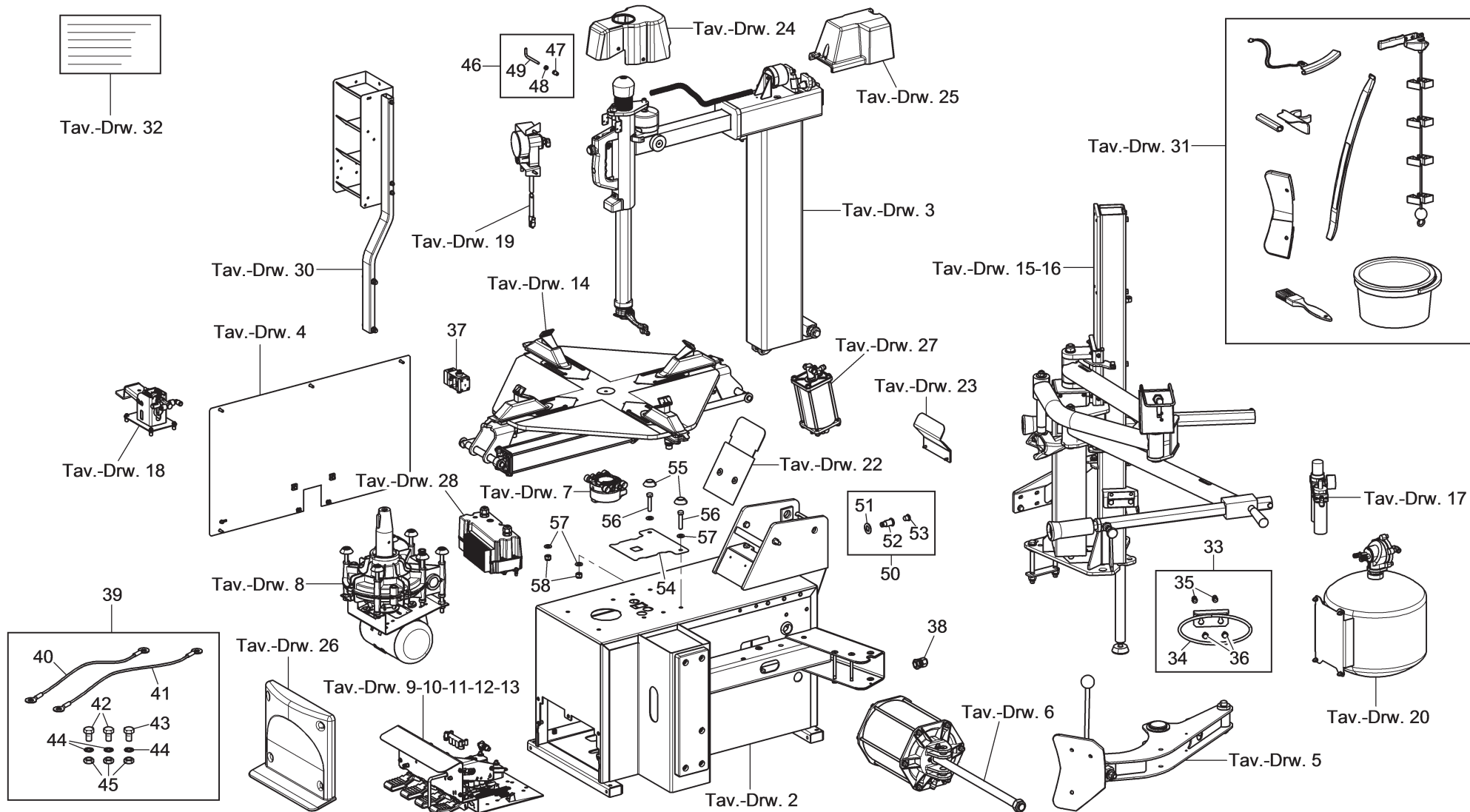

ROT. HP441.201102	ROT. HP641.200888	ROT. HP641.201034	ROT. HP641.200891	ROT. HP641.200785	ROT. HP641.201003	ROT. HP641.201788	ROT. HP641.201072	ROT. HP641.201065	ROT. HP641.201897	ROT. HP643.200894	ROT. HP643.201881	ROT. HP643.201133	ROT. HP643.200983	RAV. G7441.201140	RAV. G7441.200969	RAV. G7441.201119	RAV. G7441.200716	RAV. G7441.200877	RAV. G7441.200821	RAV. G7641.200945	RAV. G7641.200006	RAV. G7641.201041	RAV. G7641.200907	RAV. G7641.200683	RAV. G7641.201010	RAV. G7641.201089	RAV. G7641.200761	RAV. G7645.201232	RAV. G7645.200914	RAV. G7645.200990	RAV. G8645.201249	SPA. GA441.200976	SPA. GA441.201126	SPA. GA441.202000	SPA. GA641.201027	SPA. GA641.201096	SPA. GA641.200952	SPA. GA641.201058	SPA. GA645.200600		
																					•	•	•	•	•	•	•										•	•	•	•	



LISTA DEI COMPONENTI - LIST OF COMPONENTS - TEILELISTE  
LISTE DES PIECES DETACHEES - LISTA DE PIEZAS

Tavola N°1E - Rev. 1

ASSIEME GENERALE  
MAIN ASSEMBLY  
GENERSATZ  
ASSEMBLAGE GENERAL  
JUNTO GENERAL



LISTA DEI COMPONENTI - LIST OF COMPONENTS - TEILELISTE  
LISTE DES PIÈCES DÉTACHÉES - LISTA DE PIEZAS

Tavola N°1E - Rev. 1

ASSIEME GENERALE  
MAIN ASSEMBLY  
GENERSATZ  
ASSEMBLAGE GENERAL  
JUNTO GENERAL

Pag. 27 di 235

#		D.R	N	Descrizione	Description	Beschreibung	Description	Descripción	RAV.G7641.200945	RAV.G7641.200006	RAV.G7641.201041	RAV.G7641.200907	RAV.G7641.200693	RAV.G7641.201010	RAV.G7641.201089	RAV.G7641.200761	SPA.GA641.201027	SPA.GA641.201096	SPA.GA641.200952	SPA.GA641.201058		
---	--	-----	---	-------------	-------------	--------------	-------------	-------------	------------------	------------------	------------------	------------------	------------------	------------------	------------------	------------------	------------------	------------------	------------------	------------------	--	--

2	✓	2B.0	730098100	Gruppo telaio	Frame assembly	Rahmensatz	Ensemble châssis	Conjunto bastidor	•	•	•	•	•	•	•	•	•	•	•	•		
3	✓	3A.0	730098120	Kit palo	Post kit	Stangenset	Kit poteau	Kit palo	•	•	•	•	•	•	•	•	•	•	•	•		
4	✓	4A.0	730094172	Gruppo cofano laterale	Lateral casing assembly	Seitlicher Haubesatz	Ensemble coffre latéral	Conjunto capot lateral	•	•	•	•	•	•	•	•	•	•	•	•		
	✓	4B.0	730094221	Gruppo cofano laterale	Lateral casing assembly	Seitlicher Haubesatz	Ensemble coffre latéral	Conjunto capot lateral									•					
5	✓	5B.0	730097740	Kit braccio stallonatore	Bead breaker arm kit	Abdrückerarmset	Kit bras décolle-pneus	Kit brazo destalonador	•	•	•	•	•	•	•	•	•	•	•	•		
6	✓	6B.1	730098150	Kit cilindro stallonatore	Bead breaker cylinder kit	Abdrückzylinderset	Kit cylindre décolle-pneus	Kit cilindro destalonador	•	•	•	•	•	•	•	•	•	•	•	•		
7	✓	7A.0	140390221	Insieme distributore rotante	Rotating distributor assembly	Rotationsverteilersatz	Ensemble distributeur rotatif	Conjunto distribuidor giratorio	•	•		•	•	•		•			•			
	✓	7B.0	140302093	Insieme distributore rotante	Rotating distributor assembly	Rotationsverteilersatz	Ensemble distributeur rotatif	Conjunto distribuidor giratorio				•			•					•		
8	✓	8A.1	730098290	Kit motoriduttore	Gearmotor kit	Untersetzerset	Kit motoréducteur	Kit motorreductor					•	•	•				•			
	✓	8B.0	730098140	Kit motoriduttore	Gearmotor kit	Untersetzerset	Kit motoréducteur	Kit motorreductor	•	•	•	•					•			•	•	
9	✓	9A.0	730098300	Kit pedaliera	Pedalboard kit	Pedalsteuerungset	Kit pédalier	Kit pedalera					•	•	•							
	✓	9B.0	730098160	Kit pedaliera	Pedalboard kit	Pedalsteuerungset	Kit pédalier	Kit pedalera	•	•	•	•					•			•	•	
10	✓	10.0	140990391	Insieme pedale stallonatore	Bead breaker pedal assembly	Abdrückpedalsatz	Ensemble pédale décolle-pneus	Conjunto pedal destalonador	•	•	•	•	•	•	•	•	•	•	•	•		
11	✓	11.0	140990401	Insieme pedale mandrino	Chuck pedal assembly	Spindelpedalsatz	Ensemble pédale mandrin	Conjunto pedal mandril	•	•	•	•	•	•	•	•	•	•	•	•		
12	✓	12.0	140990431	Gruppo pedale	Pedal assembly	Pedalsatz	Ensemble pédal	Conjunto pedal	•	•	•	•	•	•	•	•	•	•	•	•		
13	✓	13A.0	730098310	Pedale	Pedal	Pedal	Pédale	Pedal					•	•	•							
	✓	13B.0	730096820	Gruppo pedale con inverter	Pedal assembly with inverter	Pedalsatz mit Frequenzumformer	Ensemble pédale avec inverseur	Conjunto pedal con inversor	•	•	•	•					•			•	•	
14	✓	14A.0	730094620	Montaggio mandrino quadro 10"-22"	10"-22" square chuck assembly	Montage der quadratischen Spindel 10"-22"	Montage mandrin carré 10"-22"	Montaje mandril cuadrado 10"-22"							•		•					
	✓	14B.1	730095501	Mandrino quadro 10"-24"	10"-24" square chuck	Quadratische Spindel 10"-24"	Mandrin carré 10"-24"	Mandril cuadrado 10"-24"	•	•		•	•							•		
	✓	14C.0	730095491	Montaggio mandrino 10"-24"	10"-24" chuck assembly	Montage der Spindel 10"-24"	Montage mandrin 10"-24"	Montaje mandril 10"-24"				•									•	
	✓	14D.0	730094630	Montaggio mandrino quadro 10"-22"	10"-22" square chuck assembly	Montage der quadratischen Spindel 10"-22"	Montage mandrin carré 10"-22"	Montaje mandril cuadrado 10"-22"								•				•		
15	✓	15B.0	770791000	Premitallo pneumatico	Pneumatic bead press	Pneumatischer Wulstabdrucker	Pousse-talon pneumatique	Presionatalón neumático				•	•									



LISTA DEI COMPONENTI - LIST OF COMPONENTS - TEILELISTE  
LISTE DES PIÈCES DÉTACHÉES - LISTA DE PIEZAS

Tavola N°1E - Rev. 1

ASSIEME GENERALE  
MAIN ASSEMBLY  
GENERSATZ  
ASSEMBLAGE GENERAL  
JUNTO GENERAL

Pag. 28 di 235

#		D.R	N	Descrizione	Description	Beschreibung	Description	Descripción	RAY.G7641.200945	RAY.G7641.200006	RAY.G7641.201041	RAY.G7641.200907	RAY.G7641.200693	RAY.G7641.201010	RAY.G7641.201089	RAY.G7641.200761	SPA.GA641.201027	SPA.GA641.201096	SPA.GA641.200952	SPA.GA641.201058		
																					→	→

15	✓	15C.0	770791020	Premitallo pneumatico	Pneumatic bead press	Pneumatischer Wulstabdrücker	Pousse-talon pneumatique	Presionatalón neumático																	
16	✓	16B.0	770790990	Premitallo	Bead press	Wulstabdrücker	Pousse-talon	Presionatalón				•	•												
	✓	16C.0	770791010	Premitallo	Bead press	Wulstabdrücker	Pousse-talon	Presionatalón																	
17	✓	17A.1	730190010	Kit condizionamento aria	Air conditioning kit	Luft-Klimatisierungsset	Kit conditionnement air	Kit acondicionamiento aire	•	•	•				•	•									
	✓	17B.1	730190020	Kit condizionamento aria	Air conditioning kit	Luft-Klimatisierungsset	Kit conditionnement air	Kit acondicionamiento aire				•	•		•										
18	✓	18A.1	730097650	Pedale di gonfiaggio	Inflation pedal	Aufpump pedal	Pédale de gonflage	Pedal de inflado	•	•		•	•	•											
	✓	18B.0	730097770	Kit pedale di gonfiaggio	Inflation pedal kit	Aufpump pedalset	Kit pédale de gonflage	Kit pedal de inflado				•			•										
19	✓	19.0	730097660	Kit manometro di gonfiaggio	Inflation pressure gauge kit	Luftdruckmesser-Set	Kit manomètre de gonflage	Kit manómetro de inflado	•	•	•	•	•	•	•	•	•	•	•	•	•	•	•	•	•
20	✓	20.0	730097780	Kit serbatoio	Tank kit	Tankset	Kit réservoir	Kit tanque				•			•										
22	✓	22B.0	730098200	Copertura palo	Post cover	Stangenabdeckung	Couverture poteau	Cobertura palo	•	•	•	•	•	•	•	•	•	•	•	•	•	•	•	•	•
23	✓	23B.0	730099860	Kit copertura base palo	Post base cover kit	Stangenbodenabdeckungsset	Kit couverture embase poteau	Kit cobertura base palo	•	•	•	•	•	•	•	•	•	•	•	•	•	•	•	•	•
24	✓	24D.0	730097820	Copertura braccio	Arm cover	Armaddeckung	Couverture bras	Cobertura brazo	•	•	•	•	•	•	•	•	•	•	•	•	•	•	•	•	•
25	✓	25C.0	730098210	Copertura palo	Post cover	Stangenabdeckung	Couverture poteau	Cobertura palo	•	•	•	•	•	•	•	•	•	•	•	•	•	•	•	•	•
26	✓	26A.0	730098110	Carter frontale	Front guard	Vorderes Gehäuse	Carter frontal	Cárter anterior																	
27	✓	27B.0	730092590	Gruppo cilindro ribaltamento	Tilting cylinder assembly	Zylinderskippsatz	Ensemble cylindre basculage	Conjunto cilindro vuelco	•	•	•	•	•	•	•	•	•	•	•	•	•	•	•	•	•
28	✓	28.1	730096861	Gruppo inverter	Inverter assembly	Frequenzumformersatz	Ensemble inverseur	Conjunto inversor	•	•	•	•				•									
30	✓	30.0	770090410	Portaoggetti	Tool box	Objekträger	Porte-objets	Porta-objetos					•	•											
31	✓	31A.0	730097900	Kit dotazione	Equipment kit	Ausstattungsset	Kit dotation	Kit dotación	•	•	•				•	•									
	✓	31D.0	730097850	Kit dotazione	Equipment kit	Ausstattungsset	Kit dotation	Kit dotación				•	•												
	✓	31F0	730098390	Kit dotazione	Equipment kit	Ausstattungsset	Kit dotation	Kit dotación																	
32		32E.2	-	Posizionamento targhette	Nameplates positioning	Schilderpositionierung	Positionnement plaquettes	Posicionamiento plaquetas	•	•	•	•	•	•	•	•	•	•	•	•	•	•	•	•	•
33	✓		730095750	Gruppo anello porta-grasso	Grease holder ring assembly	Fetthaltersatz	Ensemble anneau porte-graisse	Conjunto anillo soporte grasa	•	•	•				•	•									
	✓		730097640	Kit portagrasso	Grease holder kit	Fetthalterset	Kit porte-graisse	Kit soporte grasa				•	•			•									



LISTA DEI COMPONENTI - LIST OF COMPONENTS - TEILELISTE  
LISTE DES PIÈCES DÉTACHÉES - LISTA DE PIEZAS

Tavola N°1E - Rev. 1

ASSIEME GENERALE  
MAIN ASSEMBLY  
GENERSATZ  
ASSEMBLAGE GENERAL  
JUNTO GENERAL

Pag. 29 di 235

#		D.R	N	Descrizione	Description	Beschreibung	Description	Descripción	RAY.G7641.200945	RAY.G7641.200006	RAY.G7641.201041	RAY.G7641.200907	RAY.G7641.200893	RAY.G7641.201010	RAY.G7641.201089	RAY.G7641.200761	SPA.GA641.201027	SPA.GA641.201096	SPA.GA641.200952	SPA.GA641.201058		
---	--	-----	---	-------------	-------------	--------------	-------------	-------------	------------------	------------------	------------------	------------------	------------------	------------------	------------------	------------------	------------------	------------------	------------------	------------------	--	--

34	✓		730026380	Anello portagrasso	Grease-holder ring	Fettring	Anneau porte-graisse	Anillo soporte grasa	•	•	•			•	•								
	✓		B0223000	Anello contenitore grasso	Grease holder ring	Fettführungsring	Anneau cuve porte-graisse	Anillo porta grasa					•	•		•							
35	✓		251107	Inserto filettato M6	M6 threaded insert	Gewindeinsatz M6	Renfort fileté M6	Inserto roscado M6	•	•	•			•	•								
36	✓		271021	TBEI M6x20	TBEI M6x20 bolt	Schraube TBEI M6x20	Vis TBEI M6x20	Tornillo TBEI M6x20	•	•	•			•	•								
	✓		272172	TE M8x16	TE M8x16 bolt	Schraube TE M8x16	Vis TE M8x16	Tornillo TE M8x16				•	•			•							
37	✓		710590670	Gruppo valvola di gonfiaggio 60 PSI	60 PSI inflation valve assembly	Aufpumpventilsatz 60 PSI	Ensemble soupape de gonflage 60 PSI	Conjunto válvula de inflado 60 PSI	•	•	•	•	•	•	•	•	•	•	•	•	•		
38	✓		599074	Pressacavo	Cable press	Kabeldurchführung	Presse-câble	Prensaestopas	•	•			•										
39	✓		730098180	Kit messa a terra	Grounding kit	Erdungsset	Kit mise à la terre	Kit puesta a tierra	•	•	•	•	•			•					•	•	
	✓		730098330	Kit messa a terra	Grounding kit	Erdungsset	Kit mise à la terre	Kit puesta a tierra							•	•							
40	✓		790065110	Cavo di terra	Ground cable	Erdkabel	Câble de masse	Cable tierra	•	•	•	•	•	•	•	•	•	•	•	•	•		
41	✓		790065160	Cavo di terra	Ground cable	Erdkabel	Câble de masse	Cable tierra	•	•	•	•	•	•	•	•	•	•	•	•	•		
42	✓		203208	TE M5x20	TE M5x20 bolt	Schraube TE M5x20	Vis TE M5x20	Tornillo TE M5x20	•	•	•	•	•	•	•	•	•	•	•	•	•		
43	✓		203124	TE M5x30	TE M5x30 bolt	Schraube TE M5x30	Vis TE M5x30	Tornillo TE M5x30	•	•	•	•	•	•	•	•	•	•	•	•	•		
44	✓		239017	Rosetta	Washer	Unterlegscheibe	Rondelle	Arandela	•	•	•	•	•	•	•	•	•	•	•	•	•		
45	✓		224005	Dado medio M5	M5 med nut	Mittlere Mutter M5	Écrou moyen M5	Tuerca media M5	•	•	•	•	•	•	•	•	•	•	•	•	•		
46	✓		730098340	Kit gancio pistola di gonfiaggio	Inflation gun coupler kit	Aufpumpepistole-Kupplungsset	Kit crochet pistolet de gonflage	Kit enganche pistola de inflado								•							
47	✓		251102	Inserto filettato	Threaded insert	Gewindeinsatz	Renfort fileté	Inserto roscado								•							
48	✓		224007	Dado medio M6	M6 med nut	Mittlere Mutter M6	Écrou moyen M6	Tuerca media M6								•							
49	✓		140330740	Supporto pistola	Gun support	Pistolenträger	Support pistolet	Soporte pistola								•							
50	✓		730098350	Kit raccordo pistola di gonfiaggio	Inflation gun fitting kit	Aufpumpepistole-Anschlussset	Kit raccord pistolet de gonflage	Kit empalme pistola de inflado								•							
51	✓		236020	Rondella piana 17	17 flat washer	Ebene Unterlagsscheibe 17	Rondelle plane 17	Arandela plana 17								•							
52	✓		325093	Raccordo passalamiera	Pass-through fitting	Durchgangsanschluss	Raccord passe-tôle	Empalme pasachapa								•							
53	✓		311012	Tappo esagonale	Hexagonal plug	Sechseckiger Stöpsel	Bouchon hexagonal	Tapón hexagonal								•							
54	✓		730026450	Carter superiore per telaio	Upper guard for frame	Oberes Gehäuse für Rahmen	Carter supérieur pour châssis	Cárter superior para bastidor				•	•										



**LISTA DEI COMPONENTI - LIST OF COMPONENTS - TEILELISTE  
LISTE DES PIÈCES DÉTACHÉES - LISTA DE PIEZAS**

**Tavola N°1E - Rev. 1**

ASSIEME GENERALE  
MAIN ASSEMBLY  
GENERSATZ  
ASSEMBLAGE GENERAL  
JUNTO GENERAL

**Pag. 30 di 235**

#		D.R	N	Descrizione	Description	Beschreibung	Description	Descripción	RAV.G7641.200945	RAV.G7641.200006	RAV.G7641.201041	RAV.G7641.200907	RAV.G7641.200693	RAV.G7641.201010	RAV.G7641.201089	RAV.G7641.200761	SPA.GA641.201027	SPA.GA641.201096	SPA.GA641.200952	SPA.GA641.201058		
---	--	-----	---	-------------	-------------	--------------	-------------	-------------	------------------	------------------	------------------	------------------	------------------	------------------	------------------	------------------	------------------	------------------	------------------	------------------	--	--

55	✓		730015400	Tappo protezione	Protection plug	Schutzstößel	Bouchon protection	Tapón protección															
56	✓		203066	TE M10x50	Bolt TE M10x50	Schraube TE M10x50	Vis TE M10x50	Tornillo TE M10x50															
57	✓		236007	Rondella piana 10,5x21x2	Flat washer 10.5x21x2	Ebene Unterlagsschei- be 10,5x21x2	Rondelle Fe 10,5x21x2	Arandela Fe 10,5x21x2															
58	✓		228012	Dado autobloccante M10	Self-locking nut M10	Selbstsichernde Mutter M10	Écrou auto-bloquant M10	Tuerca autoblocante M10															





LISTA DEI COMPONENTI - LIST OF COMPONENTS - TEILELISTE  
LISTE DES PIÈCES DÉTACHÉES - LISTA DE PIEZAS

Tavola N°1F - Rev. 1

ASSIEME GENERALE  
MAIN ASSEMBLY  
GENERSATZ  
ASSEMBLAGE GENERAL  
JUNTO GENERAL

Pag. 32 di 235

#		D.R	N	Descrizione	Description	Beschreibung	Description	Descripción	RAVG7645.201232	RAVG7645.200914	RAVG7645.200990	RAVG8645.201249	SPA_GA645.200600		

2	✓	2C.1	730099670	Kit basamento con inserti	Base kit with inserts	Grundplattenset mit Einsätze	Kit bâti avec renforts	Kit base con insertos	•	•	•	•	•		
3	✓	3C.0	730097720	Kit palo	Post kit	Stangenset	Kit poteau	Kit palo	•	•	•	•	•		
	✓	3E.0	730098990	Kit palo	Post kit	Stangenset	Kit poteau	Kit palo				•			
4	✓	4A.0	730094172	Gruppo cofano laterale	Lateral casing assembly	Seitlicher Haubesatz	Ensemble coffre latéral	Conjunto capot lateral	•	•	•	•	•		
5	✓	5B.0	730097740	Kit braccio stallonatore	Bead breaker arm kit	Abdrückerarmset	Kit bras décolle-pneus	Kit brazo destalonador	•	•			•		
	✓	5C.0	730097600	Kit braccio stallonatore	Bead breaker arm kit	Abdrückerarmset	Kit bras décolle-pneus	Kit brazo destalonador			•	•			
6	✓	6C.0	730097610	Kit cilindro stallonatore	Bead breaker cylinder kit	Abdrückzylinderset	Kit cylindre décolle-pneus	Kit cilindro destalonador	•	•	•	•	•		
7	✓	7A.0	140390221	Insieme distributore rotante	Rotating distributor assembly	Rotationsverteilersatz	Ensemble distributeur rotatif	Conjunto distribuidor giratorio	•		•		•		
	✓	7B.0	140302093	Insieme distributore rotante	Rotating distributor assembly	Rotationsverteilersatz	Ensemble distributeur rotatif	Conjunto distribuidor giratorio				•		•	
8	✓	8C.0	730097570	Kit motoriduttore inverter	Inverter gearmotor kit	Frequenzumformer-Untersetzer	Kit motoréducteur inverseur	Kit motorreductor inversor	•	•	•	•	•		
9	✓	9C.0	730097620	Kit pedaliera	Pedalboard kit	Pedalsteuerungset	Kit pédalier	Kit pedalera	•	•	•	•	•		
10	✓	10.0	140990391	Insieme pedale stallonatore	Bead breaker pedal assembly	Abdrückpedalsatz	Ensemble pédale décolle-pneus	Conjunto pedal destalonador	•	•	•	•	•		
11	✓	11.0	140990401	Insieme pedale mandrino	Chuck pedal assembly	Spindelpedalsatz	Ensemble pédale mandrin	Conjunto pedal mandril	•	•	•	•	•		
12	✓	12.0	140990431	Gruppo pedale	Pedal assembly	Pedalsatz	Ensemble pédal	Conjunto pedal	•	•	•	•	•		
13	✓	13B.0	730096820	Gruppo pedale con inverter	Pedal assembly with inverter	Pedalsatz mit Frequenzumformer	Ensemble pédale avec inverseur	Conjunto pedal con inversor	•	•	•	•	•		
14	✓	14E.0	730094811	Montaggio mandrino 10"-26"	10"-26" chuck assembly	Montage der Spindel 10"-26"	Montage mandrin 10"-26"	Montaje mandril 10"-26"	•		•		•		
	✓	14F.0	730094801	Montaggio mandrino 10"-26"	10"-26" chuck assembly	Montage der Spindel 10"-26"	Montage mandrin 10"-26"	Montaje mandril 10"-26"			•		•		
15	✓	15B.0	770791000	Premitalлоне pneumatico	Pneumatic bead press	Pneumatischer Wulstabdrücker	Pousse-talon pneumatique	Presionatalón neumático			•	•			
16	✓	16B.0	770790990	Premitalлоне	Bead press	Wulstabdrücker	Pousse-talon	Presionatalón			•	•			
17	✓	17B.1	730190020	Kit condizionamento aria	Air conditioning kit	Luft-Klimatisierungssetb	Kit conditionnement air	Kit acondicionamiento aire			•	•			
	✓	17C.1	730190030	Kit condizionamento aria	Air conditioning kit	Luft-Klimatisierungsset	Kit conditionnement air	Kit acondicionamiento aire	•	•			•		
18	✓	18A.1	730097650	Pedale di gonfiaggio	Inflation pedal	Aufpump pedal	Pédale de gonflage	Pedal de inflado	•		•		•		
	✓	18B.0	730097770	Kit pedale di gonfiaggio	Inflation pedal kit	Aufpump pedasset	Kit pédale de gonflage	Kit pedal de inflado			•		•		
19	✓	19.0	730097660	Kit manometro di gonfiaggio	Inflation pressure gauge kit	Luftdruckmesser-Set	Kit manomètre de gonflage	Kit manómetro de inflado	•	•	•	•	•		



LISTA DEI COMPONENTI - LIST OF COMPONENTS - TEILELISTE  
LISTE DES PIÈCES DÉTACHÉES - LISTA DE PIEZAS

Tavola N°1F - Rev. 1

ASSIEME GENERALE  
MAIN ASSEMBLY  
GENERSATZ  
ASSEMBLAGE GENERAL  
JUNTO GENERAL

Pag. 33 di 235

#	D.R.	N	Descrizione	Description	Beschreibung	Description	Descripción						T	T
								RAVG7645.201232	RAVG7645.200914	RAVG7645.200990	RAVG8645.201249	SPA_GA645.200600		



20	✓	20.0	730097780	Kit serbatoio	Tank kit	Tankset	Kit réservoir	Kit tanque		•							
21	✓	21B.0	730097520	Copertura base palo	Post base cover	Stangenbodenabdeckung	Couverture embase poteau	Cobertura base palo	•	•	•	•	•				
23	✓	23A.0	730097530	Copertura base palo	Post base cover	Stangenbodenabdeckung	Couverture embase poteau	Cobertura base palo	•	•	•	•	•				
24	✓	24D.0	730097820	Copertura braccio	Arm cover	Armaddeckung	Couverture bras	Cobertura brazo	•	•	•		•				
25	✓	25D.0	730097830	Copertura palo	Post cover	Stangenabdeckung	Couverture poteau	Cobertura palo	•	•	•	•	•				
27	✓	27B.0	730092590	Gruppo cilindro ribaltamento	Tilting cylinder assembly	Zylinderskippsatz	Ensemble cylindre basculage	Conjunto cilindro vuelco	•	•	•	•	•				
28	✓	28.1	730096861	Gruppo inverter	Inverter assembly	Frequenzumformersatz	Ensemble inverseur	Conjunto inversor	•	•	•	•	•				
29	✓	29.0	770090370	Gruppo limitatore di corsa	Stroke limiting device assembly	Hubbegrenzersatz	Ensemble limiteur de course	Conjunto limitador de carrera				•					
30	✓	30.0	770090410	Portaoggetti	Tool box	Objektträger	Porte-objets	Porta-objetos				•	•				
31	✓	31A.0	730097900	Kit dotazione	Equipment kit	Ausstattungsset	Kit dotation	Kit dotación	•	•			•				
	✓	31D.0	730097850	Kit dotazione	Equipment kit	Ausstattungsset	Kit dotation	Kit dotación				•					
	✓	31G.0	730098980	Kit dotazione	Equipment kit	Ausstattungsset	Kit dotation	Kit dotación					•				
32		32F.1	-	Posizionamento targhette	Nameplates positioning	Schilderpositionierung	Positionnement plaquettes	Posicionamiento plaquitas	•	•	•	•	•				
33	✓		730097880	Kit portagrasso	Grease holder kit	Fetthaltersset	Kit porte-graisse	Kit soporte grasa	•	•			•				
	✓		730097640	Kit portagrasso	Grease holder kit	Fetthaltersset	Kit porte-graisse	Kit soporte grasa				•	•				
34	✓		B0223000	Anello contenitore grasso	Grease holder ring	Fettführungsring	Anneau cuve porte-graisse	Anillo porta grasa	•	•	•	•	•				
35	✓		272038	TE M8x25	TE M8x25 bolt	Schraube TE M8x25	Vis TE M8x25	Tornillo TE M8x25	•	•			•				
	✓		272172	TE M8x16	TE M8x16 bolt	Schraube TE M8x16	Vis TE M8x16	Tornillo TE M8x16				•	•				
36	✓		710590670	Gruppo valvola di gonfiaggio 60 PSI	60 PSI inflation valve assembly	Aufpumpventilsatz 60 PSI	Ensemble soupape de gonflage 60 PSI	Conjunto válvula de inflado 60 PSI	•	•	•	•	•				
37	✓		599074	Pressacavo	Cable press	Kabeldurchführung	Presse-câble	Prensaestopas	•	•	•	•	•				
38	✓		730097670	Kit messa a terra	Grounding kit	Erdungsset	Kit mise à la terre	Kit puesta a tierra	•	•	•	•	•				
39	✓		790065110	Cavo di terra	Ground cable	Erdkabel	Câble de masse	Cable tierra	•	•	•	•	•				
40	✓		790065160	Cavo di terra	Ground cable	Erdkabel	Câble de masse	Cable tierra	•	•	•	•	•				
41	✓		203208	TE M5x20	TE M5x20 bolt	Schraube TE M5x20	Vis TE M5x20	Tornillo TE M5x20	•	•	•	•	•				
42	✓		203124	TE M5x30	TE M5x30 bolt	Schraube TE M5x30	Vis TE M5x30	Tornillo TE M5x30	•	•	•	•	•				



**LISTA DEI COMPONENTI - LIST OF COMPONENTS - TEILELISTE  
LISTE DES PIECES DETACHEES - LISTA DE PIEZAS**

**Tavola N° 1F - Rev. 1**

ASSIEME GENERALE  
MAIN ASSEMBLY  
GENERSATZ  
ASSEMBLAGE GENERAL  
JUNTO GENERAL

#		D.R	N	Descrizione	Description	Beschreibung	Description	Descripción	RAVG7645.201232	RAVG7645.200914	RAVG7645.200990	RAVG8645.201249	SPA.GA645.200600		
---	---	-----	---	-------------	-------------	--------------	-------------	-------------	-----------------	-----------------	-----------------	-----------------	------------------	---	---

43	✓		239017	Rosetta	Washer	Unterlegscheibe	Rondelle	Arandela	•	•	•	•	•		
44	✓		224005	Dado medio M5	M5 med nut	Mittlere Mutter M5	Écrou moyen M5	Tuerca media M5	•	•	•	•	•		
45	✓		730026450	Carter superiore per telaio	Upper guard for frame	Oberes Gehäuse für Rahmen	Carter supérieur pour châssis	Cárter superior para bastidor	•				•		

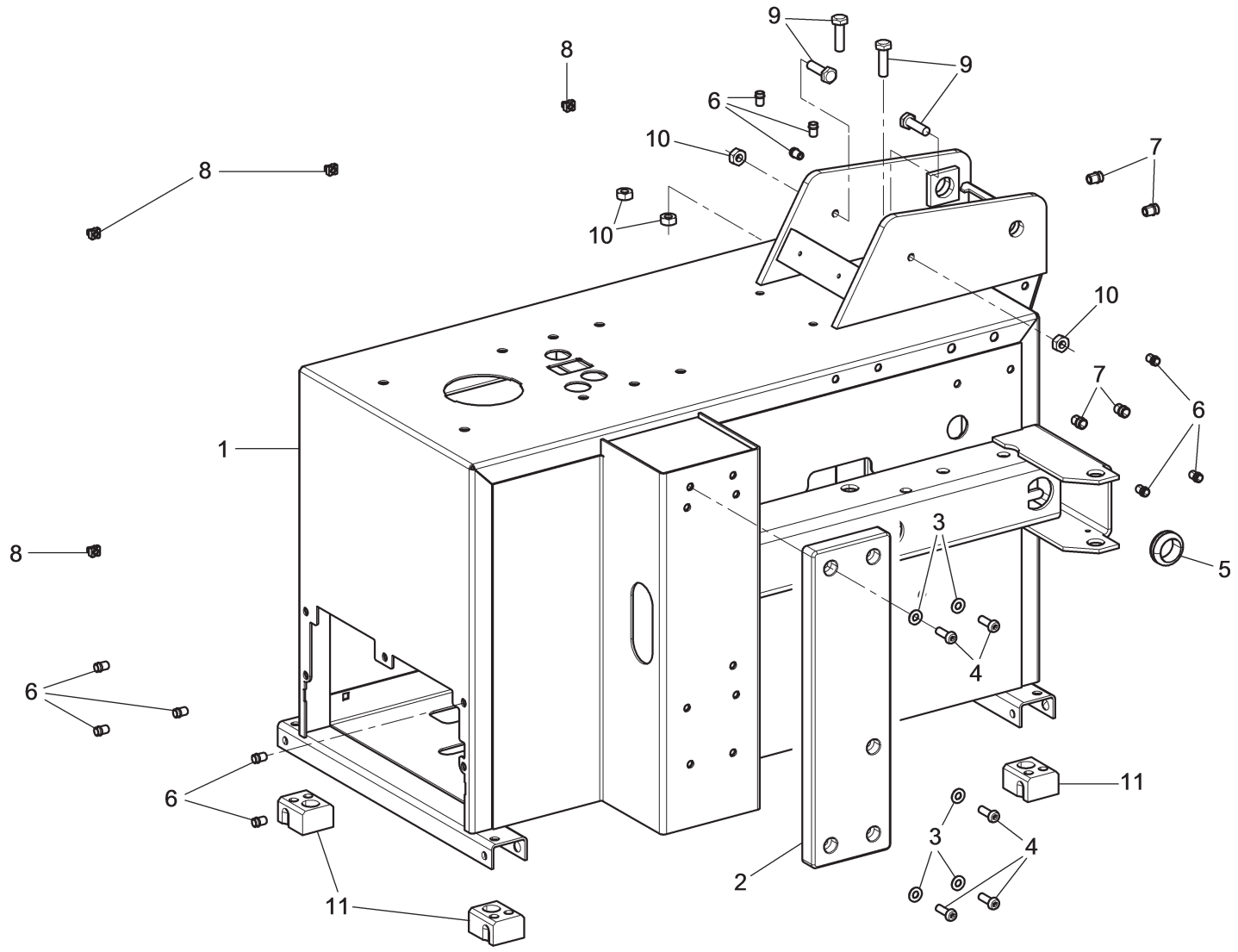

ROT. HP441.201102	ROT. HP641.200838	ROT. HF641.201034	ROT. HP641.200891	ROT. HF641.200785	ROT.HF641.201063 ROT.HF641.201788	ROT. HP641.201072	ROT. HF641.201065	ROT. HP641.201897	ROT.HF643.200894 ROT.HF643.201881	ROT. HP643.201133	ROT. HF643.200983	RAV. G7441.201140	RAV. G7441.200969	RAV. G7441.201119	RAV. G7441.200716	RAV. G7441.200877	RAV. G7441.200821	RAV. G7641.200945	RAV. G7641.200006	RAV. G7641.201041	RAV.G7641.200907 RAV.G7641.200683	RAV. G7641.201010	RAV. G7641.201089	RAV. G7641.200761	RAV. G7645.201232	RAV. G7645.200914	RAV. G7645.200990	RAV. G8645.201249	SFA. GA441.200976	SFA. GA441.201126	SFA. GA441.202000	SFA. GA641.201027	SFA. GA641.201096	SFA. GA641.200952	SFA. GA641.201058	SFA. GA645.200600			
•												•	•	•	•	•	•												•	•	•								
		<b>LISTA DEI COMPONENTI - LIST OF COMPONENTS - TEILELISTE</b> <b>LISTE DES PIÈCES DÉTACHÉES - LISTA DE PIEZAS</b>																			GRUPPO TELAIO FRAME ASSEMBLY RAHMENSATZ ENSEMBLE CHÂSSIS CONJUNTO BASTIDOR																		
		<b>Tavola N°2A - Rev. 1</b>												<b>730098460</b>							<b>Pag. 35 di 235</b>																		



**LISTA DEI COMPONENTI - LIST OF COMPONENTS - TEILELISTE**  
**LISTE DES PIECES DETACHEES - LISTA DE PIEZAS**

**Tavola N°2A - Rev. 1**

**730098460**

GRUPPO TELAIO  
 FRAME ASSEMBLY  
 RAHMENSATZ  
 ENSEMBLE CHÂSSIS  
 CONJUNTO BASTIDOR



ROT. HP441.201102	ROT. HP641.200938	ROT. HP641.201034	ROT. HP641.200891	ROT. HP641.200785	ROT. HP641.201003	ROT. HP641.201788	ROT. HP641.201072	ROT. HP641.201065	ROT. HP641.201997	ROT. HP643.200984	ROT. HP643.201681	ROT. HP643.201133	ROT. HP643.200983	RAV. G7441.201140	RAV. G7441.200969	RAV. G7441.201119	RAV. G7441.200716	RAV. G7441.200877	RAV. G7441.200921	RAV. G7641.200945	RAV. G7641.200006	RAV. G7641.201041	RAV. G7641.200807	RAV. G7641.200689	RAV. G7641.201010	RAV. G7641.201089	RAV. G7641.200761	RAV. G7645.201232	RAV. G7645.200914	RAV. G7645.200990	RAV. G8645.201249	SFA. GA441.200976	SFA. GA441.201126	SFA. GA441.202000	SFA. GA641.201027	SFA. GA641.201096	SFA. GA641.200952	SFA. GA641.201058	SFA. GA645.200600		
•													•	•	•	•	•	•													•	•	•								

#		D.R	N	Descrizione	Description	Beschreibung	Description	Descripción	▶	▶
---	--	-----	---	-------------	-------------	--------------	-------------	-------------	---	---

1	✓		730023353	Telaio saldato	Roller conveyor frame	Rollenbahng Rahmen	Châssis unsemble rouleaux	Bastidor via de rodillos		
2	✓		B4382000	Tampone	Pad	Puffer	Tampon	Tampón		
3	✓		236006	Rondella piana 8,4	8.4 flat washer	Ebene Unterlagsscheibe 8,4	Rondelle plane 8,4	Arandela plana 8,4		
4	✓		271038	TBEI M8x25	TBEI M8x25 bolt	Schraube TBEI M8x25	Vis TBEI M8x25	Tornillo TBEI M8x25		
5	✓		599418	Passacavo in gomma	Rubber-made hose clamp	Kabeldurchgang aus Gummi	Guide-câble en caoutchouc	Pasacable de goma		
6	✓		251107	Insero filettato M6	M6 threaded insert	Gewindeinsatz M6	Renfort fileté M6	Insero roscado M6		
7	✓		251109	Insieme filettato	Threaded assembly	Gewindesatz	Ensemble fileté	Conjunto roscado		
8	✓		228250	Dado in gabbia M6	M6 caged nut	Mutter im Käfig M6	Écrou en cage M6	Tuerca en jaula M6		
9	✓		730015010	Vite	Bolt	Schraube	Vis	Tornillo		
10	✓		224011	Dado esagonale medio M10	M10 med. hex nut	Mittlere Sechskantmutter M10	Écrou hexagonal moyen M10	Tuerca hexagonal medio M10		
11	✓		140315440	Piedino	Foot	Fuß	Pied	Pie		

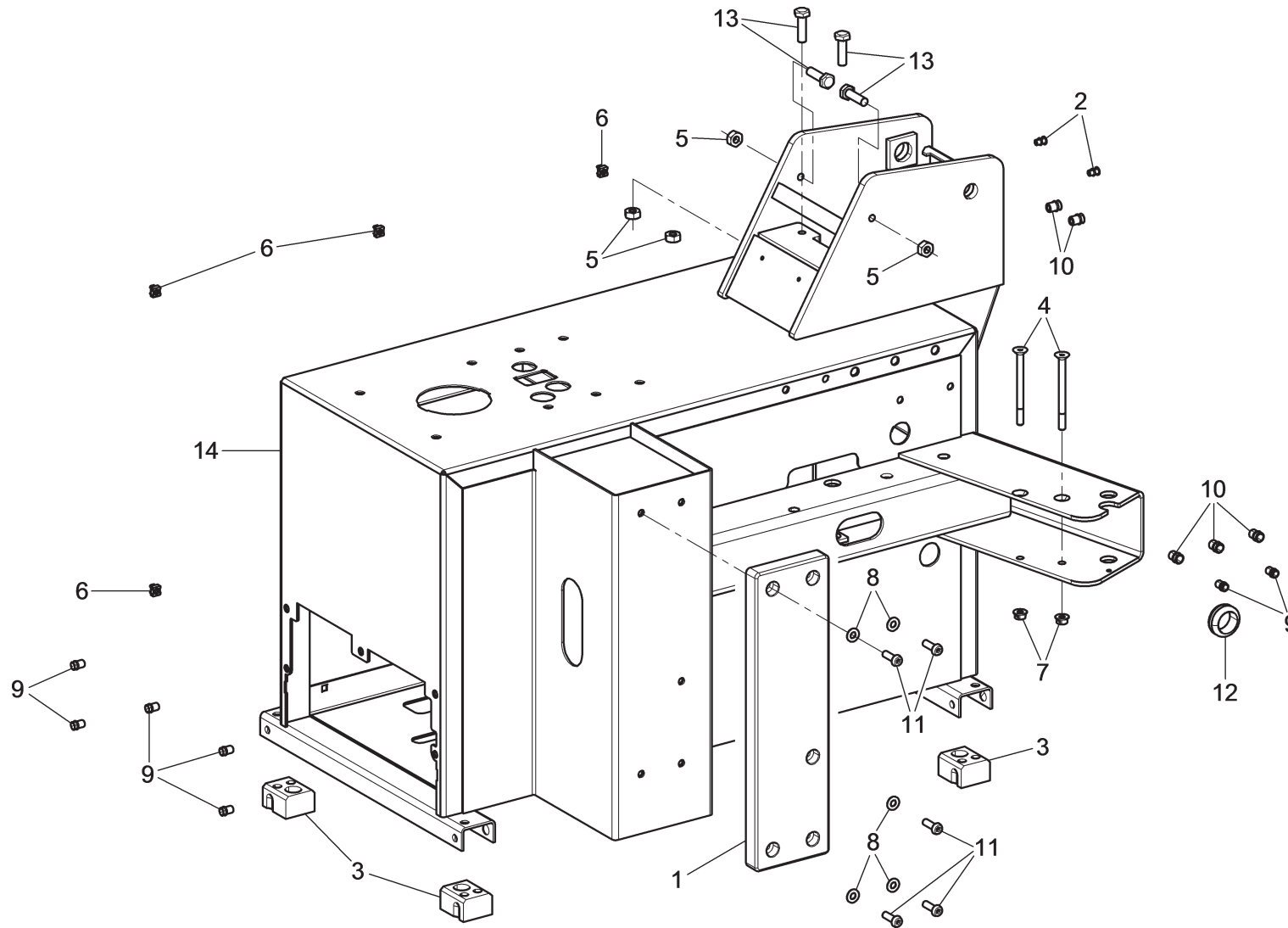

ROT. HP441.201102	ROT. HP641.200838	ROT. HF641.201034	ROT. HP641.200891	ROT. HF641.200785	ROT.HP641.201003 ROT.HP641.201788	ROT. HP641.201072	ROT. HP641.201065	ROT. HP641.201897	ROT.HP643.200894 ROT.HP643.201881	ROT. HP643.201133	ROT. HF643.200983	RAV. G7441.201140	RAV. G7441.200969	RAV. G7441.201119	RAV. G7441.200716	RAV. G7441.200877	RAV. G7441.200821	RAV. G7641.200945	RAV. G7641.200006	RAV. G7641.201041	RAV.G7641.200907 RAV.G7641.200683	RAV. G7641.201010	RAV. G7641.201089	RAV. G7641.200761	RAV. G7645.201232	RAV. G7645.200914	RAV. G7645.200990	RAV. G8645.201249	SFA. GA441.200976	SPA. GA441.201126	SPA. GA441.202000	SPA. GA641.201027	SPA. GA641.201096	SPA. GA641.200952	SPA. GA641.201058	SPA. GA645.200600		
	•	•	•	•	•	•	•	•										•	•	•	•	•	•										•	•	•	•	•	
		<b>LISTA DEI COMPONENTI - LIST OF COMPONENTS - TEILELISTE</b> <b>LISTE DES PIÈCES DÉTACHÉES - LISTA DE PIEZAS</b>																		GRUPPO TELAIO FRAME ASSEMBLY RAHMENSATZ ENSEMBLE CHÂSSIS CONJUNTO BASTIDOR										▶								
		<b>Tavola N°2B - Rev. 0</b>												<b>730098100</b>						<b>Pag. 37 di 235</b>																		



LISTA DEI COMPONENTI - LIST OF COMPONENTS - TEILELISTE  
LISTE DES PIECES DETACHEES - LISTA DE PIEZAS

GRUPPO TELAIO  
FRAME ASSEMBLY  
RAHMENSATZ  
ENSEMBLE CHÂSSIS  
CONJUNTO BASTIDOR





Pag. 38 di 235

Tavola N°2B - Rev. 0

730098100

#	D.R	N	Descrizione	Description	Beschreibung	Description	Descrpción		
1	✓		B4382000	Tampone	Pad	Puffer	Tampon	Tampón	
2	✓		B5837000	Inserto filettato M5	M5 threaded insert	Gewindeinsatz M5	Renfort fileté M5	Inserto roscado M5	
3	✓		140315440	Piedino	Foot	Fuß	Pied	Pie	
4	✓		209352	TPSEI M8x100	TSPEI M8x100 bolt	Schraube TSPEI M8x100	Vis TSPEI M8x100	Tornillo TSPEI M8x100	
5	✓		224011	Dado esagonale medio M10	M10 med. hex nut	Mittlere Sechskantmutter M10	Écrou hexagonal moyen M10	Tuerca hexagonal medio M10	
6	✓		228250	Dado in gabbia M6	M6 caged nut	Mutter im Käfig M6	Écrou en cage M6	Tuerca en jaula M6	
7	✓		228302	Dado biblock M8	M8 biblock nut	Biblock Mutter M8	Écrou biblock M8	Tuerca biblock M8	
8	✓		236006	Rondella piana 8,4	8.4 flat washer	Ebene Unterlagsscheibe 8,4	Rondelle plane 8,4	Arandela plana 8,4	
9	✓		251107	Inserto filettato M6	M6 threaded insert	Gewindeinsatz M6	Renfort fileté M6	Inserto roscado M6	
10	✓		251109	Insieme filettato	Threaded assembly	Gewindesatz	Ensemble fileté	Conjunto roscado	
11	✓		271038	TBEI M8x25	TBEI M8x25 bolt	Schraube TBEI M8x25	Vis TBEI M8x25	Tornillo TBEI M8x25	
12	✓		599418	Passacavo in gomma	Rubber-made hose clamp	Kabeldurchgang aus Gummi	Guide-câble en caoutchouc	Pasacable de goma	
13	✓		730015010	Vite	Bolt	Schraube	Vis	Tornillo	
14	✓		730025922	Telaio saldato	Roller conveyor frame	Rollenbahnrahmen	Châssis wsemble rouleaux	Bastidor via de rodillos	



			<b>LISTA DEI COMPONENTI - LIST OF COMPONENTS - TEILELISTE</b> <b>LISTE DES PIÈCES DÉTACHÉES - LISTA DE PIEZAS</b>										KIT BASAMENTO CON INSERTI BASE KIT WITH INSERTS GRUNDPLATTENSET MIT EINSÄTZE KIT BÂTI AVEC RENFORTS KIT BASE CON INSERTOS				<b>Pag. 40 di 235</b>																																
			<b>Tavola N°2C - Rev. 1</b>					<b>730099670</b>																																									
ROT. HP441.201102	ROT. HP641.200938	ROT. HP641.201034	ROT. HP641.200891	ROT. HP641.200785	ROT. HP641.201003	ROT. HP641.201788	ROT. HP641.201072	ROT. HP641.201065	ROT. HP641.201997	ROT. HP643.200984	ROT. HP643.201681	ROT. HP643.201133	ROT. HP643.200983	RAV G7441.201140	RAV G7441.200969	RAV G7441.201119	RAV G7441.200716	RAV G7441.200877	RAV G7441.200921	RAV G7641.200945	RAV G7641.200006	RAV G7641.201041	RAV G7641.200907	RAV G7641.200989	RAV G7641.201010	RAV G7641.201089	RAV G7641.200761	RAV G7645.201232	RAV G7645.200914	RAV G7645.200990	RAV G8645.201249	SFA GA441.200976	SFA GA441.201126	SFA GA441.202000	SFA GAG41.201027	SFA GAG41.201096	SFA GAG41.200952	SFA GAG41.201058	SFA GAG45.200600										
											•	•	•																																				•
<b>#</b>		<b>D.R</b>	<b>N</b>	<b>Descrizione</b>	<b>Description</b>	<b>Beschreibung</b>	<b>Description</b>	<b>Descripción</b>																																									

1	✓		730023163	Telaio saldato	Roller conveyor frame	Rollenbahnrahmen	Châssis wsemble rouleaux	Bastidor via de rodillos		
2	✓		599418	Passacavo in gomma	Rubber-made hose clamp	Kabeldurchgang aus Gummi	Guide-câble en caoutchouc	Pasacable de goma		
3	✓		271038	TBEI M8x25	Bolt TBEI M8x25	Schraube TBEI M8x25	Vis TBEI M8x25	Tornillo TBEI M8x25		
4	✓		B5837000	Inserto filettato M5	Threaded insert M5	Gewindeinsatz M5	Renfort fileté M5	Inserto roscado M5		
5	✓		251107	Inserto filettato M6	Threaded insert M6	Gewindeinsatz M6	Renfort fileté M6	Inserto roscado M6		
6	✓		228250	Dado in gabbia M6	Caged nut M6	Mutter im Käfig M6	Écrou en cage M6	Tuerca en jaula M6		
7	✓		224015	Dado esagonale medio M12	Med. hex nut M12	Mittlere Sechskantmutter M12	Écrou hexagonal moyen M12	Tuerca hexagonal medio M12		
8	✓		203223	TE M12x40	Bolt TE M12x40	Schraube TE M12x40	Vis TE M12x40	Tornillo TE M12x40		
9	✓		251104	Insieme filettato	Threaded assembly	Gewindesatz	Ensemble fileté	Conjunto roscado		
10	✓		251109	Insieme filettato	Threaded assembly	Gewindesatz	Ensemble fileté	Conjunto roscado		
11	✓		236006	Rondella piana 8,4	Flat washer 8.4	Ebene Unterlagsscheibe 8,4	Rondelle plane 8,4	Arandela plana 8,4		
12	✓		730018871	Tampone laterale	Lateral pad	Seitlicher Puffer	Tampon latéral	Tampón lateral		
13	✓		730015010	Vite	Bolt	Schraube	Vis	Tornillo		
14	✓		224011	Dado esagonale medio M10	Med. hex nut M10	Mittlere Sechskantmutter M10	Écrou hexagonal moyen M10	Tuerca hexagonal medio M10		
15	✓		140315440	Piedino	Foot	Fuß	Pied	Pie		
16	✓		599067	Passacavo	Hose clamp	Kabeldurchgang	Guide-câble	Pasacable		

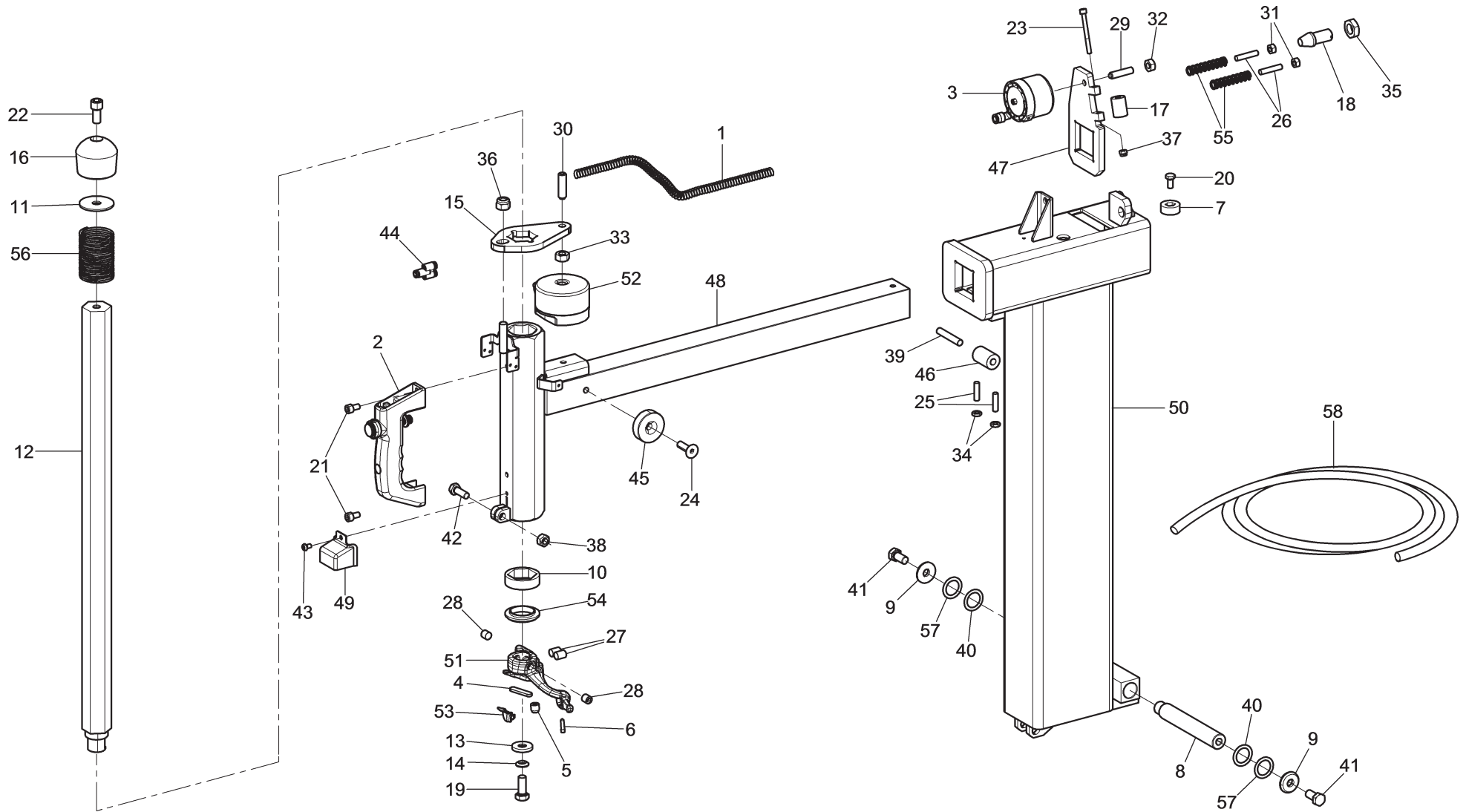

ROT. HP441.201102	ROT. HP641.200888	ROT. HF641.201034	ROT. HP641.200891	ROT. HF641.200785	ROT. HP641.201003	ROT. HP641.201788	ROT. HF641.201072	ROT. HF641.201065	ROT. HP641.201897	ROT. HP643.200894	ROT. HP643.201881	ROT. HP643.201133	ROT. HF643.200983	RAV. G7441.201140	RAV. G7441.200969	RAV. G7441.201119	RAV. G7441.200716	RAV. G7441.200877	RAV. G7441.200821	RAV. G7641.200945	RAV. G7641.200006	RAV. G7641.201041	RAV. G7641.200907	RAV. G7641.200683	RAV. G7641.201010	RAV. G7641.201089	RAV. G7641.200761	RAV. G7645.201232	RAV. G7645.200914	RAV. G7645.200990	RAV. G8645.201249	SFA. GA441.200976	SFA. GA441.201126	SFA. GA441.202000	SFA. GA641.201027	SFA. GA641.201096	SFA. GA641.200952	SFA. GA641.201058	SFA. GA645.200600						
•	•	•	•	•	•	•	•	•	•	•	•	•	•	•	•	•	•	•	•	•	•	•	•	•	•	•	•	•	•	•	•	•	•	•	•	•	•	•	•	•	•	•	•	•	•
		<b>LISTA DEI COMPONENTI - LIST OF COMPONENTS - TEILELISTE</b> <b>LISTE DES PIECES DETACHEES - LISTA DE PIEZAS</b>																			KIT PALO POST KIT STANGENSET KIT POTEAU KIT PALO							▶																	
		<b>Tavola N°3A - Rev. 0</b>											<b>730098120</b>								<b>Pag. 41 di 235</b>																								

ROT. HP441.201102	ROT. HP641.200938	ROT. HP641.201034	ROT. HP641.200891	ROT. HP641.200785	ROT. HP641.201003	ROT. HP641.201788	ROT. HP641.201072	ROT. HP641.201065	ROT. HP641.201997	ROT. HP643.200984	ROT. HP643.201681	ROT. HP643.201133	ROT. HP643.200983	RAV. G7441.201140	RAV. G7441.200969	RAV. G7441.201119	RAV. G7441.200716	RAV. G7441.200877	RAV. G7441.200921	RAV. G7641.200945	RAV. G7641.200006	RAV. G7641.201041	RAV. G7641.200907	RAV. G7641.200689	RAV. G7641.201010	RAV. G7641.201089	RAV. G7641.200761	RAV. G7645.201232	RAV. G7645.200914	RAV. G7645.200990	RAV. G8645.201249	SFA. GA441.200976	SFA. GA441.201126	SFA. GA441.202000	SFA. GA641.201027	SFA. GA641.201096	SFA. GA641.200952	SFA. GA641.201058	SFA. GA645.200600			
●	●	●	●	●	●	●	●		●					●	●	●	●	●	●	●	●	●	●	●	●	●	●	●	●	●	●	●	●	●	●	●	●	●	●	●	●	●
#		D.R	N	Descrizione	Description	Beschreibung	Description	Descripción																																		

1	✓		B1408300	Molla 1x14x600	1x14x600 spring	Feder 1x14x600	Ressort 1x14x600	Resorte 1x14x600			
2	✓		B2859001	Maniglia completa C	C complete handle	Vollkommen Handgriff C	Poignée complète C	Manija completa C			
3	✓		B2871000	Cilindro strangolo posteriore	Rear neck cylinder	Vordere Sperrvorrichtungszylinder	Cylindre étranglement postérieur	Cilindro dispositivo de bloqueo posterior			
4	✓		B9837000	Protezione coda utensile	Tool tail guard	Werkzeugschutzgehäuse	Protection queue outil	Protección cola útil			
5	✓		B9874000	Rullino per utensile montaggio	Roller for assembling tool	Rolle für Montagewerkzeug	Rouleau pour outil montage	Rodillo para útil montaje			
6	✓		B9875000	Perno rullo utensile	Tool roller pin	Rollezapfen des Montagewerkzeugs	Pivot rouleau outil	Perno rodillo útil montaje			
7	✓		13830247	Tampone	Pad	Puffer	Tampon	Tampón			
8	✓		140315212	Perno	Pin	Zapfen	Pivot	Perno			
9	✓		140315391	Distanziale	Spacer	Abstandsstück	Entretoise	Distanciador			
10	✓		140315721	Tampone esagonale 40	40 hex-nut pad	Sechskantpuffer 40	Tampon hexagonal 40	Tampón hexágono 40			
11	✓		140320310	Rondella	Washer	Unterlagsscheibe	Rondelle	Arandela			
12	✓		140415391	Albero	Shaft	Welle	Arbre	Eje			
13	✓		140440380	Rondella fermo torretta	Tower stopper washer	Scheibe für Turmsperre	Rondelle arrêt	Arandela de seguro torreta			
14	✓		140440390	Rosetta sferica	Ball washer	Kugelscheibe	Rondelle sphérique	Arandela esférica			
15	✓		140710092	Strangolo	Neck	Sperrvorrichtung	Étrangement	Dispositivo de bloqueo			
16	✓		140710160	Impugnatura albero verticale	Vertical shaft handgrip	Senkrechtwellehandgriff	Poignée arbre verticale	Empuñadura eje vertical			
17	✓		140910700	Rullino strangolo	Neck roller	Sperrvorrichtungsrolle	Rouleau étranglement	Rodillo dispositivo de bloqueo			
18	✓		140910711	Cono strangolo	Neck cone	Sperrvorrichtungskegel	Cône étranglement	Cono dispositivo de bloqueo			
19	✓		203072	TE M12x30	TE M12x30 bolt	Schraube TE M12x30	Vis TE M12x30	Tornillo TE M12x30			
20	✓		203172	TE M8x16	TE M8x16 bolt	Schraube TE M8x16	Vis TE M8x16	Tornillo TE M8x16			
21	✓		206031	TCEI M8x14	TCEI M8x14 bolt	Schraube TCEI M8x14	Vis TCEI M8x14	Tornillo TCEI M8x14			
22	✓		206186	TCEI M12x25	TCEI M12x25 bolt	Schraube TCEI M12x25	Vis TCEI M12x25	Tornillo TCEI M12x25			
23	✓		206335	TCEI M6x65	TCEI M6x65 bolt	Schraube TCEI M6x65	Vis TCEI M6x65	Tornillo TCEI M6x65			
24	✓		209106	TPSEI M10x35	TSPEI M10x35 bolt	Schraube TPSEI M10x35	Vis TPSEI M10x35	Tornillo TSPEI M10x35			
25	✓		210040	STEI M8x30	STEI M8x30 bolt	Schraube STEI M8x30	Vis STEI M8x30	Tornillo STEI M8x30			
26	✓		210042	STEI piana M8x40	M8x40 STEI flat bolt	Flachschaube STEI M8x40	Vis STEI plane M8x40	Tornillo STEI plana M8x40			
27	✓		210069	STEI piana M12x16	M12x16 STEI flat bolt	Flachschaube STEI M12x16	Vis STEI plane M12x16	Tornillo STEI plana M12x16			
28	✓		210317	STEI piana M12x12	M12x12 STEI flat bolt	Flachschaube STEI M12x12	Vis STEI plane M12x12	Tornillo STEI plana M12x12			
29	✓		210902	STEI M10x41,9	STEI M10x41.9 bolt	Schraube STEI M10x41,9	Vis STEI M10x41,9	Tornillo STEI M10x41,9			
30	✓		210904	STEI M12x42.1	STEI M12x42.1 bolt	Schraube STEI M12x42.1	Vis STEI M12x42.1	Tornillo STEI M12x42.1			
31	✓		224009	Dado esagonale medio M8	M8 med. hex nut	Mittlere Sechskantmutter M8	Écrou hexagonal moyen M8	Tuerca hexagonal medio M8			
32	✓		224011	Dado esagonale medio M10	M10 med. hex nut	Mittlere Sechskantmutter M10	Écrou hexagonal moyen M10	Tuerca hexagonal medio M10			

**Tavola N°3A - Rev. 0**

**730098120**

ROT. HP641.201102	ROT. HP641.200938	ROT. HP641.201034	ROT. HP641.200891	ROT. HP641.200785	ROT. HP641.201003	ROT. HP641.201788	ROT. HP641.201072	ROT. HP641.201065	ROT. HP641.201997	ROT. HP643.200984	ROT. HP643.201681	ROT. HP643.201133	ROT. HP643.200983	RAV. G7441.201140	RAV. G7441.200969	RAV. G7441.201119	RAV. G7441.200716	RAV. G7441.200877	RAV. G7441.200921	RAV. G7641.200945	RAV. G7641.200006	RAV. G7641.201041	RAV. G7641.200907	RAV. G7641.200689	RAV. G7641.201010	RAV. G7641.201089	RAV. G7641.200761	RAV. G7645.201232	RAV. G7645.200914	RAV. G7645.200990	RAV. G8645.201249	SFA. GA441.200976	SFA. GA441.201126	SFA. GA441.202000	SFA. GAG41.201027	SFA. GAG41.201096	SFA. GAG41.200952	SFA. GAG41.201058	SFA. GAG45.200600				
●	●	●	●	●	●	●	●		●					●	●	●	●	●	●	●	●	●	●	●	●	●	●	●	●	●	●	●	●	●	●	●	●	●	●	●	●	●	●
#		D.R	N	Descrizione	Description	Beschreibung	Description	Descripción																																			

33	✓		224015	Dado esagonale medio M12	M12 med hex nut	Mittlere Sechskantmutter M12	Écrou hexagonal moyen M12	Tuerca hexagonal medio M12			
34	✓		226009	Dado basso M8	M8 jam nut	Untere Mutter M8	Écrou bas M8	Tuerca baja M8			
35	✓		226024	Dado esagonale basso M18	M18 jam hex nut	Niedrige Sechskantmutter M18	Écrou hexagonal bas M18	Tuerca hexagonal baja M18			
36	✓		228006	Dado autobloccante M12	M12 self-locking nut	Selbstsichernde Mutter M12	Écrou auto-bloquant M12	Tuerca autoblocante M12			
37	✓		228010	Dado autobloccante M6	M6 self-locking nut	Selbstsichernde Mutter M6	Écrou auto-bloquant M6	Tuerca autoblocante M6			
38	✓		228310	Dado M10	M10 nut	Mutter M10	Écrou M10	Tuerca M10			
39	✓		234081	Spina cilindrica 10x60	10x60 cylindrical pin	Zylinderszapfen 10x60	Goupille cylindrique 10x60	Clavija cilíndrica 10x60			
40	✓		237501	Rondella di spessore	Shim washer	Beilagscheibe	Rondelle d'épaisseur	Arandela de espesor			
41	✓		256186	TE M12x25	TE M12x25 bolt	Schraube TE M12x25	Vis TE M12x25	Tornillo TE M12x25			
42	✓		256902	TE M10x30	TE M10x30 bolt	Schraube M10x30	Vis TE M10x30	Tornillo TE M10x30			
43	✓		271012	TBEI M6x10	TBEI M6x10 bolt	Schraube TBEI M6x10	Vis TBEI M6x10	Tornillo TBEI M6x10			
44	✓		325191	Raccordo pneumatico Y-6	Y-6 pneumatic fitting	Pneumatischer Y-Anschluss 6	Raccord pneumatique Y-6	Empalme neumático Y-6			
45	✓		730012451	Tampone	Pad	Puffer	Tampon	Tampón			
46	✓		730014560	Rullino	Roller	Rolle	Rouleau	Rodillo			
47	✓		730014580	Strangolo posteriore	Rear neck	Hintersperrvorrichtung	Étranglement arrière	Dispositivo de bloqueo posterior			
48	✓		730017173	Trave orizzontale	Horizontal square	Horizontaler Träger	Poutre horizontale	Viga horizontal			
49	✓		730017850	Carter	Guard	Gehäuse	Carter	Cárter			
50	✓		730019050	Palo saldato	Welded post	Geschweißte Stange	Poteau soudé	Palo soldado			
51	✓		730019300	Utensile di montaggio	Toolhead	Montagewerkzeug	Outil de montage	Útil de montaje			
52	✓		730093400	Cilindro strangolo D.80	D.80 neck cylinder	Sperrvorrichtungszylinder D.80	Cylindre étranglement D.80	Cilindro dispositivo de bloqueo D.80			
53	✓		770012480	Protezione per testa utensile	Protection for tool head	Schutzgehäuse für Werkzeugskopf	Protection pour tête outil	Protección para cabeza útil			
54	✓		790011540	Distanziale per esagono	Spacer for hex-nut	Abstandsstück für Sechskant	Entretoise pour hexagone	Distanciadador para hexágono			
55	✓		950001510	Molla	Spring	Feder	Ressort	Resorte			
56	✓		950001641	Molla	Spring	Feder	Ressort	Resorte			
57	✓		237511	Rondella di spessore	Shim washer	Beilagscheibe	Rondelle d'épaisseur	Arandela de espesor			
58	✓		317006	Tube rilsan 6x4 nero	6x4 black rilsan hose	Rilsan Rohr 6x4 schwarz	Tuyau rilsan 6x4 noir	Tubo rilsan 6x4 negro			

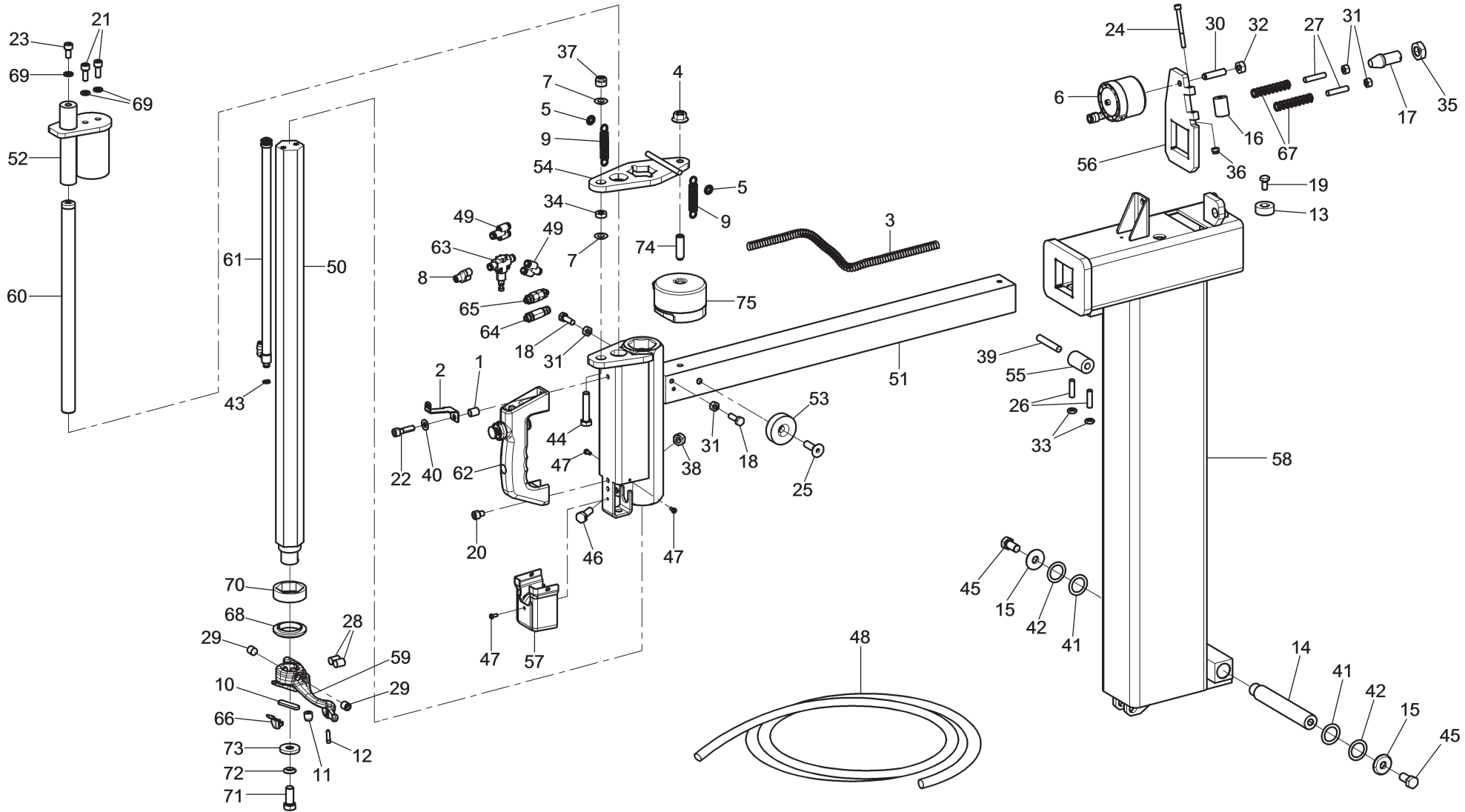

ROT. HP441.201102	ROT. HP641.200888	ROT. HP641.201034	ROT. HP641.200891	ROT. HP641.200785	ROT:HP641.201063 ROT:HP641.201788	ROT. HP641.201072	ROT. HP641.201065	ROT. HP641.201897	ROT:HP643.200894 ROT:HP643.201881	ROT. HP643.201133	ROT. HP643.200983	RAV. G7441.201140	RAV. G7441.200969	RAV. G7441.201119	RAV. G7441.200716	RAV. G7441.200877	RAV. G7441.200821	RAV. G7641.200945	RAV. G7641.200006	RAV. G7641.201041	RAV:G7641.200907 RAV:G7641.200683	RAV. G7641.201010	RAV. G7641.201089	RAV. G7641.200761	RAV. G7645.201232	RAV. G7645.200914	RAV. G7645.200990	RAV. G8645.201249	SPA. GA441.200976	SPA. GA441.201126	SPA. GA441.202000	SPA. GA641.201027	SPA. GA641.201096	SPA. GA641.200952	SPA. GA641.201058	SPA. GA645.200600
----------------------	----------------------	----------------------	----------------------	----------------------	--------------------------------------	----------------------	----------------------	----------------------	--------------------------------------	----------------------	----------------------	----------------------	----------------------	----------------------	----------------------	----------------------	----------------------	----------------------	----------------------	----------------------	--------------------------------------	----------------------	----------------------	----------------------	----------------------	----------------------	----------------------	----------------------	----------------------	----------------------	----------------------	----------------------	----------------------	----------------------	----------------------	----------------------



LISTA DEI COMPONENTI - LIST OF COMPONENTS - TEILELISTE  
 LISTE DES PIÈCES DÉTACHÉES - LISTA DE PIEZAS

Tavola N°3B - Rev. 0

730098270

KIT PALO  
 POST KIT  
 STANGENSET  
 KIT POTEAU  
 KIT PALO







Pag. 44 di 235



ROT. HP641.201102	ROT. HP641.200938	ROT. HP641.201034	ROT. HP641.200891	ROT. HP641.200785	ROT. HP641.201003	ROT. HP641.201788	ROT. HP641.201072	ROT. HP641.201065	ROT. HP641.201997	ROT. HP643.200984	ROT. HP643.201681	ROT. HP643.201133	ROT. HP643.200983	RAV. G7441.201140	RAV. G7441.200969	RAV. G7441.201119	RAV. G7441.200716	RAV. G7441.200877	RAV. G7441.200921	RAV. G7641.200945	RAV. G7641.200006	RAV. G7641.201041	RAV. G7641.200907	RAV. G7641.200689	RAV. G7641.201010	RAV. G7641.201089	RAV. G7641.200761	RAV. G7645.201232	RAV. G7645.200914	RAV. G7645.200990	RAV. G8645.201249	SFA. GA441.200976	SFA. GA441.201126	SFA. GA441.202000	SFA. GAG41.201027	SFA. GAG41.201096	SFA. GAG41.200952	SFA. GAG41.201058	SFA. GAG45.200600
----------------------	----------------------	----------------------	----------------------	----------------------	----------------------	----------------------	----------------------	----------------------	----------------------	----------------------	----------------------	----------------------	----------------------	----------------------	----------------------	----------------------	----------------------	----------------------	----------------------	----------------------	----------------------	----------------------	----------------------	----------------------	----------------------	----------------------	----------------------	----------------------	----------------------	----------------------	----------------------	----------------------	----------------------	----------------------	----------------------	----------------------	----------------------	----------------------	----------------------

#		D.R	N	Descrizione	Description	Beschreibung	Description	Descripción		
---	---	-----	---	-------------	-------------	--------------	-------------	-------------	---	---

1	✓		B1337900	Distanziale per M8	Spacer for M8	Abstandsstück für M8	Entretoise pour M8	Distanciador para M8		
2	✓		B1338100	Supporto carter	Guard support	Verleitungsträger	Support carter	Soporte cárter		
3	✓		B1408300	Molla 1x14x600	1x14x600 spring	Feder 1x14x600	Ressort 1x14x600	Resorte 1x14x600		
4	✓		B1897000	Dado flangiato M12	M12 flanged nut	Flanschmutter M12	Écrou flangé M12	Tuerca rebordeado M12		
5	✓		B1955000	Prestola 6/15/0,25	6/15/0.25 lock ring	Sicherungsring 6/15/0,25	Anneau de blocage 6/15/0,25	Anillo sujeción 6/15/0,25		
6	✓		B2871000	Cilindro strangolo posteriore	Rear neck cylinder	Vordere Sperrvorrichtungszylinder	Cylindre étranglement postérieur	Cilindro dispositivo de bloqueo posterior		
7	✓		B4058000	Rosetta Fe 10,5x21 sferica	Fe 10.5x21 ball washer	Kugelscheibe Fe 10,5x21	Rondelle Fe 10,5x21 sphérique	Arandela Fe 10,5x21 esférico		
8	✓		B5815000	Raccordo V D.4	Y D.4 fitting	D.4 „Y“-Anschluss	Raccord Y D.4	Empalme Y D.4		
9	✓		B5864000	Molla T	T spring	T-Feder	Ressort T	Resorte T		
10	✓		B9837000	Protezione coda utensile	Tool tail guard	Werkzeugschutzgehäuse	Protection queue outil	Protección cola útil		
11	✓		B9874000	Rullino per utensile montaggio	Roller for assembling tool	Rolle für Montagewerkzeug	Rouleau pour outil montage	Rodillo para útil montaje		
12	✓		B9875000	Perno rullo utensile	Tool roller pin	Rollezapfen des Montagewerkzeugs	Pivot rouleau outil	Perno rodillo útil montaje		
13	✓		13830247	Tampone	Pad	Puffer	Tampon	Tampón		
14	✓		140315212	Perno	Pin	Zapfen	Pivot	Perno		
15	✓		140315391	Distanziale	Spacer	Abstandsstück	Entretoise	Distanciador		
16	✓		140910700	Rullino strangolo	Neck roller	Sperrvorrichtungsrolle	Rouleau étranglement	Rodillo dispositivo de bloqueo		
17	✓		140910711	Cono strangolo	Neck cone	Sperrvorrichtungskegel	Cône étranglement	Cono dispositivo de bloqueo		
18	✓		203038	TE M8x25	TE M8x25 bolt	Schraube TE M8x25	Vis TE M8x25	Tornillo TE M8x25		
19	✓		203172	TE M8x16	TE M8x16 bolt	Schraube TE M8x16	Vis TE M8x16	Tornillo TE M8x16		
20	✓		206028	TCEI M8x10	TCEI M8x10 bolt	Schraube TCEI M8x10	Vis TCEI M8x10	Tornillo TCEI M8x10		
21	✓		206035	TCEI M8x20	TCEI M8x20 bolt	Schraube TCEI M8x20	Vis TCEI M8x20	Tornillo TCEI M8x20		
22	✓		206040	TCEI M8x30	TCEI M8x30 bolt	Schraube TCEI M8x30	Vis TCEI M8x30	Tornillo TCEI M8x30		
23	✓		206172	TCEI M8x16	TCEI M8x16 bolt	Schraube TCEI M8x16	Vis TCEI M8x16	Tornillo TCEI M8x16		
24	✓		206335	TCEI M6x65	TCEI M6x65 bolt	Schraube TCEI M6x65	Vis TCEI M6x65	Tornillo TCEI M6x65		
25	✓		209106	TPSEI M10x35	TSPEI M10x35 bolt	Schraube TPSEI M10x35	Vis TPSEI M10x35	Tornillo TSPEI M10x35		
26	✓		210040	STEI M8x30	STEI M8x30 bolt	Schraube STEI M8x30	Vis STEI M8x30	Tornillo STEI M8x30		
27	✓		210042	STEI piana M8x40	M8x40 STEI flat bolt	Flachschraube STEI M8x40	Vis STEI plane M8x40	Tornillo STEI plana M8x40		
28	✓		210069	STEI piana M12x16	M12x16 STEI flat bolt	Flachschraube STEI M12x16	Vis STEI plane M12x16	Tornillo STEI plana M12x16		
29	✓		210317	STEI piana M12x12	M12x12 STEI flat bolt	Flachschraube STEI M12x12	Vis STEI plane M12x12	Tornillo STEI plana M12x12		
30	✓		210902	STEI M10x41,9	STEI M10x41.9 bolt	Schraube STEI M10x41,9	Vis STEI M10x41,9	Tornillo STEI M10x41,9		
31	✓		224009	Dado esagonale medio M8	M8 med. hex nut	Mittlere Sechskantmutter M8	Écrou hexagonal moyen M8	Tuerca hexagonal medio M8		
32	✓		224011	Dado esagonale medio M10	M10 med. hex nut	Mittlere Sechskantmutter M10	Écrou hexagonal moyen M10	Tuerca hexagonal medio M10		

		<b>LISTA DEI COMPONENTI - LIST OF COMPONENTS - TEILELISTE</b> <b>LISTE DES PIÈCES DÉTACHÉES - LISTA DE PIEZAS</b>										KIT PALO POST KIT STANGENSET KIT POTEAU KIT PALO					<b>Pag. 46 di 235</b>																						
		<b>Tavola N°3B - Rev. 0</b>					<b>730098270</b>																																
ROT. HP641.201102	ROT. HP641.200938	ROT. HP641.201034	ROT. HP641.200891	ROT. HP641.200785	ROT. HP641.201003	ROT. HP641.201788	ROT. HP641.201072	ROT. HP641.201065	ROT. HP641.201997	ROT. HP643.200984	ROT. HP643.201681	ROT. HP643.201133	ROT. HP643.200983	RAV G7441.201140	RAV G7441.200969	RAV G7441.201119	RAV G7441.200716	RAV G7441.200877	RAV G7441.200921	RAV G7641.200945	RAV G7641.200006	RAV G7641.201041	RAV G7641.200907	RAV G7641.200689	RAV G7641.201010	RAV G7641.201089	RAV G7641.200761	RAV G7645.201232	RAV G7645.200914	RAV G7645.200990	RAV G8645.201249	SFA GA441.200976	SFA GA441.201126	SFA GA441.202000	SFA GA641.201027	SFA GA641.201096	SFA GA641.200952	SFA GA641.201058	SFA GA645.200600
●																																							
#		D.R	N	Descrizione	Description	Beschreibung	Description	Descripción																															

33	✓		226009	Dado basso M8	M8 jam nut	Untere Mutter M8	Écrou bas M8	Tuerca baja M8				
34	✓		226011	Dado esagonale basso M10	M10 jam hex nut	Niedrige Sechskantmutter M10	Écrou hexagonal bas M10	Tuerca hexagonal baja M10				
35	✓		226024	Dado esagonale basso M18	M18 jam hex nut	Niedrige Sechskantmutter M18	Écrou hexagonal bas M18	Tuerca hexagonal baja M18				
36	✓		228010	Dado autobloccante M6	M6 self-locking nut	Selbstsichernde Mutter M6	Écrou auto-bloquant M6	Tuerca autoblocante M6				
37	✓		228012	Dado autobloccante M10	M10 self-locking nut	Selbstsichernde Mutter M10	Écrou auto-bloquant M10	Tuerca autoblocante M10				
38	✓		228310	Dado M10	M10 nut	Mutter M10	Écrou M10	Tuerca M10				
39	✓		234081	Spina cilindrica 10x60	10x60 cylindrical pin	Zylinderszapfen 10x60	Goupille cylindrique 10x60	Clavija cilíndrica 10x60				
40	✓		236006	Rondella piana 8,4	8.4 flat washer	Ebene Unterlagsscheibe 8,4	Rondelle plane 8,4	Arandela plana 8,4				
41	✓		237501	Rondella di spessore	Shim washer	Beilagscheibe	Rondelle d'épaisseur	Arandela de espesor				
42	✓		237511	Rondella di spessore	Shim washer	Beilagscheibe	Rondelle d'épaisseur	Arandela de espesor				
43	✓		243003	Seeger esterno 10	External clip ring 10	Externer Seeger 10	Anneau de retenue extérieur 10	Seeger externo 10				
44	✓		256066	TE M10x50	TE M10x50 bolt	Schraube TE M10x50	Vis TE M10x50	Tornillo TE M10x50				
45	✓		256186	TE M12x25	TE M12x25 bolt	Schraube TE M12x25	Vis TE M12x25	Tornillo TE M12x25				
46	✓		256902	TE M10x30	TE M10x30 bolt	Schraube M10x30	Vis TE M10x30	Tornillo TE M10x30				
47	✓		266167	TBEI M4x10	TBEI M4x10 bolt	Schraube TBEI M4x10	Vis TBEI M4x10	Tornillo TBEI M4x10				
48	✓		317006	Tube rilsan 6x4 nero	6x4 black rilsan hose	Rilsan Rohr 6x4 schwarz	Tuyau rilsan 6x4 noir	Tube rilsan 6x4 negro				
49	✓		325191	Raccordo pneumatico Y-6	Y-6 pneumatic fitting	Pneumatischer Y-Anschluss 6	Raccord pneumatique Y-6	Empalme neumático Y-6				
50	✓		730011813	Esagono portautensile	Tool holder hex-nut	Werkzeugträgerschexkant	Hexagone porte-outil	Hexágono porta útil				
51	✓		730012223	Trave orizzontale	Horizontal square	Horizontaler Träger	Poutre horizontal	Viga horizontal				
52	✓		730012251	Cappuccio superiore	Upper cap	Oberere Haube	Capuchon supérieur	Capuchón superior				
53	✓		730012451	Tampone	Pad	Puffer	Tampon	Tampón				
54	✓		730012631	Strangolo	Neck	Sperrvorrichtung	Étranglement	Dispositivo de bloqueo				
55	✓		730014560	Rullino	Roller	Rolle	Rouleau	Rodillo				
56	✓		730014580	Strangolo posteriore	Rear neck	Hintersperrvorrichtung	Étranglement arrière	Dispositivo de bloqueo posterior				
57	✓		730017010	Carter anteriore	Front guard	Vorderes Gehäuse	Carter antérieur	Cárter anterior				
58	✓		730019050	Palo saldato	Welded post	Geschweißte Stange	Poteau soudé	Palo soldado				
59	✓		730019300	Utensile di montaggio	Toolhead	Montagewerkzeug	Outil de montage	Útil de montaje				
60	✓		730090361	Canna cilindro	Cylinder liner	Zylinderlaufbuchse	Chemise cylindre	Camisa cilindro				
61	✓		730090372	Corpo inferiore cilindro	Cylinder lower body	Unteres Zylindergehäuse	Corps inférieur cylindre	Cuerpo inferior cilindro				
62	✓		730091700	Maniglia completa	Complete handle	Kompletter Handgriff	Poignée complète	Manija completa				
63	✓		730096950	Regolatore di pressione	Pressure regulator	Druckregler	Régulateur de pression	Regulador de presión				

 VEHICLE SERVICE GROUP <small>a <b>LOWE</b> company</small>		<b>LISTA DEI COMPONENTI - LIST OF COMPONENTS - TEILELISTE</b> <b>LISTE DES PIECES DETACHEES - LISTA DE PIEZAS</b>															KIT PALO POST KIT STANGENSET KIT POTEAU KIT PALO				<b>Pag. 47 di 235</b> ▶ ▶																		
		<b>Tavola N°3B - Rev. 0</b>							<b>730098270</b>																														
ROT. HP441.201102	ROT. HP641.200938	ROT. HP641.201034	ROT. HP641.200891	ROT. HP641.200785	ROT. HP641.201003	ROT. HP641.201788	ROT. HP641.201072	ROT. HP641.201065	ROT. HP641.201997	ROT. HP643.200984	ROT. HP643.201881	ROT. HP643.201133	ROT. HP643.200983	RAV G7441.201140	RAV G7441.200969	RAV G7441.201119	RAV G7441.200716	RAV G7441.200877	RAV G7441.200921	RAV G7641.200945	RAV G7641.200006	RAV G7641.201041	RAV G7641.200907	RAV G7641.200893	RAV G7641.201010	RAV G7641.201089	RAV G7641.200761	RAV G7645.201232	RAV G7645.200914	RAV G7645.200990	RAV G8645.201249	SFA GA441.200976	SFA GA441.201126	SFA GA441.202000	SFA GAG41.201027	SFA GAG41.201096	SFA GAG41.200952	SFA GAG41.201058	SFA GAG45.200600
#		D.R	N	Descrizione		Description		Beschreibung		Description			Descripción			▶	▶																						

64	✓		730096980	Strozzatore da 1.1	Flow control valve from 1.1	Durchflussregler ab 1.1	Soupape de détente depuis 1.1	Regulador de caudal de 1.1		
65	✓		730096990	Strozzatore da 0,85	Flow control valve from 0.85	Durchflussregler ab 0,85	Soupape de détente depuis 0,85	Regulador de caudal de 0,85		
66	✓		770012480	Protezione per testa utensile	Protection for tool head	Schutzgehäuse für Werkzeugskopf	Protection pour tête outil	Protección para cabeza útil		
67	✓		950001510	Molla	Spring	Feder	Ressort	Resorte		
68	✓		790011540	Distanziale per esagono	Spacer for hex-nut	Abstandsstück für Sechskant	Entretoise pour hexagone	Distanciador para hexágono		
69	✓		238006	Rondella elastica 8,4	8.4 spring washer	Elastische Unterlagsscheibe 8,4	Rondelle elastique 8,4	Arandela elástica 8,4		
70	✓		140315721	Tampone esagonale 40	40 hex-nut pad	Sechskantpuffer 40	Tampon hexagonal 40	Tampón hexágono 40		
71	✓		203072	TE M12x30	TE M12x30 bolt	Schraube TE M12x30	Vis TE M12x30	Tornillo TE M12x30		
72	✓		140440390	Rosetta sferica	Ball washer	Kugelscheibe	Rondelle sphérique	Arandela esférica		
73	✓		140440380	Rondella fermo torretta	Tower stopper washer	Scheibe für Turmsperre	Rondelle arrêt	Arandela de seguro torreta		
74	✓		210904	STEI M12x42.1	STEI M12x42.1 bolt	Schraube STEI M12x42.1	Vis STEI M12x42.1	Tornillo STEI M12x42.1		
75	✓		730093400	Cilindro strangolo D.80	D.80 neck cylinder	Sperrvorrichtungszylinder D.80	Cylindre étranglement D.80	Cilindro dispositivo de bloqueo D.80		



Tavola N°3C - Rev. 0

730097720

ROT. HP641.201102	ROT. HP641.200938	ROT. HP641.201034	ROT. HP641.200891	ROT. HP641.200785	ROT. HP641.201003	ROT. HP641.201788	ROT. HP641.201072	ROT. HP641.201065	ROT. HP641.201997	ROT. HP643.200984	ROT. HP643.201681	ROT. HP643.201133	ROT. HP643.200983	RAV. G7441.201140	RAV. G7441.200969	RAV. G7441.201119	RAV. G7441.200716	RAV. G7441.200877	RAV. G7441.200821	RAV. G7641.200945	RAV. G7641.200006	RAV. G7641.201041	RAV. G7641.200907	RAV. G7641.200689	RAV. G7641.201010	RAV. G7641.201089	RAV. G7641.200761	RAV. G7645.201232	RAV. G7645.200914	RAV. G7645.200990	RAV. G7645.201249	SFA. GA441.200976	SFA. GA441.201126	SFA. GA441.202000	SFA. GA641.201027	SFA. GA641.201096	SFA. GA641.200952	SFA. GA641.201058	SFA. GA645.200600		
						●	●																		●	●	●														●
#	D.R	N	Descrizione	Description	Beschreibung	Description	Descripción																																		

1	✓		B1408300	Molla 1x14x600	1x14x600 spring	Feder 1x14x600	Ressort 1x14x600	Resorte 1x14x600		
2	✓		B2859001	Maniglia completa	Complete handle	Kompletter Handgriff	Poignée complète	Manija completa		
3	✓		B2871000	Cilindro strangolo posteriore	Rear neck cylinder	Vordere Sperrvorrichtungszylinder	Cylindre étranglement postérieur	Cilindro dispositivo de bloqueo posterior		
4	✓		B9837000	Protezione coda utensile	Tool tail guard	Werkzeugschutzgehäuse	Protection queue outil	Protección cola útil		
5	✓		B9874000	Rullino per utensile montaggio	Roller for assembling tool	Rolle für Montagewerkzeug	Rouleau pour outil montage	Rodillo para útil montaje		
6	✓		B9875000	Perno rullo utensile	Tool roller pin	Rollezapfen des Montagewerkzeugs	Pivot rouleau outil	Perno rodillo útil montaje		
7	✓		13830247	Tampone	Pad	Puffer	Tampon	Tampón		
8	✓		140315212	Perno	Pin	Zapfen	Pivot	Perno		
9	✓		140315391	Distanziale	Spacer	Abstandsstück	Entretoise	Distanciador		
10	✓		140315721	Tampone esagonale 40	40 hex-nut pad	Sechskantpuffer 40	Tampon hexagonal 40	Tampón hexágono 40		
11	✓		140320310	Rondella	Washer	Unterlagsscheibe	Rondelle	Arandela		
12	✓		140440380	Rondella fermo torretta	Tower stopper washer	Scheibe für Turmsperre	Rondelle arrêt	Arandela de seguro torreta		
13	✓		140440390	Rosetta sferica	Ball washer	Kugelscheibe	Rondelle sphérique	Arandela esférica		
14	✓		140710092	Strangolo	Neck	Sperrvorrichtung	Étranglement	Dispositivo de bloqueo		
15	✓		140710160	Impugnatura albero verticale	Vertical shaft handgrip	Senkrechtwellehandgriff	Poignée arbre verticale	Empuñadura eje vertical		
16	✓		140910700	Rullino strangolo	Neck roller	Sperrvorrichtungsrolle	Rouleau étranglement	Rodillo dispositivo de bloqueo		
17	✓		140910711	Cono strangolo	Neck cone	Sperrvorrichtungskegel	Cône étranglement	Cono dispositivo de bloqueo		
18	✓		203072	TE M12x30	TE M12x30 bolt	Schraube TE M12x30	Vis TE M12x30	Tornillo TE M12x30		
19	✓		203172	TE M8x16	TE M8x16 bolt	Schraube TE M8x16	Vis TE M8x16	Tornillo TE M8x16		
20	✓		206031	TCEI M8x14	TCEI M8x14 bolt	Schraube TCEI M8x14	Vis TCEI M8x14	Tornillo TCEI M8x14		
21	✓		206100	TCEI M6x60	TCEI M6x60 bolt	Schraube TCEI M6x60	Vis TCEI M6x60	Tornillo TCEI M6x60		
22	✓		206186	TCEI M12x25	TCEI M12x25 bolt	Schraube TCEI M12x25	Vis TCEI M12x25	Tornillo TCEI M12x25		
23	✓		209106	TPSEI M10x35	TSPEI M10x35 bolt	Schraube TSPEI M10x35	Vis TSPEI M10x35	Tornillo TSPEI M10x35		
24	✓		210040	STEI M8x30	STEI M8x30 bolt	Schraube STEI M8x30	Vis STEI M8x30	Tornillo STEI M8x30		
25	✓		210042	STEI piana M8x40	M8x40 STEI flat bolt	Flachschraube STEI M8x40	Vis STEI plane M8x40	Tornillo STEI plana M8x40		
26	✓		210069	STEI piana M12x16	M12x16 STEI flat bolt	Flachschraube STEI M12x16	Vis STEI plane M12x16	Tornillo STEI plana M12x16		
27	✓		210317	STEI piana M12x12	M12x12 STEI flat bolt	Flachschraube STEI M12x12	Vis STEI plane M12x12	Tornillo STEI plana M12x12		
28	✓		210902	STEI M10x41,9	STEI M10x41.9 bolt	Schraube STEI M10x41,9	Vis STEI M10x41,9	Tornillo STEI M10x41,9		
29	✓		210904	STEI M12x42,1	STEI M12x42.1 bolt	Schraube STEI M12x42,1	Vis STEI M12x42,1	Tornillo STEI M12x42,1		
30	✓		224009	Dado esagonale medio M8	M8 med. hex nut	Mittlere Sechskantmutter M8	Écrou hexagonal moyen M8	Tuerca hexagonal medio M8		
31	✓		224011	Dado esagonale medio M10	M10 med. hex nut	Mittlere Sechskantmutter M10	Écrou hexagonal moyen M10	Tuerca hexagonal medio M10		
32	✓		224015	Dado esagonale medio M12	M12 med hex nut	Mittlere Sechskantmutter M12	Écrou hexagonal moyen M12	Tuerca hexagonal medio M12		



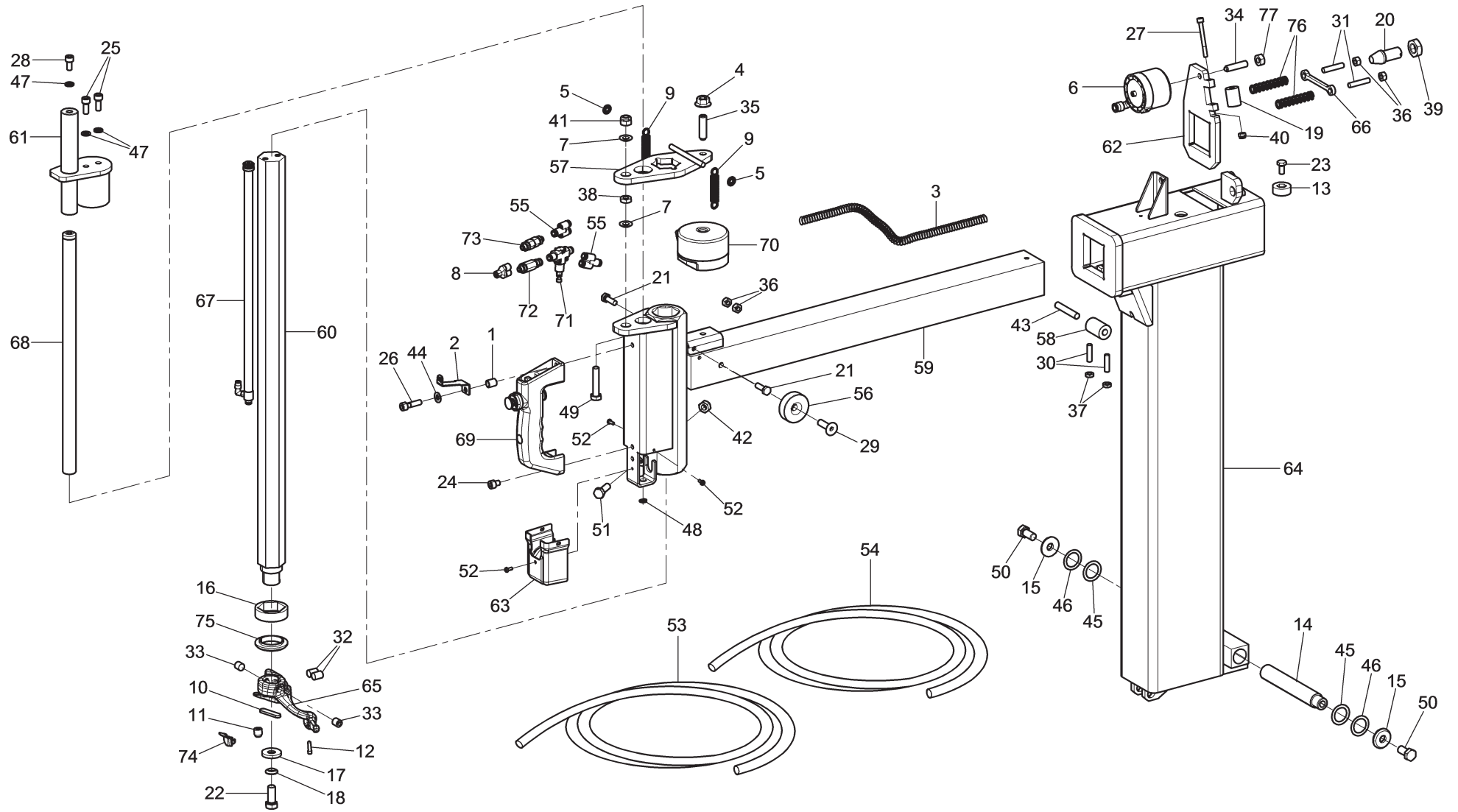

ROT. HP441.201102	ROT. HP641.200838	ROT. HP641.201034	ROT. HP641.200891	ROT. HP641.200785	ROT.HP641.201003 ROT.HP641.201788	ROT. HP641.201072	ROT. HP641.201065	ROT. HP641.201897	ROT.HP643.200894 ROT.HP643.201881	ROT. HP643.201133	ROT. HP643.200983	RAV. G7441.201140	RAV. G7441.200969	RAV. G7441.201119	RAV. G7441.200716	RAV. G7441.200877	RAV. G7441.200821	RAV. G7641.200945	RAV. G7641.200006	RAV. G7641.201041	RAV.G7641.200907 RAV.G7641.200683	RAV. G7641.201010	RAV. G7641.201089	RAV. G7641.200761	RAV. G7645.201232	RAV. G7645.200914	RAV. G7645.200990	RAV. G8645.201249	SPA. GA441.200976	SPA. GA441.201126	SPA. GA441.202000	SPA. GA641.201027	SPA. GA641.201096	SPA. GA641.200952	SPA. GA641.201058	SPA. GA645.200600
----------------------	----------------------	----------------------	----------------------	----------------------	--------------------------------------	----------------------	----------------------	----------------------	--------------------------------------	----------------------	----------------------	----------------------	----------------------	----------------------	----------------------	----------------------	----------------------	----------------------	----------------------	----------------------	--------------------------------------	----------------------	----------------------	----------------------	----------------------	----------------------	----------------------	----------------------	----------------------	----------------------	----------------------	----------------------	----------------------	----------------------	----------------------	----------------------







LISTA DEI COMPONENTI - LIST OF COMPONENTS - TEILELISTE  
LISTE DES PIÈCES DÉTACHÉES - LISTA DE PIEZAS





Tavola N°3D - Rev. 0

730097540



KIT PALO  
POST KIT  
STANGENSET  
KIT POTEAU  
KIT PALO

		<b>LISTA DEI COMPONENTI - LIST OF COMPONENTS - TEILELISTE</b> <b>LISTE DES PIÈCES DÉTACHÉES - LISTA DE PIEZAS</b>												KIT PALO POST KIT STANGENSET KIT POTEAU KIT PALO						<b>Pag. 52 di 235</b>																			
		<b>Tavola N°3D - Rev. 0</b>						<b>730097540</b>																															
ROT. HP641.201102	ROT. HP641.200938	ROT. HP641.201034	ROT. HP641.200891	ROT. HP641.200785	ROT. HP641.201003	ROT. HP641.201788	ROT. HP641.201072	ROT. HP641.201065	ROT. HP641.201997	ROT. HP643.200984	ROT. HP643.201681	ROT. HP643.201133	ROT. HP643.200983	RAV. G7441.201140	RAV. G7441.200969	RAV. G7441.201119	RAV. G7441.200716	RAV. G7441.200877	RAV. G7441.200921	RAV. G7641.200945	RAV. G7641.200006	RAV. G7641.201041	RAV. G7641.200907	RAV. G7641.200689	RAV. G7641.201010	RAV. G7641.201089	RAV. G7641.200761	RAV. G7645.201232	RAV. G7645.200914	RAV. G7645.200990	RAV. G8645.201249	SPA. GA441.200976	SPA. GA441.201126	SPA. GA441.202000	SPA. GA641.201027	SPA. GA641.201096	SPA. GA641.200952	SPA. GA641.201058	SPA. GA645.200600
●																																							
#		D.R	N	Descrizione	Description	Beschreibung	Description	Descripción																															

1	✓		B1337900	Distanziale per M8	Spacer for M8	Abstandsstück für M8	Entretoise pour M8	Distanciador para M8		
2	✓		B1338100	Supporto carter	Guard support	Verleitungsträger	Support carter	Soporte cárter		
3	✓		B1408300	Molla 1x14x600	1x14x600 spring	Feder 1x14x600	Ressort 1x14x600	Resorte 1x14x600		
4	✓		B1897000	Dado flangiato M12	M12 flanged nut	Flanschmutter M12	Écrou flangé M12	Tuerca rebordeado M12		
5	✓		B1955000	Prestola 6/15/0,25	6/15/0.25 lock ring	Sicherungsring 6/15/0,25	Anneau de blocage 6/15/0,25	Anillo sujeción 6/15/0,25		
6	✓		B2871000	Cilindro strangolo posteriore	Rear neck cylinder	Vordere Sperrvorrichtungszylinder	Cylindre étranglement postérieur	Cilindro dispositivo de bloqueo posterior		
7	✓		B4058000	Rosetta Fe 10,5x21 sferica	Fe 10.5x21 ball washer	Kugelscheibe Fe 10,5x21	Rondelle Fe 10,5x21 sphérique	Arandela Fe 10,5x21 esférico		
8	✓		B5815000	Raccordo V D.4	Y D.4 fitting	D.4 „Y“-Anschluss	Raccord Y D.4	Empalme Y D.4		
9	✓		B5864000	Molla T	T spring	T-Feder	Ressort T	Resorte T		
10	✓		B9837000	Protezione coda utensile	Tool tail guard	Werkzeugschutzgehäuse	Protection queue outil	Protección cola útil		
11	✓		B9874000	Rullino per utensile montaggio	Roller for assembling tool	Rolle für Montagewerkzeug	Rouleau pour outil montage	Rodillo para útil montaje		
12	✓		B9875000	Perno rullo utensile	Tool roller pin	Rollezapfen des Montagewerkzeugs	Pivot rouleau outil	Perno rodillo útil montaje		
13	✓		13830247	Tampone	Pad	Puffer	Tampon	Tampón		
14	✓		140315212	Perno	Pin	Zapfen	Pivot	Perno		
15	✓		140315391	Distanziale	Spacer	Abstandsstück	Entretoise	Distanciador		
16	✓		140315721	Tampone esagonale 40	40 hex-nut pad	Sechskantpuffer 40	Tampon hexagonal 40	Tampón hexágono 40		
17	✓		140440380	Rondella fermo torretta	Tower stopper washer	Scheibe für Turmsperre	Rondelle arrêt	Arandela de seguro torreta		
18	✓		140440390	Rosetta sferica	Ball washer	Kugelscheibe	Rondelle sphérique	Arandela esférica		
19	✓		140910700	Rullino strangolo	Neck roller	Sperrvorrichtungsrolle	Rouleau étranglement	Rodillo dispositivo de bloqueo		
20	✓		140910711	Cono strangolo	Neck cone	Sperrvorrichtungskegel	Cône étranglement	Cono dispositivo de bloqueo		
21	✓		203038	TE M8x25	TE M8x25 bolt	Schraube TE M8x25	Vis TE M8x25	Tornillo TE M8x25		
22	✓		203072	TE M12x30	TE M12x30 bolt	Schraube TE M12x30	Vis TE M12x30	Tornillo TE M12x30		
23	✓		203172	TE M8x16	TE M8x16 bolt	Schraube TE M8x16	Vis TE M8x16	Tornillo TE M8x16		
24	✓		206028	TCEI M8x10	TCEI M8x10 bolt	Schraube TCEI M8x10	Vis TCEI M8x10	Tornillo TCEI M8x10		
25	✓		206035	TCEI M8x20	TCEI M8x20 bolt	Schraube TCEI M8x20	Vis TCEI M8x20	Tornillo TCEI M8x20		
26	✓		206040	TCEI M8x30	TCEI M8x30 bolt	Schraube TCEI M8x30	Vis TCEI M8x30	Tornillo TCEI M8x30		
27	✓		206100	TCEI M6x60	TCEI M6x60 bolt	Schraube TCEI M6x60	Vis TCEI M6x60	Tornillo TCEI M6x60		
28	✓		206172	TCEI M8x16	TCEI M8x16 bolt	Schraube TCEI M8x16	Vis TCEI M8x16	Tornillo TCEI M8x16		
29	✓		209106	TPSEI M10x35	TSPEI M10x35 bolt	Schraube TSPEI M10x35	Vis TSPEI M10x35	Tornillo TSPEI M10x35		
30	✓		210040	STEI M8x30	STEI M8x30 bolt	Schraube STEI M8x30	Vis STEI M8x30	Tornillo STEI M8x30		
31	✓		210042	STEI piana M8x40	M8x40 STEI flat bolt	Flachschaube STEI M8x40	Vis STEI plane M8x40	Tornillo STEI plana M8x40		
32	✓		210069	STEI piana M12x16	M12x16 STEI flat bolt	Flachschaube STEI M12x16	Vis STEI plane M12x16	Tornillo STEI plana M12x16		

		<b>LISTA DEI COMPONENTI - LIST OF COMPONENTS - TEILELISTE</b> <b>LISTE DES PIÈCES DÉTACHÉES - LISTA DE PIEZAS</b>										KIT PALO POST KIT STANGENSET KIT POTEAU KIT PALO				<b>Pag. 53 di 235</b>																							
		<b>Tavola N°3D - Rev. 0</b>					<b>730097540</b>																																
ROT. HP441.201102	ROT. HP641.200938	ROT. HP641.201034	ROT. HP641.200891	ROT. HP641.200785	ROT. HP641.201003	ROT. HP641.201788	ROT. HP641.201072	ROT. HP641.201065	ROT. HP641.201997	ROT. HP643.200984	ROT. HP643.201681	ROT. HP643.201133	ROT. HP643.200983	RAV G7441.201140	RAV G7441.200969	RAV G7441.201119	RAV G7441.200716	RAV G7441.200877	RAV G7441.200921	RAV G7641.200945	RAV G7641.200006	RAV G7641.201041	RAV G7641.200907	RAV G7641.200689	RAV G7641.201010	RAV G7641.201089	RAV G7641.200761	RAV G7645.201232	RAV G7645.200914	RAV G7645.200990	RAV G8645.201249	SFA GA441.200976	SFA GA441.201126	SFA GA441.202000	SFA GA641.201027	SFA GA641.201096	SFA GA641.200952	SFA GA641.201058	SFA GA645.200600
<b>#</b>		<b>D.R</b>	<b>N</b>	<b>Descrizione</b>		<b>Description</b>		<b>Beschreibung</b>		<b>Description</b>		<b>Descripción</b>																											

33	✓		210317	STEI piana M12x12	M12x12 STEI flat bolt	Flachschraube STEI M12x12	Vis STEI plane M12x12	Tornillo STEI plana M12x12		
34	✓		210902	STEI M10x41,9	STEI M10x41.9 bolt	Schraube STEI M10x41,9	Vis STEI M10x41,9	Tornillo STEI M10x41,9		
35	✓		210904	STEI M12x42.1	STEI M12x42.1 bolt	Schraube STEI M12x42.1	Vis STEI M12x42.1	Tornillo STEI M12x42.1		
36	✓		224009	Dado esagonale medio M8	M8 med. hex nut	Mittlere Sechskantmutter M8	Écrou hexagonal moyen M8	Tuerca hexagonal medio M8		
37	✓		226009	Dado basso M8	M8 jam nut	Untere Mutter M8	Écrou bas M8	Tuerca baja M8		
38	✓		226011	Dado esagonale basso M10	M10 jam hex nut	Niedrige Sechskantmutter M10	Écrou hexagonal bas M10	Tuerca hexagonal baja M10		
39	✓		226024	Dado esagonale basso M18	M18 jam hex nut	Niedrige Sechskantmutter M18	Écrou hexagonal bas M18	Tuerca hexagonal baja M18		
40	✓		228010	Dado autobloccante M6	M6 self-locking nut	Selbstsichernde Mutter M6	Écrou auto-bloquant M6	Tuerca autoblocante M6		
41	✓		228012	Dado autobloccante M10	M10 self-locking nut	Selbstsichernde Mutter M10	Écrou auto-bloquant M10	Tuerca autoblocante M10		
42	✓		228310	Dado M10	M10 nut	Mutter M10	Écrou M10	Tuerca M10		
43	✓		234081	Spina cilindrica 10x60	10x60 cylindrical pin	Zylinderszapfen 10x60	Goupille cylindrique 10x60	Clavija cilíndrica 10x60		
44	✓		236006	Rondella piana 8,4	8.4 flat washer	Ebene Unterlagsscheibe 8,4	Rondelle plane 8,4	Arandela plana 8,4		
45	✓		237501	Rondella di spessore	Shim washer	Beilagscheibe	Rondelle d'épaisseur	Arandela de espesor		
46	✓		237511	Rondella di spessore	Shim washer	Beilagscheibe	Rondelle d'épaisseur	Arandela de espesor		
47	✓		238006	Rondella elastica 8,4	8.4 spring washer	Elastische Unterlagsscheibe 8,4	Rondelle elastique 8,4	Arandela elástica 8,4		
48	✓		243003	Seeger esterno 10	External clip ring 10	Externer Seeger 10	Anneau de retenue extérieur 10	Seeger externo 10		
49	✓		256066	TE M10x50	TE M10x50 bolt	Schraube TE M10x50	Vis TE M10x50	Tornillo TE M10x50		
50	✓		256186	TE M12x25	TE M12x25 bolt	Schraube TE M12x25	Vis TE M12x25	Tornillo TE M12x25		
51	✓		256902	TE M10x30	TE M10x30 bolt	Schraube M10x30	Vis TE M10x30	Tornillo TE M10x30		
52	✓		266167	TBEI M4x10	TBEI M4x10 bolt	Schraube TBEI M4x10	Vis TBEI M4x10	Tornillo TBEI M4x10		
53	✓		317006	Tube rilsan 6x4 nero	6x4 black rilsan hose	Rilsan Rohr 6x4 schwarz	Tuyau rilsan 6x4 noir	Tube rilsan 6x4 negro		
54	✓		317026	Tube rilsan 4x2,7 nero	4x2,7 black rilsan hose	Rilsan Rohr 4x2,7 schwarz	Tuyau rilsan 4x2,7 noir	Tube rilsan 4x2,7 negro		
55	✓		325191	Raccordo pneumatico Y-6	Y-6 pneumatic fitting	Pneumatischer Y-Anschluss 6	Raccord pneumatique Y-6	Empalme neumático Y-6		
56	✓		730012451	Tampone	Pad	Puffer	Tampon	Tampón		
57	✓		730012631	Strangolo	Neck	Sperrvorrichtung	Étranglement	Dispositivo de bloqueo		
58	✓		730014560	Rullino	Roller	Rolle	Rouleau	Rodillo		
59	✓		730015081	Trave orizzontale	Horizontal square	Horizontaler Träger	Poutre horizontale	Viga horizontal		
60	✓		730015110	Esagono CH.40	CH.40 hex-nut	Sechskant CH.40	Hexagone CH.40	Hexágono CH.40		
61	✓		730015120	Coperchio superiore	Upper cover	Obere Abdeckung	Couvercle supérieur	Tapa superior		
62	✓		730015170	Strangolo posteriore	Rear neck	Hintersperrvorrichtung	Étranglement arrière	Dispositivo de bloqueo posterior		
63	✓		730017010	Carter anteriore	Front guard	Vorderes Gehäuse	Carter antérieur	Cárter anterior		

#		D.R	N	Descrizione	Description	Beschreibung	Description	Descripción		
64	✓		730019102	Palo saldato	Welded post	Geschweißte Stange	Poteau soudé	Palo soldado		
65	✓		730019300	Utensile di montaggio	Toolhead	Montagewerkzeug	Outil de montage	Útil de montaje		
66	✓		730026180	Distanziale	Spacer	Abstandsstück	Entretoise	Distanciator		
67	✓		730091510	Corpo inferiore cilindro	Cylinder lower body	Unteres Zylindersgehäuse	Corps inférieur cylindre	Cuerpo inferior cilindro		
68	✓		730091520	Canna cilindro	Cylinder liner	Zylinderlaufbuchse	Chemise cylindre	Camisa cilindro		
69	✓		730091700	Maniglia completa	Complete handle	Kompletter Handgriff	Poignée complète	Manija completa		
70	✓		730093400	Cilindro strangolo D.80	D.80 neck cylinder	Sperrvorrichtungszylinder D.80	Cylindre étranglement D.80	Cilindro dispositivo de bloqueo D.80		
71	✓		730096950	Regolatore di pressione	Pressure regulator	Druckregler	Régulateur de pression	Regulador de presión		
72	✓		730096980	Strozzatore da 1.1	Flow control valve from 1.1	Durchflussregler ab 1.1	Soupape de détente depuis 1.1	Regulador de caudal de 1.1		
73	✓		730096990	Strozzatore da 0,85	Flow control valve from 0.85	Durchflussregler ab 0,85	Soupape de détente depuis 0,85	Regulador de caudal de 0,85		
74	✓		770012480	Protezione per testa utensile	Protection for tool head	Schutzgehäuse für Werkzeugskopf	Protection pour tête outil	Protección para cabeza útil		
75	✓		790011540	Distanziale per esagono	Spacer for hex-nut	Abstandsstück für Sechskant	Entretoise pour hexagone	Distanciator para hexágono		
76	✓		950001510	Molla	Spring	Feder	Ressort	Resorte		
77	✓		224011	Dado esagonale medio M10	M10 med. hex nut	Mittlere Sechskantmutter M10	Écrou hexagonal moyen M10	Tuerca hexagonal medio M10		

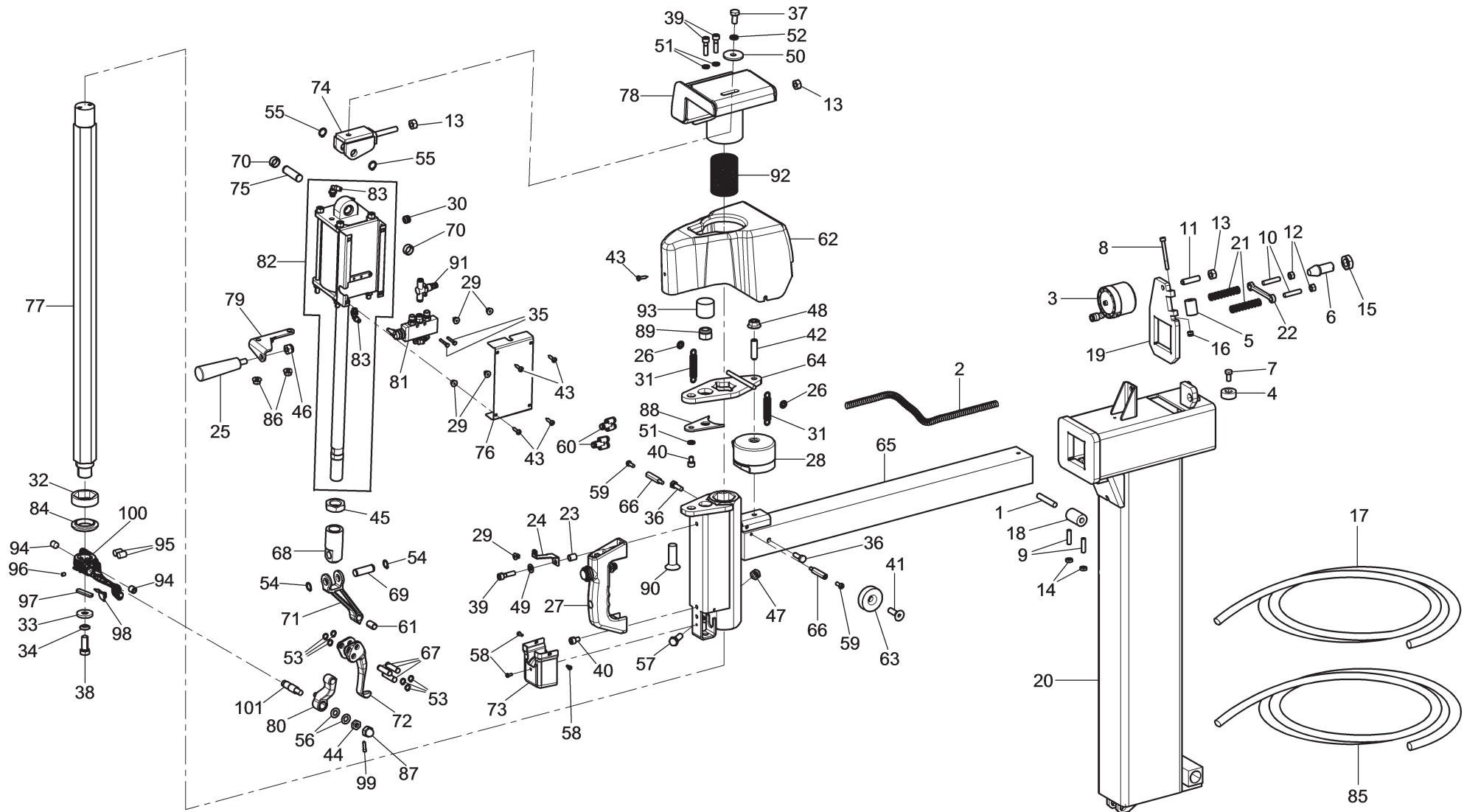

ROT. HP441.201102	ROT. HP641.200888	ROT. HP641.201034	ROT. HP641.200891	ROT. HP641.200785	ROT.HP641.201003 ROT.HP641.201788	ROT. HP641.201072	ROT. HP641.201065	ROT. HP641.201897	ROT.HP643.200894 ROT.HP643.201881	ROT. HP643.201133	ROT. HP643.200983	RAV. G7441.201140	RAV. G7441.200969	RAV. G7441.201119	RAV. G7441.200716	RAV. G7441.200877	RAV. G7441.200821	RAV. G7641.200945	RAV. G7641.200006	RAV. G7641.201041	RAV.G7641.200907 RAV.G7641.200683	RAV. G7641.201010	RAV. G7641.201089	RAV. G7641.200761	RAV. G7645.201232	RAV. G7645.200914	RAV. G7645.200990	RAV. G8645.201249	SFA. GA441.200976	SFA. GA441.201126	SFA. GA441.202000	SFA. GA641.201027	SFA. GA641.201096	SFA. GA641.200952	SFA. GA641.201058	SFA. GA645.200600
----------------------	----------------------	----------------------	----------------------	----------------------	--------------------------------------	----------------------	----------------------	----------------------	--------------------------------------	----------------------	----------------------	----------------------	----------------------	----------------------	----------------------	----------------------	----------------------	----------------------	----------------------	----------------------	--------------------------------------	----------------------	----------------------	----------------------	----------------------	----------------------	----------------------	----------------------	----------------------	----------------------	----------------------	----------------------	----------------------	----------------------	----------------------	----------------------







LISTA DEI COMPONENTI - LIST OF COMPONENTS - TEILELISTE  
LISTE DES PIÈCES DÉTACHÉES - LISTA DE PIEZAS

Tavola N°3E - Rev. 0

730098990



KIT PALO  
POST KIT  
STANGENSET  
KIT POTEAU  
KIT PALO

Pag. 55 di 235

		<b>LISTA DEI COMPONENTI - LIST OF COMPONENTS - TEILELISTE</b> <b>LISTE DES PIÈCES DÉTACHÉES - LISTA DE PIEZAS</b>										KIT PALO POST KIT STANGENSET KIT POTEAU KIT PALO					<b>Pag. 56 di 235</b>																						
		<b>Tavola N°3E - Rev. 0</b>					<b>730098990</b>																																
ROT. HP641.201102	ROT. HP641.200938	ROT. HP641.201034	ROT. HP641.200891	ROT. HP641.200785	ROT. HP641.201003	ROT. HP641.201788	ROT. HP641.201072	ROT. HP641.201065	ROT. HP641.201997	ROT. HP643.200984	ROT. HP643.201681	ROT. HP643.201133	ROT. HP643.200983	RAV. G7441.201140	RAV. G7441.200969	RAV. G7441.201119	RAV. G7441.200716	RAV. G7441.200877	RAV. G7441.200921	RAV. G7641.200945	RAV. G7641.200006	RAV. G7641.201041	RAV. G7641.200907	RAV. G7641.200689	RAV. G7641.201010	RAV. G7641.201089	RAV. G7641.200761	RAV. G7645.201232	RAV. G7645.200914	RAV. G7645.200990	RAV. G8645.201249	SFA. GA441.200976	SFA. GA441.201126	SFA. GA441.202000	SFA. GA641.201027	SFA. GA641.201096	SFA. GA641.200952	SFA. GA641.201058	SFA. GA645.200600
#		D.R	N	Descrizione		Description	Beschreibung	Description	Descripción																														

1	✓		234081	Spina cilindrica 10x60	10x60 cylindrical pin	Zylinderszapfen 10x60	Goupille cylindrique 10x60	Clavija cilíndrica 10x60		
2	✓		B1408300	Molla 1x14x600	1x14x600 spring	Feder 1x14x600	Ressort 1x14x600	Resorte 1x14x600		
3	✓		B2871000	Cilindro strangolo posteriore	Rear neck cylinder	Vordere Sperrvorrichtungszylinder	Cylindre étranglement postérieur	Cilindro dispositivo de bloqueo posterior		
4	✓		13830247	Tampone	Pad	Puffer	Tampon	Tampón		
5	✓		140910700	Rullino strangolo	Neck roller	Sperrvorrichtungsrolle	Rouleau étranglement	Rodillo dispositivo de bloqueo		
6	✓		140910711	Cono strangolo	Neck cone	Sperrvorrichtungskegel	Cône étranglement	Cono dispositivo de bloqueo		
7	✓		203172	TE M8x16	TE M8x16 bolt	Schraube TE M8x16	Vis TE M8x16	Tornillo TE M8x16		
8	✓		206100	TCEI M6x60	TCEI M6x60 bolt	Schraube TCEI M6x60	Vis TCEI M6x60	Tornillo TCEI M6x60		
9	✓		210040	STEI M8x30	STEI M8x30 bolt	Schraube STEI M8x30	Vis STEI M8x30	Tornillo STEI M8x30		
10	✓		210042	STEI piana M8x40	M8x40 STEI flat bolt	Flachschraube STEI M8x40	Vis STEI plane M8x40	Tornillo STEI plana M8x40		
11	✓		210902	STEI M10x41,9	STEI M10x41.9 bolt	Schraube STEI M10x41,9	Vis STEI M10x41,9	Tornillo STEI M10x41,9		
12	✓		224009	Dado esagonale medio M8	M8 med. hex nut	Mittlere Sechskantmutter M8	Écrou hexagonal moyen M8	Tuerca hexagonal medio M8		
13	✓		224011	Dado esagonale medio M10	M10 med. hex nut	Mittlere Sechskantmutter M10	Écrou hexagonal moyen M10	Tuerca hexagonal medio M10		
14	✓		226009	Dado basso M8	M8 jam nut	Untere Mutter M8	Écrou bas M8	Tuerca baja M8		
15	✓		226024	Dado esagonale basso M18	M18 jam hex nut	Niedrige Sechskantmutter M18	Écrou hexagonal bas M18	Tuerca hexagonal baja M18		
16	✓		228010	Dado autobloccante M6	M6 self-locking nut	Selbstsichernde Mutter M6	Écrou auto-bloquant M6	Tuerca autoblocante M6		
17	✓		317006	Tube rilsan 6x4 nero	6x4 black rilsan hose	Rilsan Rohr 6x4 schwarz	Tuyau rilsan 6x4 noir	Tube rilsan 6x4 negro		
18	✓		730014560	Rullino	Roller	Rolle	Rouleau	Rodillo		
19	✓		730015170	Strangolo posteriore	Rear neck	Hintersperrvorrichtung	Étranglement arrière	Dispositivo de bloqueo posterior		
20	✓		730019102	Palo saldato	Welded post	Geschweißte Stange	Poteau soudé	Palo soldado		
21	✓		950001510	Molla	Spring	Feder	Ressort	Resorte		
22	✓		730026180	Distanziale	Spacer	Abstandsstück	Entretoise	Distanciadador		
23	✓		B1337900	Distanziale per M8	Spacer for M8	Abstandsstück für M8	Entretoise pour M8	Distanciadador para M8		
24	✓		B1338100	Supporto carter	Guard support	Verleitungsträger	Support carter	Soporte cárter		
25	✓		B1416700	Impugnatura con perno	Handgrip with pin	Handgriff mit Zapfen	Poignée avec pivot	Empuñadura con perno		
26	✓		B1955000	Prestola 6/15/0,25	6/15/0.25 lock ring	Sicherungsring 6/15/0,25	Anneau de blocage 6/15/0,25	Anillo sujeción 6/15/0,25		
27	✓		B2859001	Maniglia completa C	C complete handle	Vollkommen Handgriff C	Poignée complète C	Manija completa C		
28	✓		730093400	Cilindro strangolo D.80	D.80 neck cylinder	Sperrvorrichtungszylinder D.80	Cylindre étranglement D.80	Cilindro dispositivo de bloqueo D.80		
29	✓		B3163000	Madrevite	Nut bolt	Leitspindel	Mère vis	Tornillo madre		
30	✓		B5527000	Passacavo	Hose clamp	Kabeldurchgang	Guide-câble	Pasacable		
31	✓		B5864000	Molla T	T spring	T-Feder	Ressort T	Resorte T		

VSG VEHICLE SERVICE GROUP a TORO company		LISTA DEI COMPONENTI - LIST OF COMPONENTS - TEILELISTE LISTE DES PIÈCES DÉTACHÉES - LISTA DE PIEZAS													KIT PALO POST KIT STANGENSET KIT POTEAU KIT PALO				Pag. 57 di 235	
Tavola N°3E - Rev. 0						730098990										▶		▶		
#		D.R	N	Descrizione	Description	Beschreibung	Description	Descripción	▶		▶									
32	✓		140315721	Tampone esagonale 40	40 hex-nut pad	Sechskantpuffer 40	Tampon hexagonal 40	Tampón hexágono 40												
33	✓		140440380	Rondella fermo torretta	Tower stopper washer	Scheibe für Turmsperre	Rondelle arrêt	Arandela de seguro torreta												
34	✓		140440390	Rosetta sferica	Ball washer	Kugelscheibe	Rondelle sphérique	Arandela esférica												
35	✓		201231	TE M4x25	TE M4x25 bolt	Schraube TE M4x25	Vis TE M4x25	Tornillo TE M4x25												
36	✓		203038	TE M8x25	TE M8x25 bolt	Schraube TE M8x25	Vis TE M8x25	Tornillo TE M8x25												
37	✓		203056	TE M10x20	TE M10x20 bolt	Schraube TE M10x20	Vis TE M10x20	Tornillo TE M10x20												
38	✓		203072	TE M12x30	TE M12x30 bolt	Schraube TE M12x30	Vis TE M12x30	Tornillo TE M12x30												
39	✓		206040	TCEI M8x30	TCEI M8x30 bolt	Schraube TCEI M8x30	Vis TCEI M8x30	Tornillo TCEI M8x30												
40	✓		206129	TCEI M8x12	TCEI M8x12 bolt	Schraube TCEI M8x12	Vis TCEI M8x12	Tornillo TCEI M8x12												
41	✓		209106	TPSEI M10x35	TSPEI M10x35 bolt	Schraube TSPEI M10x35	Vis TSPEI M10x35	Tornillo TSPEI M10x35												
42	✓		210904	STEI M12x42.1	STEI M12x42.1 bolt	Schraube STEI M12x42.1	Vis STEI M12x42.1	Tornillo STEI M12x42.1												
43	✓		220084	TCB 4,2x22	4.2x22 TCB bolt	Schraube TCB 4,2x22	Vis TCB4,2x22	Tornillo TCB 4,2x22												
44	✓		226011	Dado esagonale basso M10	M10 jam hex nut	Niedrige Sechskantmutter M10	Écrou hexagonal bas M10	Tuerca hexagonal baja M10												
45	✓		227023	Dado basso M24x1,5	M24x1.5 jam nut	Untere Mutter M24x1,5	Écrou bas M24x1,5	Tuerca baja M24x1,5												
46	✓		228012	Dado autobloccante M10	M10 self-locking nut	Selbstsichernde Mutter M10	Écrou auto-bloquant M10	Tuerca autoblocante M10												
47	✓		228310	Dado M10	M10 nut	Mutter M10	Écrou M10	Tuerca M10												
48	✓		B1897000	Dado flangiato M12	M12 flanged nut	Flanshmutter M12	Écrou flangé M12	Tuerca rebordeado M12												
49	✓		236006	Rondella piana 8,4	8.4 flat washer	Ebene Unterlagsscheibe 8,4	Rondelle plane 8,4	Arandela plana 8,4												
50	✓		237075	Rosetta 10,5x40x4	10.5x40x4 washer	Unterlegscheibe 10,5x40x4	Rondelle 10,5x40x4	Arandela 10,5x40x4												
51	✓		238006	Rondella elastica 8,4	8.4 spring washer	Elastische Unterlagsscheibe 8,4	Rondelle elastique 8,4	Arandela elástica 8,4												
52	✓		238007	Rondella elastica 10,5	10.5 spring washer	Elastische Unterlagsscheibe 10,5	Rondelle elastique 10,5	Arandela elástica 10,5												
53	✓		243003	Seeger esterno 10	External clip ring 10	Externer Seeger 10	Anneau de retenue extérieur 10	Seeger externo 10												
54	✓		243006	Seeger est.14 7435	External clip ring 14 7435	Externer Seeger 14 7435	Anneau de retenue extérieur 14 7435	Seeger externo 14 7435												
55	✓		243007	Seeger esterno 15	External clip ring 15	Externer Seeger 15	Anneau de retenue extérieur 15	Seeger externo 15												
56	✓		253011	Molla a tazza	Belleville washer	Becherfeder	Ressort à godet	Resorte de disco												
57	✓		256902	TE M10x30	TE M10x30 bolt	Schraube M10x30	Vis TE M10x30	Tornillo TE M10x30												
58	✓		266167	TBEI M4x10	TBEI M4x10 bolt	Schraube TBEI M4x10	Vis TBEI M4x10	Tornillo TBEI M4x10												
59	✓		266019	TBEI M6x16	TBEI M6x16 bolt	Schraube TBEI M6x16	Vis TBEI M6x16	Tornillo TBEI M6x16												
60	✓		325191	Raccordo pneumatico Y-6	Y-6 pneumatic fitting	Pneumatischer Y-Anschluss 6	Raccord pneumatique Y-6	Empalme neumático Y-6												
61	✓		630113	Boccola	Bushing	Büchse	Douille	Casquillo												

#		D.R	N	Descrizione	Description	Beschreibung	Description	Descripción		
---	---	-----	---	-------------	-------------	--------------	-------------	-------------	---	---

62	✓		730011901	Carter anteriore	Front guard	Vorderes Gehäuse	Carter antérieur	Cárter anterior		
63	✓		730012451	Tampone	Pad	Puffer	Tampon	Tampón		
64	✓		730012631	Strangolo	Neck	Sperrvorrichtung	Étranglement	Dispositivo de bloqueo		
65	✓		730015081	Trave orizzontale	Horizontal square	Horizontaler Träger	Poutre horizontale	Viga horizontal		
66	✓		730015160	Distanziale	Spacer	Abstandsstück	Entretoise	Distanciador		
67	✓		730016260	Perno D.10	D.10 pin	Zapfen D.10	Pivot D.10	Perno D.10		
68	✓		730018140	Terminale stelo	Rod terminal	Stangenterminal	Terminal tige	Terminal vástago		
69	✓		730018160	Perno	Pin	Zapfen	Pivot	Perno		
70	✓		730016710	Distanziale esterno	External spacer	Außenabstandsstück	Entretoise extérieur	Distanciador externo		
71	✓		730016721	Leva	Lever	Hebel	Levier	Palanca		
72	✓		730016733	Utensile di smontaggio	Disassembly tool	Demontagewerkzeug	Outil de démontage	Útil de desmontaje		
73	✓		730017010	Carter anteriore	Front guard	Vorderes Gehäuse	Carter antérieur	Cárter anterior		
74	✓		730017240	Insieme forcella	Fork assembly	Gabelsatz	Ensemble fourche	Conjunto horquilla		
75	✓		730017310	Perno D.15	D.15 pin	Zapfen D.15	Pivot D.15	Perno D.15		
76	✓		730021190	Carter esterno	External guard	Außengehäuse	Carter extérieur	Cárter externo		
77	✓		730017700	Esagono verticale	Vertical hex-nut	Senkrechtsechskant	Hexagone vertical	Hexágono vertical		
78	✓		730017711	Insieme cappuccio	Cap assembly	Haubensatz	Ensemble capuchon	Conjunto capuchón		
79	✓		730021210	Supporto maniglia	Handle support	Griffsträger	Support poignée	Soporte manija		
80	✓		730091921	Gruppo biella	Connecting rod assembly	Pleuelstangesatz	Ensemble bielle	Conjunto biela		
81	✓		730091960	Gruppo valvola Swing	Swing valve assembly	Swing-Ventilsatz	Ensemble soupape Swing	Conjunto válvula Swing		
82	✓		730093380	Cilindro D.90	D. 90 cylinder	Zylinder D.90	Cylindre D. 90	Cilindro D. 90		
83	✓		B9540000	Raccordo girevole 4-1/8	4-1/8 rotating fitting	Drehanschluss 4-1/8	Raccord pivotant 4-1/8	Empalme giratorio 4-1/8		
84	✓		790011540	Distanziale per esagono	Spacer for hex-nut	Abstandsstück für Sechskant	Entretoise pour hexagone	Distanciador para hexágono		
85	✓		317026	Tube rilsan 4x2,7 nero	4x2,7 black rilsan hose	Rilsan Rohr 4x2,7 schwarz	Tuyau rilsan 4x2,7 noir	Tube rilsan 4x2,7 negro		
86	✓		228501	Dado flangiato M8	M8 flanged nut	Flanschmutter M8	Écrou flangé M8	Tuerca rebordeado M8		
87	✓		229008	Dado cieco M10	M10 blind nut	Hutmutter M10	Écrou borgne M10	Tuerca ciega M10		
88	✓		730021250	Piastra di spessoramento	Shim plate	Beilagsplatte	Plaque d'épaisseur	Placa de espesor		
89	✓		228013	Dado autobloccante M16	M16 self-locking nut	Selbstsichernde Mutter M16	Écrou auto-bloquant M16	Tuerca autoblocante M16		
90	✓		B4028000	TSPEI M16x50	TSPEI M10x50 bolt	Schraube TSPEI M10x50	Vis TSPEI M10x50	Tornillo TSPEI M10x50		
91	✓		B1371800	Economizzatore	Economizer	Drosselsteller	Économiseur	Economizador		
92	✓		730018750	Molla	Spring	Feder	Ressort	Resorte		
93	✓		730025890	Distanziale di appoggio	Support spacer	Auflage-Abstandsstück	Entretoise d'appui	Distanciador de apoyo		
94	✓		210317	STEI piana M12x12	M12x12 STEI flat bolt	Flachschraube STEI M12x12	Vis STEI plane M12x12	Tornillo STEI plana M12x12		



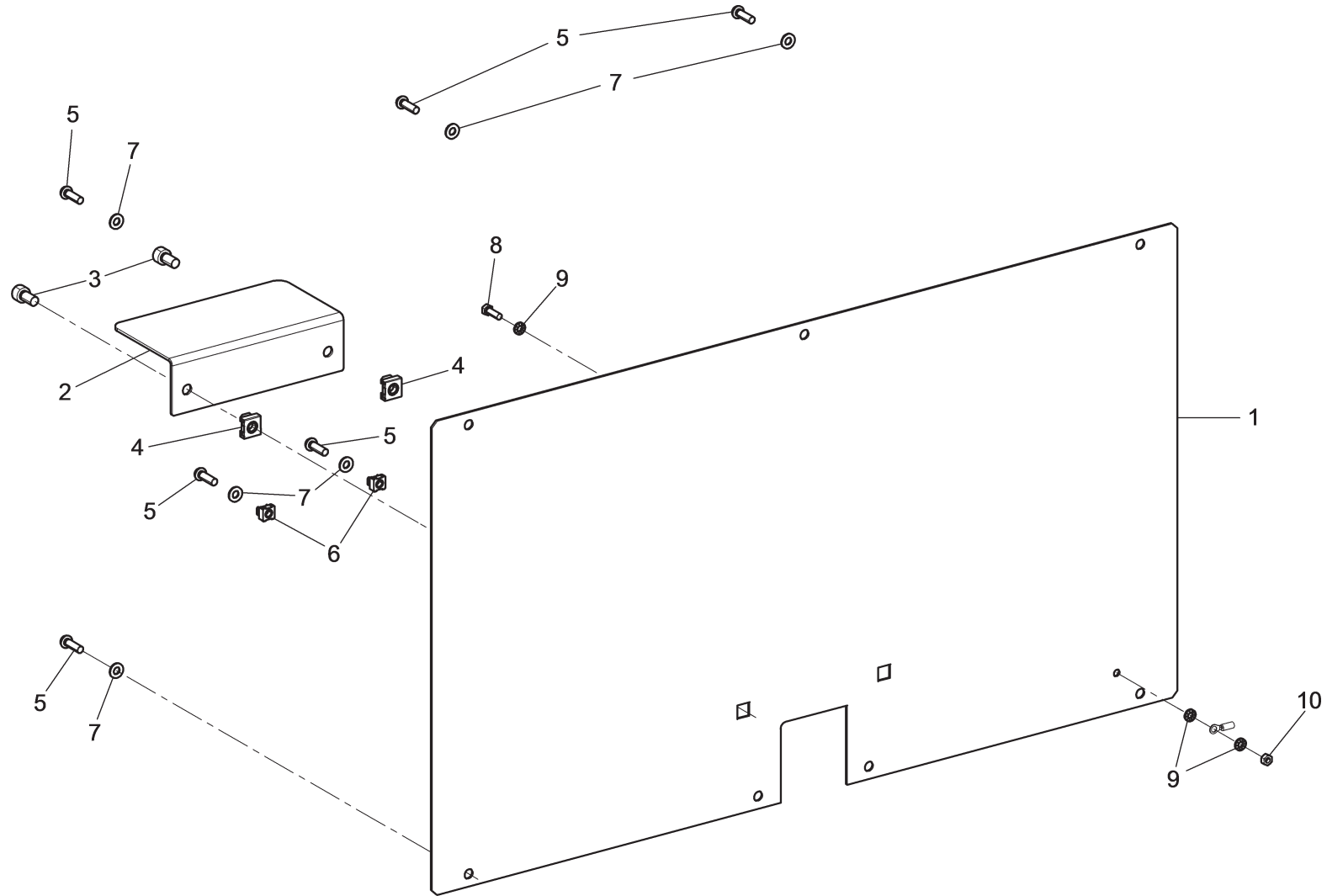

ROT. HP441.201102	ROT. HP641.200838	ROT. HP641.201034	ROT. HP641.200891	ROT. HP641.200785	ROT/HP641.201003	ROT/HP641.201788	ROT. HP641.201072	ROT. HP641.201065	ROT. HP641.201897	ROT/HP643.200894	ROT/HP643.201881	ROT. HP643.201133	ROT. HP643.200983	RAV. G7441.201140	RAV. G7441.200969	RAV. G7441.201119	RAV. G7441.200716	RAV. G7441.200877	RAV. G7441.200821	RAV. G7641.200945	RAV. G7641.200006	RAV. G7641.201041	RAV/G7641.200907	RAV/G7641.200683	RAV. G7641.201010	RAV. G7641.201089	RAV. G7641.200761	RAV. G7645.201232	RAV. G7645.200914	RAV. G7645.200990	RAV. G8645.201249	SPA. GA441.200976	SPA. GA441.201126	SPA. GA441.202000	SPA. GA641.201027	SPA. GA641.201096	SPA. GA641.200952	SPA. GA641.201058	SPA. GA645.200600						
•	•	•	•	•	•	•	•	•	•	•	•	•	•	•	•	•	•	•	•	•	•	•	•	•	•	•	•	•	•	•	•	•	•	•	•	•	•	•	•	•	•	•	•	•	•
		<b>LISTA DEI COMPONENTI - LIST OF COMPONENTS - TEILELISTE</b> <b>LISTE DES PIÈCES DÉTACHÉES - LISTA DE PIEZAS</b>																				<b>GRUPPO COFANO LATERALE</b> <b>LATERAL CASING ASSEMBLY</b> <b>SEITLICHER HAUBESATZ</b> <b>ENSEMBLE COFFRE LATÉRAL</b> <b>CONJUNTO CAPOT LATERAL</b>																							
		Tavola N°4A - Rev. 0										730094172										Pag. 60 di 235																							



LISTA DEI COMPONENTI - LIST OF COMPONENTS - TEILELISTE  
LISTE DES PIÈCES DÉTACHÉES - LISTA DE PIEZAS

GRUPPO COFANO LATERALE  
LATERAL CASING ASSEMBLY  
SEITLICHER HAUBESATZ  
ENSEMBLE COFFRE LATERAL  
CONJUNTO CAPOT LATERAL

Tavola N°4A - Rev. 0

730094172

#	D.R	N	Descrizione	Description	Beschreibung	Description	Descripción
1	✓	730023962	Cofano laterale	Lateral casing	Seitenhaube	Coffre latéral	Capot lateral
2	✓	B1137000	Protezione pedali nera	Pedal black guard	Schwarzes Pedalschutzgehäuse	Protection pédales noir	Protección pedales negra
3	✓	206172	TCEI M8x16	TCEI M8x16 bolt	Schraube TCEI M8x16	Vis TCEI M8x16	Tornillo TCEI M8x16
4	✓	228251	Dado in gabbia M8	M8 caged nut	Mutter im Käfig M8	Écrou en cage M8	Tuerca en jaula M8
5	✓	271021	TBEI M6x20	TBEI M6x20 bolt	Schraube TBEI M6x20	Vis TBEI M6x20	Tornillo TBEI M6x20
6	✓	228250	Dado in gabbia M6	M6 caged nut	Mutter im Käfig M6	Écrou en cage M6	Tuerca en jaula M6
7	✓	236004	Rondella piana 6,4	6.4 flat washer	Ebene Unterlagsscheibe 6,4	Rondelle plane 6,4	Arandela plana 6,4
8	✓	203208	TE M5x20	TE M5x20 bolt	Schraube TE M5x20	Vis TE M5x20	Tornillo TE M5x20
9	✓	239017	Rosetta	Washer	Unterlegscheibe	Rondelle	Arandela
10	✓	224005	Dado medio M5	M5 med nut	Mittlere Mutter M5	Écrou moyen M5	Tuerca media M5

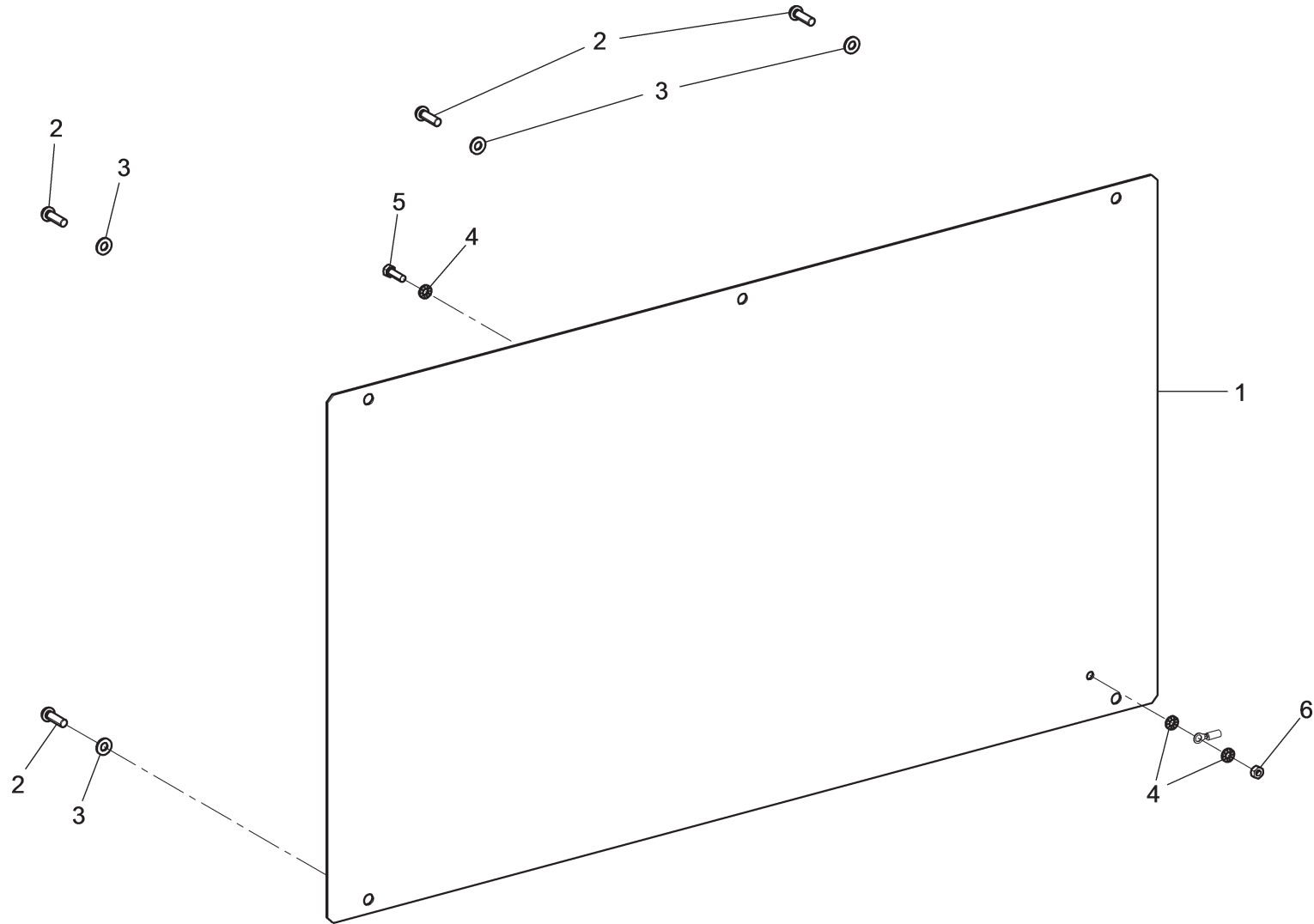

ROT. HP441.201102	ROT. HP641.200838	ROT. HF641.201034	ROT. HP641.200891	ROT. HF641.200785	ROT.HF641.201003 ROT.HF641.201788	ROT. HP641.201072	ROT. HP641.201065	ROT. HP641.201897	ROT.HF643.200884 ROT.HF643.201881	ROT. HP643.201133	ROT. HF643.200983	RAV. G7441.201140	RAV. G7441.200969	RAV. G7441.201119	RAV. G7441.200716	RAV. G7441.200877	RAV. G7441.200821	RAV. G7641.200945	RAV. G7641.200006	RAV. G7641.201041	RAV.G7641.200907 RAV.G7641.200683	RAV. G7641.201010	RAV. G7641.201089	RAV. G7641.200761	RAV. G7645.201232	RAV. G7645.200914	RAV. G7645.200890	RAV. G8645.201249	SPA. GA441.200976	SPA. GA441.201126	SPA. GA441.202000	SPA. GA641.201027	SPA. GA641.201096	SPA. GA641.200952	SPA. GA641.201058	SPA. GA645.200600					
												•	•											•																	
		<b>LISTA DEI COMPONENTI - LIST OF COMPONENTS - TEILELISTE</b> <b>LISTE DES PIÈCES DÉTACHÉES - LISTA DE PIEZAS</b>																			GRUPPO COFANO LATERALE LATERAL CASING ASSEMBLY SEITLICHER HAUBESATZ ENSEMBLE COFFRE LATÉRAL CONJUNTO CAPOT LATERAL																				
		<b>Tavola N°4B - Rev. 0</b>											<b>730094221</b>								<b>Pag. 62 di 235</b>																				



**LISTA DEI COMPONENTI - LIST OF COMPONENTS - TEILELISTE  
LISTE DES PIECES DETACHEES - LISTA DE PIEZAS**

GRUPPO COFANO LATERALE  
LATERAL CASING ASSEMBLY  
SEITLICHER HAUBESATZ  
ENSEMBLE COFFRE LATERAL  
CONJUNTO CAPOT LATERAL

**Tavola N°4B - Rev. 0**

**730094221**

ROT. HP441.201102	ROT. HP641.200938	ROT. HP641.201034	ROT. HP641.200891	ROT. HP641.200785	ROT.HP641.201003	ROT.HP641.201788	ROT. HP641.201072	ROT. HP641.201065	ROT. HP641.201997	ROT.HP643.200984	ROT.HP643.201681	ROT. HP643.201133	ROT. HP643.200983	RAV G7441.201140	RAV G7441.200969	RAV G7441.201119	RAV G7441.200716	RAV G7441.200877	RAV G7441.200921	RAV G7641.200945	RAV G7641.200006	RAV G7641.201041	RAV.G7641.200907	RAV.G7641.200689	RAV G7641.201010	RAV G7641.201089	RAV G7641.200761	RAV G7645.201232	RAV G7645.200914	RAV G7645.200990	RAV G8645.201249	SFA GA441.200976	SFA GA441.201126	SFA GA441.202000	SFA GA641.201027	SFA GA641.201096	SFA GA641.200952	SFA GA641.201058	SFA GA645.200600								
#		D.R	N	Descrizione	Description	Beschreibung	Description	Descripción																																							

1	✓		730023571	Cofano laterale	Lateral casing	Seitenhaube	Coffre latéral	Capot laterale																																															
2	✓		271021	TBEI M6x20	TBEI M6x20 bolt	Schraube TBEI M6x20	Vis TBEI M6x20	Tornillo TBEI M6x20																																															
3	✓		236004	Rondella piana 6,4	6.4 flat washer	Ebene Unterlagsscheibe 6,4	Rondelle plane 6,4	Arandela plana 6,4																																															
4	✓		239017	Rosetta	Washer	Unterlegscheibe	Rondelle	Arandela																																															
5	✓		203208	TE M5x20	TE M5x20 bolt	Schraube TE M5x20	Vis TE M5x20	Tornillo TE M5x20																																															
6	✓		224005	Dado medio M5	M5 med nut	Mittlere Mutter M5	Écrou moyen M5	Tuerca media M5																																															





LISTA DEI COMPONENTI - LIST OF COMPONENTS - TEILELISTE  
LISTE DES PIECES DETACHEES - LISTA DE PIEZAS

KIT BRACCIO STALLONATORE  
BEAD BREAKER ARM KIT  
ABDRÜCKERARMSET  
KIT BRAS DÉCOLLE-PNEUS  
KIT BRAZO DESTALONADOR

Tavola N°5A - Rev. 0

730098470

Table with 30 columns for part numbers and their variants (e.g., ROT. HP641.201102, RAV. G7441.200716, SPA. GA441.202000).

Row of small circular icons indicating specific part attributes or statuses.

Header row for the main parts list with columns: #, D.R., N, Descrizione, Description, Beschreibung, Description, Descripción, and arrows.

Main parts list table with 13 rows of data. Columns include item number, checkmarks, part numbers, and descriptions in multiple languages.

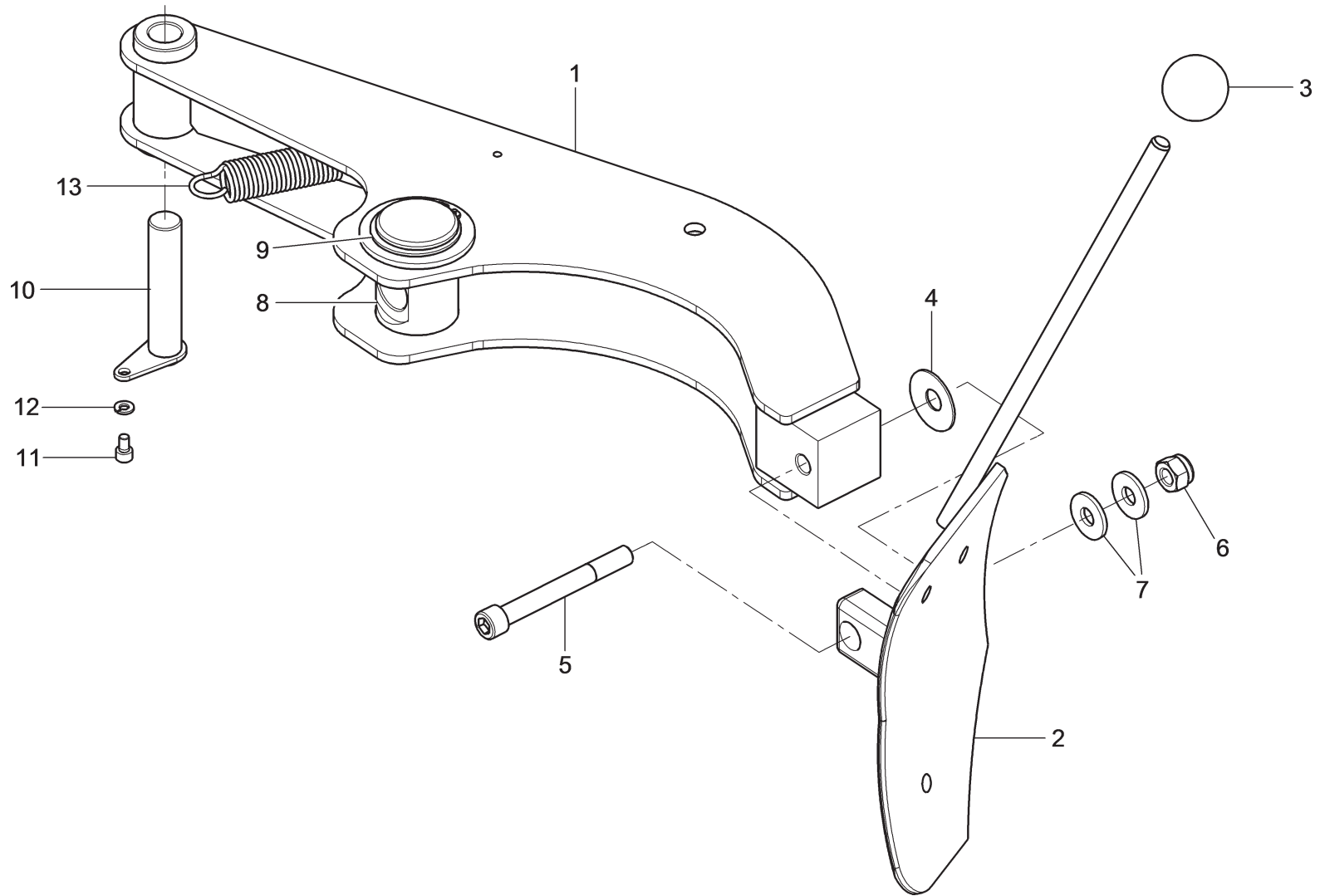

ROT. HP441.201102	ROT. HP641.200838	ROT. HF641.201034	ROT. HP641.200891	ROT. HF641.200785	ROT.HF641.201003 ROT.HF641.201788	ROT. HF641.201072	ROT. HF641.201065	ROT. HF641.201897	ROT.HF643.200684 ROT.HF643.201881	ROT. HF643.201133	ROT. HF643.200983	RAV. G7441.201140	RAV. G7441.200969	RAV. G7441.201119	RAV. G7441.200716	RAV. G7441.200877	RAV. G7441.200821	RAV. G7641.200945	RAV. G7641.200006	RAV. G7641.201041	RAV.G7641.200907 RAV.G7641.200683	RAV. G7641.201010	RAV. G7641.201089	RAV. G7641.200761	RAV. G7645.201232	RAV. G7645.200914	RAV. G7645.200990	RAV. G8645.201249	SFA. GA441.200976	SPA. GA441.201126	SFA. GA441.202000	SPA. GA641.201027	SPA. GA641.201096	SPA. GA641.200952	SPA. GA641.201058	SPA. GA645.200600		
	•	•	•	•	•	•	•	•	•	•								•	•	•	•	•	•	•	•	•	•	•	•	•	•	•	•	•	•	•	•	•
		<b>LISTA DEI COMPONENTI - LIST OF COMPONENTS - TEILELISTE</b> <b>LISTE DES PIÈCES DÉTACHÉES - LISTA DE PIEZAS</b>																			KIT BRACCIO STALLONATORE BEAD BREAKER ARM KIT ABDRÜCKERARMSET KIT BRAS DÉCOLLE-PNEUS KIT BRAZO DESTALONADOR																	
		Tavola N°5B - Rev. 0											730097740								Pag. 66 di 235																	

Tavola N°5B - Rev. 0

730097740

ROT. HP441.201102	ROT. HP641.200938	ROT. HP641.201034	ROT. HP641.200891	ROT. HP641.200785	ROT.HP641.201003 ROT.HP641.201788	ROT. HP641.201072	ROT. HP641.201065	ROT. HP641.201997	ROT.HP643.200984 ROT.HP643.201681	ROT. HP643.201133	ROT. HP643.200983	RAV. G7441.201140	RAV. G7441.200969	RAV. G7441.201119	RAV. G7441.200716	RAV. G7441.200877	RAV. G7441.200921	RAV. G7641.200945	RAV. G7641.200006	RAV. G7641.201041	RAV.G7641.200907 RAV.G7641.200689	RAV. G7641.201010	RAV. G7641.201089	RAV. G7641.200761	RAV. G7645.201232	RAV. G7645.200914	RAV. G7645.200990	RAV. G8645.201249	SFA. GA441.200976	SFA. GA441.201126	SFA. GA441.202000	SFA. GA641.201027	SFA. GA641.201096	SFA. GA641.200952	SFA. GA641.201058	SFA. GA645.200600
	•	•	•	•	•	•	•	•	•	•								•	•	•	•	•	•	•	•					•	•	•	•	•	•	•
#		D.R	N	Descrizione	Description	Beschreibung	Description	Descripción																												

1	✓		730011592	Braccio stallonatore	Bead breaker arm	Abdrückarm	Bras décolle-pneus	Brazo destalonador		
2	✓		B4064201	Paletta	Shovel	Schaufel	Palette	Paleta		
3	✓		903090	Pomolo sferico D.40	D.40 ball knob	Kugelhandgriff D.40	Poignée sphérique D.40	Pomo esferico D.40		
4	✓		253017	Molla tazza	Belleville washer	Becherfeder	Ressort godet	Resorte de disco		
5	✓		140925901	Vite per braccio stallonatore	Bolt for bead-breaker arm	Schraube für Abdrückerarm	Vis pour bras décolle-pneus	Tornillo para brazo destalonador		
6	✓		228006	Dado autobloccante M12	M12 self-locking nut	Selbstsichernde Mutter M12	Écrou auto-bloquant M12	Tuerca autoblocante M12		
7	✓		237069	Rondella piana	Flat washer	Ebene Unterlagsscheibe	Rondelle plane	Arandela plana		
8	✓		730019810	Perno fulcro	Pivot pin	Drehpunktzapfen	Pivot point d'appui	Perno fulcro		
9	✓		243022	Seeger esterno	External clip ring	Externer Seeger	Anneau de retenue extérieur	Seeger externo		
10	✓		140320430	Perno fulcro braccio	Arm pivot pin	Drehpunktzapfen des Arms	Pivot point d'appui bras	Perno fulcro braccio		
11	✓		206012	TCEI M6x10	TCEI M6x10 bolt	Schraube TCEI M6x10	Vis TCEI M6x10	Tornillo TCEI M6x10		
12	✓		238004	Rondella elastica 6,4	6.4 spring washer	Elastische Unterlagsscheibe 6,4	Rondelle elastique 6,4	Arandela elástica 6,4		
13	✓		950020060	Molla richiamo braccio	Arm return spring	Armfeder	Ressort retourne bras	Resorte vuelta brazo		





LISTA DEI COMPONENTI - LIST OF COMPONENTS - TEILELISTE  
LISTE DES PIÈCES DÉTACHÉES - LISTA DE PIEZAS

KIT BRACCIO STALLONATORE  
BEAD BREAKER ARM KIT  
ABDRÜCKERARMSET  
KIT BRAS DÉCOLLE-PNEUS  
KIT BRAZO DESTALONADOR

Tavola N°5C - Rev. 0

730097600

#	D.R	N	Descrizione	Description	Beschreibung	Description	Descripción		
1	✓		B1231800	Pomello registro pala	Vane adjusting knob	Schaufelreglerknopf	Poignée registre volet	Pomo registro pala	
2	✓		B1232100	Perno fulcro paletta	Shovel pivot pin	Drehpunktzapfen der Schaufel	Pivot point d'appui palette	Perno fulcro paleta	
3	✓		B4010601	Blocchetto snodo braccio	Arm joint block	Arm gelenklöckchen	Bloc joint bras	Bloque articulación brazo	
4	✓		B4064201	Paletta	Shovel	Schaufel	Palette	Paleta	
5	✓		140320430	Perno fulcro braccio	Arm pivot pin	Drehpunktzapfen des Arms	Pivot point d'appui bras	Perno fulcro brazo	
6	✓		140925901	Vite per braccio stallonatore	Bolt for bead-breaker arm	Schraube für Abdrückerarm	Vis pour bras décolle-pneus	Tornillo para brazo destalonador	
7	✓		206012	TCEI M6x10	TCEI M6x10 bolt	Schraube TCEI M6x10	Vis TCEI M6x10	Tornillo TCEI M6x10	
8	✓		228006	Dado autobloccante M12	M12 self-locking nut	Selbstsichernde Mutter M12	Écrou auto-bloquant M12	Tuerca autobloccante M12	
9	✓		228503	Dado autofrenante M12	M12 self-locking nut	Selbstverriegelungsmutter M12	Écrou auto-freinant M12	Tuerca autofrenante M12	
10	✓		237069	Rondella piana	Flat washer	Ebene Unterlagsscheibe	Rondelle plane	Arandela plana	
11	✓		238004	Rondella elastica 6,4	6.4 spring washer	Elastische Unterlagsscheibe 6,4	Rondelle elastique 6,4	Arandela elástica 6,4	
12	✓		243022	Seeger esterno	External clip ring	Externer Seeger	Anneau de retenue extérieur	Seeger esterno	
13	✓		730011571	Braccio stallonatore	Bead breaker arm	Abdrückarm	Bras décolle-pneus	Brazo destalonador	
14	✓		730019810	Perno fulcro	Pivot pin	Drehpunktzapfen	Pivot point d'appui	Perno fulcro	
15	✓		903090	Pomolo sferico D.40	D.40 ball knob	Kugelhandgriff D.40	Poignée sphérique D.40	Pomo esferico D.40	
16	✓		950020060	Molla richiamo braccio	Arm return spring	Armfeder	Ressort retourne bras	Resorte vuelta brazo	
17	✓		253017	Molla tazza	Belleville washer	Becherfeder	Ressort godet	Resorte de disco	



**Tavola N°6A - Rev. 0**

**730098480**

ROT. HP441.201102	ROT. HP641.200938	ROT. HP641.201034	ROT. HP641.200891	ROT. HP641.200785	ROT. HP641.201003	ROT. HP641.201788	ROT. HP641.201072	ROT. HP641.201065	ROT. HP641.201997	ROT. HP643.200984	ROT. HP643.201681	ROT. HP643.201133	ROT. HP643.200983	RAV. G7441.201140	RAV. G7441.200969	RAV. G7441.201119	RAV. G7441.200716	RAV. G7441.200877	RAV. G7441.200921	RAV. G7641.200945	RAV. G7641.200006	RAV. G7641.201041	RAV. G7641.200907	RAV. G7641.200889	RAV. G7641.201010	RAV. G7641.201089	RAV. G7641.200761	RAV. G7645.201232	RAV. G7645.200914	RAV. G7645.200990	RAV. G8645.201249	SFA. GA441.200976	SFA. GA441.201126	SFA. GA441.202000	SFA. GA641.201027	SFA. GA641.201096	SFA. GA641.200952	SFA. GA641.201058	SFA. GA645.200600		
●													●	●	●	●	●																●	●	●						

#		D.R	N	Descrizione	Description	Beschreibung	Description	Descripción		
1	✓		730091222	Kit cilindro stallonatore	Bead breaker cylinder kit	Abdrückzylinderset	Kit cylindre décolle-pneus	Kit cilindro destalonador		
2	✓		325107	Raccordo	Fitting	Anschluss	Raccord	Empalme		
3	✓		GU4090	Set guarnizione pistone	Piston gasket set	Kolbendichtungssatz	Ensemble joint piston	Conjunto junta pistón		
4	✓		140920361	Perno fulcro cilindro	Cylinder pivot pin	Drehpunktzapfen des Zylinders	Pivot point d'appui cylindre	Perno fulcro cilindro		
5	✓		203126	TE M6x8	TE M6x8 bolt	Schraube TE M6x8	Vis TE M6x8	Tornillo TE M6x8		
6	✓		237011	Rondella piana ø6x18	ø6x18 flat washer	Ebene Unterlagsscheibe ø6x18	Rondelle plane ø6x18	Arandela plana ø6x18		
7	✓		228015	Dado basso M18	M18 jam nut	Untere Mutter M18	Écrou bas M18	Tuerca baja M18		
8	✓		140320361	Ammortizzatore	Shock absorber	Dämpfer	Amortisseur	Amortiguador		

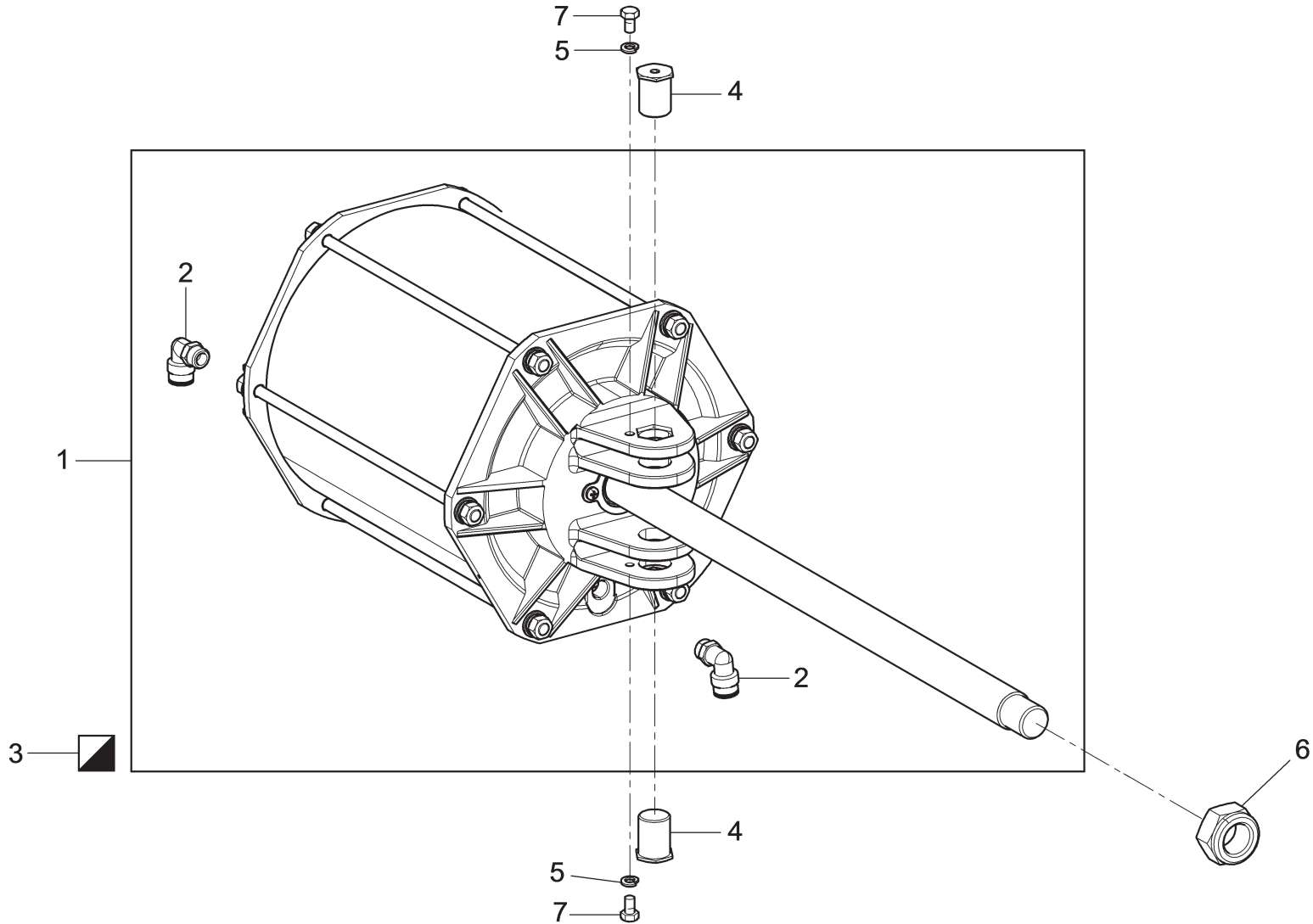

ROT. HP441.201102	•	ROT. HP641.200838	•	ROT. HF641.201034	•	ROT. HP641.200891	•	ROT. HP641.200785	•	ROT. HP641.201072	•	ROT. HP641.201065	•	ROT. HP641.201897	•	ROT. HP643.200884	•	ROT. HP643.201881	•	ROT. HP643.201133	•	ROT. HP643.200983	•	RAV. G7441.201140	•	RAV. G7441.200969	•	RAV. G7441.201119	•	RAV. G7441.200716	•	RAV. G7441.200877	•	RAV. G7441.200821	•	RAV. G7641.200945	•	RAV. G7641.200006	•	RAV. G7641.201041	•	RAV. G7641.200907	•	RAV. G7641.200683	•	RAV. G7641.201010	•	RAV. G7641.201089	•	RAV. G7641.200761	•	RAV. G7645.201232	•	RAV. G7645.200914	•	RAV. G7645.200990	•	RAV. G8645.201249	•	SFA. GA441.200876	•	SFA. GA441.201126	•	SFA. GA441.202000	•	SFA. GA641.201027	•	SFA. GA641.201096	•	SFA. GA641.200952	•	SFA. GA641.201058	•	SFA. GA645.200600	•
		<b>LISTA DEI COMPONENTI - LIST OF COMPONENTS - TEILELISTE</b> <b>LISTE DES PIÈCES DÉTACHÉES - LISTA DE PIEZAS</b>																								KIT CILINDRO STALLONATORE BEAD BREAKER CYLINDER KIT ABDRÜCKZYLINDERSET KIT CYLINDRE DÉCOLLE-PNEUS KIT CILINDRO DESTALONADOR												▶																																					
		<b>Tavola N°6B - Rev. 1</b>												<b>730098150</b>												<b>Pag. 72 di 235</b>																																																	



LISTA DEI COMPONENTI - LIST OF COMPONENTS - TEILELISTE  
LISTE DES PIÈCES DÉTACHÉES - LISTA DE PIEZAS

KIT CILINDRO STALLONATORE  
BEAD BREAKER CYLINDER KIT  
ABDRÜCKZYLINDERSET  
KIT CYLINDRE DÉCOLLE-PNEUS  
KIT CILINDRO DESTALONADOR

Tavola N°6B - Rev. 1

730098150

ROT. HP441.201102	ROT. HP641.200938	ROT. HP641.201034	ROT. HP641.200891	ROT. HP641.200785	ROT/HP641.201003	ROT/HP641.201788	ROT. HP641.201072	ROT. HP641.201065	ROT. HP641.201997	ROT/HP643.200984	ROT/HP643.201681	ROT. HP643.201133	ROT. HP643.200983	RAV. G7441.201140	RAV. G7441.200969	RAV. G7441.201119	RAV. G7441.200716	RAV. G7441.200877	RAV. G7441.200921	RAV. G7641.200945	RAV. G7641.200006	RAV. G7641.201041	RAV/G7641.200907	RAV/G7641.200689	RAV. G7641.201010	RAV. G7641.201089	RAV. G7641.200761	RAV. G7645.201232	RAV. G7645.200914	RAV. G7645.200990	RAV. G8645.201249	SFA. GA441.200976	SFA. GA441.201126	SFA. GA441.202000	SFA. GA641.201027	SFA. GA641.201096	SFA. GA641.200952	SFA. GA641.201058	SFA. GA645.200600
	•	•	•	•	•	•	•	•	•										•	•	•	•	•		•	•									•	•	•	•	

#		D.R	N	Descrizione	Description	Beschreibung	Description	Descripción	→	→
---	--	-----	---	-------------	-------------	--------------	-------------	-------------	---	---

1	✓		730095481	Kit cilindro stallonatore	Bead breaker cylinder kit	Abdrückzylinderset	Kit cylindre décolle-pneus	Kit cilindro destalonador		
2	✓		325107	Raccordo	Fitting	Anschluss	Raccord	Empalme		
3	✓		GU4090	Set guarnizione pistone	Piston gasket set	Kolbendichtungssatz	Ensemble joint piston	Conjunto junta pistón		
4	✓		140920361	Perno fulcro cilindro	Cylinder pivot pin	Drehpunktzapfen des Zylinders	Pivot point d'appui cylindre	Perno fulcro cilindro		
5	✓		237011	Rondella piana ø6x18	ø6x18 flat washer	Ebene Unterlagsscheibe ø6x18	Rondelle plane ø6x18	Arandela plana ø6x18		
6	✓		228041	Dado autobl. M22x1,5	M22x1,5 self-locking nut	Selbstsichernde Mutter M22x1,5	Écrou auto-bloquant M22x1,5	Tuerca autoblocante M22x1,5		
7	✓		203126	TE M6x8	TE M6x8 bolt	Schraube TE M6x8	Vis TE M6x8	Tornillo TE M6x8		

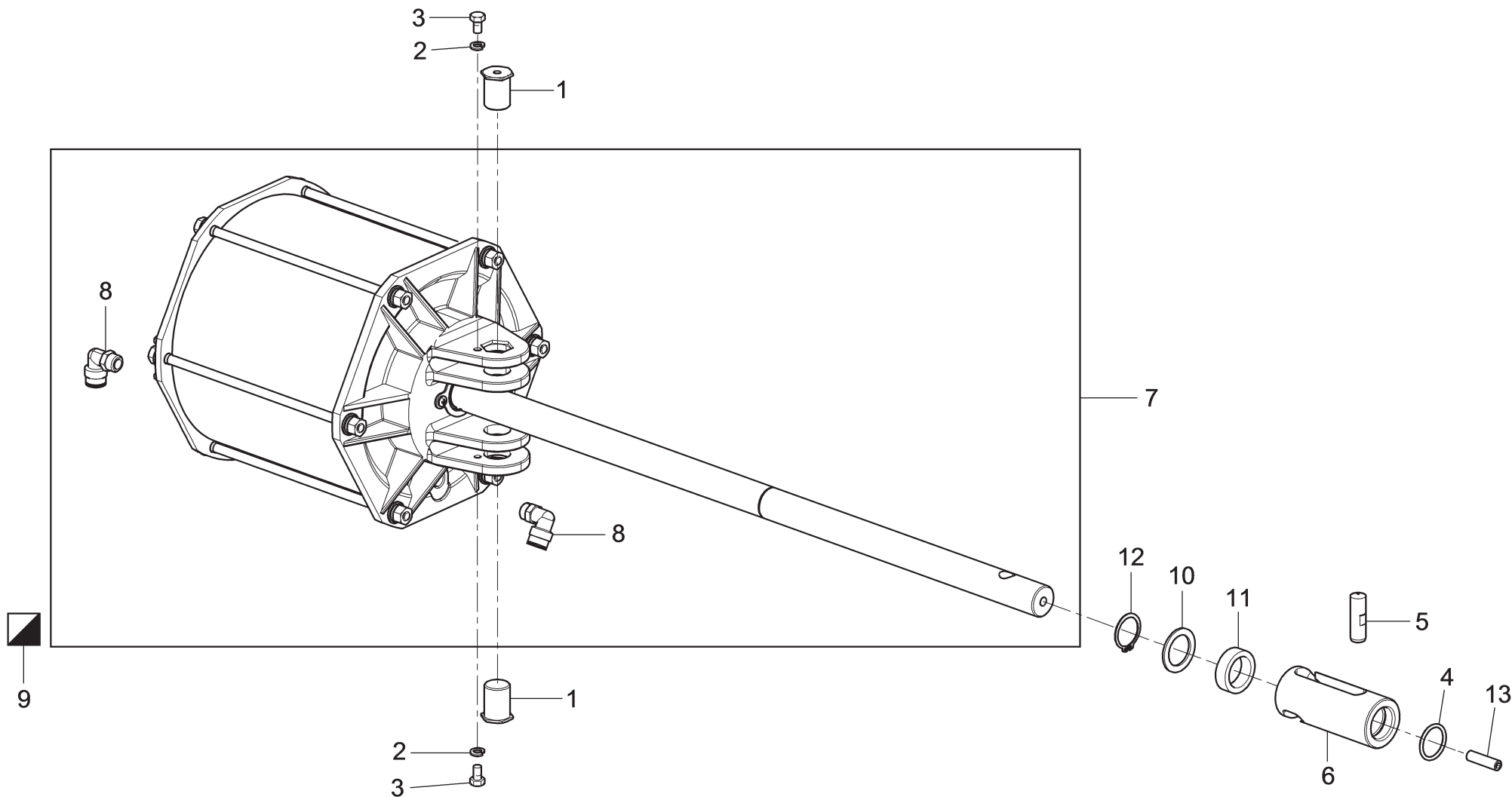

ROT. HP441.201102	ROT. HP641.200838	ROT. HP641.201034	ROT. HP641.200891	ROT. HP641.200785	ROT. HP641.201063	ROT. HP641.201788	ROT. HP641.201072	ROT. HP641.201065	ROT. HP641.201897	ROT. HP643.200684	ROT. HP643.201881	ROT. HP643.201133	ROT. HP643.200983	RAV. G7441.201140	RAV. G7441.200969	RAV. G7441.201119	RAV. G7441.200716	RAV. G7441.200877	RAV. G7441.200821	RAV. G7641.200945	RAV. G7641.200006	RAV. G7641.201041	RAV. G7641.200907	RAV. G7641.200683	RAV. G7641.201010	RAV. G7641.201089	RAV. G7641.200761	RAV. G7645.201232	RAV. G7645.200914	RAV. G7645.200890	RAV. G8645.201249	SFA. GA441.200876	SPA. GA441.201126	SFA. GA441.202000	SPA. GA641.201027	SPA. GA641.201096	SPA. GA641.200952	SPA. GA641.201058	SPA. GA645.200600					
										•	•	•																	•															
 VEHICLE SERVICE GROUP <small>an hilti company</small>														<b>LISTA DEI COMPONENTI - LIST OF COMPONENTS - TEILELISTE</b> <b>LISTE DES PIECES DETACHEES - LISTA DE PIEZAS</b>														KIT CILINDRO STALLONATORE BEAD BREAKER CYLINDER KIT ABDRÜCKZYLINDERSET KIT CYLINDRE DÉCOLLE-PNEUS KIT CILINDRO DESTALONADOR							▶ ▶									
														Tavola N°6C - Rev. 0							730097610														<b>Pag. 74 di 235</b>									



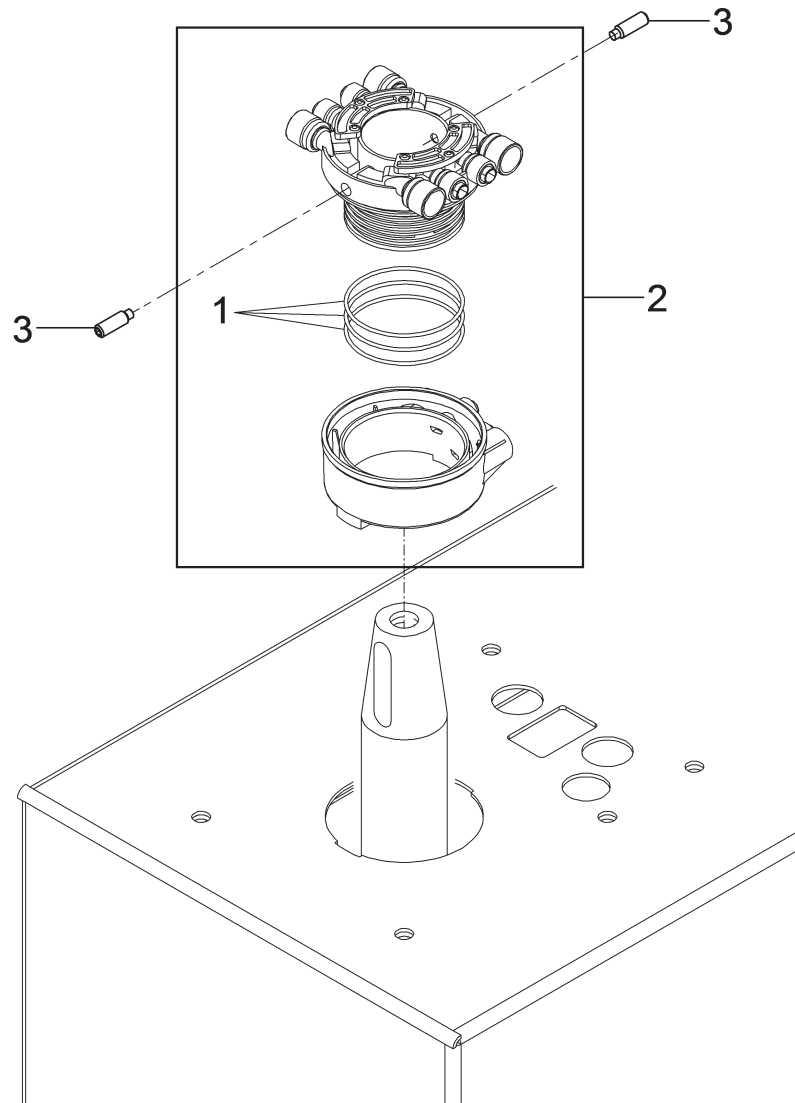

•	•	•	•	•	•		•	•	•	•	•	•	•	•	•	•	•	•	•	•	•	•	•	•	•	•	•	•	•	•	•	•	•	•	•	•	•
ROT. HP441.201102	ROT. HP641.200838	ROT. HF641.201034	ROT. HP641.200891	ROT. HP641.200785	ROT.HP641.201003 ROT.HP641.201788	ROT. HP641.201072	ROT. HP641.201065	ROT. HP641.201897	ROT.HP643.200894 ROT.HP643.201881	ROT. HP643.201133	ROT. HF643.200983	RAV. G7441.201140	RAV. G7441.200969	RAV. G7441.201119	RAV. G7441.200716	RAV. G7441.200877	RAV. G7441.200821	RAV. G7641.200945	RAV. G7641.200006	RAV. G7641.201041	RAV.G7641.200907 RAV.G7641.200683	RAV. G7641.201010	RAV. G7641.201089	RAV. G7641.200761	RAV. G7645.201232	RAV. G7645.200914	RAV. G7645.200890	RAV. G8645.201249	SFA. GA441.200976	SPA. GA441.201126	SFA. GA441.202000	SFA. GA641.201027	SFA. GA641.201096	SFA. GA641.200952	SFA. GA641.201058	SFA. GA645.200600	



**LISTA DEI COMPONENTI - LIST OF COMPONENTS - TEILELISTE  
LISTE DES PIÈCES DÉTACHÉES - LISTA DE PIEZAS**

**Tavola N°7A - Rev. 0**

**140390221**

INSIEME DISTRIBUTORE ROTANTE  
ROTATING DISTRIBUTOR ASSEMBLY  
ROTATIONSVERTEILERSATZ  
ENSEMBLE DISTRIBUTEUR ROTATIF  
CONJUNTO DISTRIBUIDOR GIRATORIO



**Pag. 76 di 235**



LISTA DEI COMPONENTI - LIST OF COMPONENTS - TEILELISTE  
LISTE DES PIÈCES DÉTACHÉES - LISTA DE PIEZAS

Tavola N°7A - Rev. 0

140390221



INSIEME DISTRIBUTORE ROTANTE  
ROTATING DISTRIBUTOR ASSEMBLY  
ROTATIONSVERTEILERSATZ  
ENSEMBLE DISTRIBUTEUR ROTATIF  
CONJUNTO DISTRIBUIDOR GIRATORIO

Pag. 77 di 235

ROT. HP441.201102	ROT. HP641.200938	ROT. HP641.201034	ROT. HP641.200891	ROT. HP641.200785	ROT. HP641.201003	ROT. HP641.201788	ROT. HP641.201072	ROT. HP641.201065	ROT. HP641.201997	ROT. HP643.200984	ROT. HP643.201681	ROT. HP643.201133	ROT. HP643.200983	RAV. G7441.201140	RAV. G7441.200969	RAV. G7441.201119	RAV. G7441.200716	RAV. G7441.200877	RAV. G7441.200921	RAV. G7641.200945	RAV. G7641.200006	RAV. G7641.201041	RAV. G7641.200807	RAV. G7641.200689	RAV. G7641.201010	RAV. G7641.201089	RAV. G7641.200761	RAV. G7645.201232	RAV. G7645.200914	RAV. G7645.200990	RAV. G8645.201249	SFA. GA441.200976	SFA. GA441.201126	SFA. GA441.202000	SFA. GA641.201027	SFA. GA641.201096	SFA. GA641.200952	SFA. GA641.201058	SFA. GA645.200600		
•	•		•	•	•			•	•	•			•	•	•	•	•		•	•	•		•	•		•						•		•		•			•		
#		D.R	N	Descrizione		Description		Beschreibung		Description		Descripción																													

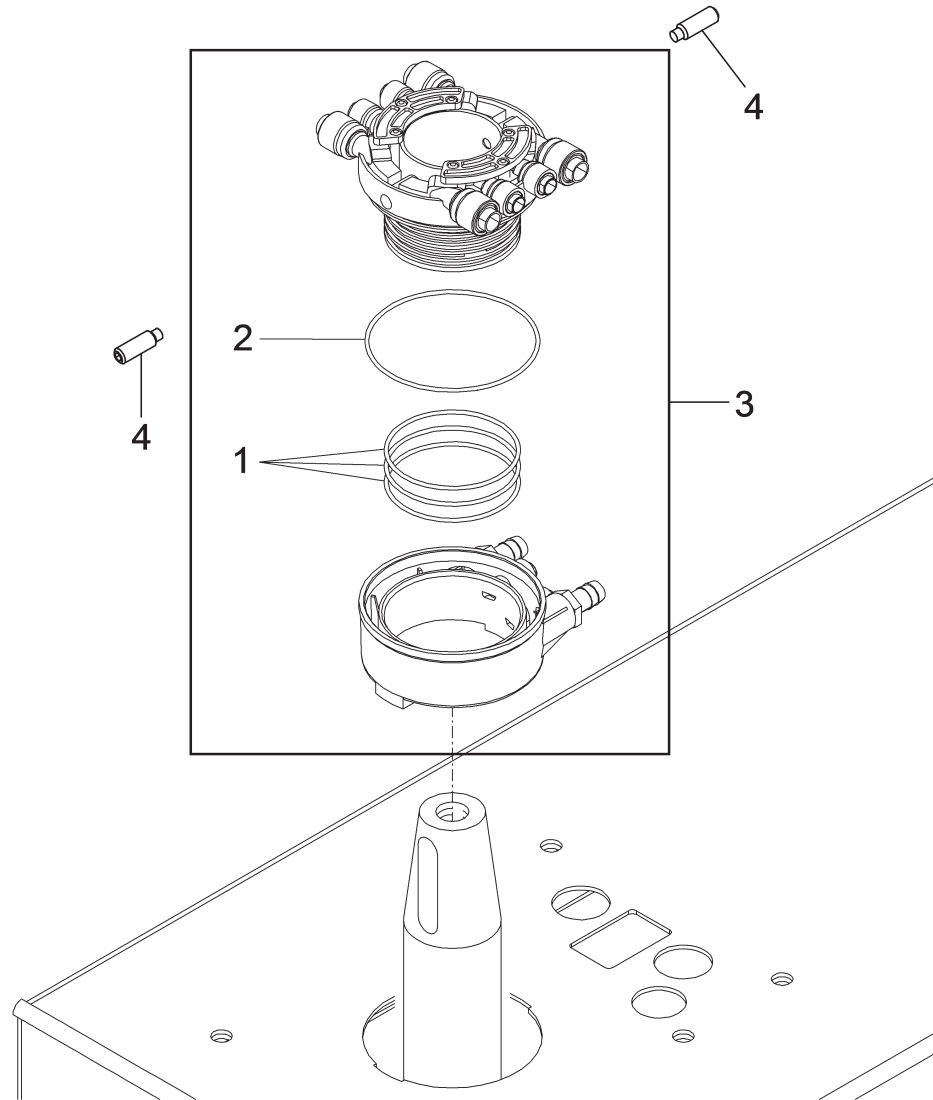
1	✓		E7093000	Guarnizione OR 2,62 x 64,77	2.62 x 64.77 O-ring	OR Dichtung 2,62 x 64,77	Joint OR 2,62 x 64,77	Junta OR 2,62 x 64,77								
2	✓		E7096000	Raccordo girevole	Rotating fitting	Drehanschluss	Raccord pivotant	Empalme giratorio								
3	✓		211035	STEI cilindrica M8x20	STEI M8x20 bolt	Schraube STEI M8x20	Vis STEI cylindrique M8x20	Tornillo STEI M8x20								



ROT. HP441.201102	ROT. HP641.200838	ROT. HF641.201034	ROT. HP641.200891	ROT. HF641.200785	ROT.HP641.201063 ROT.HP641.201788	ROT. HF641.201072	ROT. HF641.201065	ROT. HF641.201897	ROT.HP643.200884 ROT.HP643.201881	ROT. HP643.201133	ROT. HF643.200983	RAV. G7441.201140	RAV. G7441.200969	RAV. G7441.201119	RAV. G7441.200716	RAV. G7441.200877	RAV. G7441.200821	RAV. G7641.200945	RAV. G7641.200006	RAV. G7641.201041	RAV.G7641.200907 RAV.G7641.200683	RAV. G7641.201010	RAV. G7641.201089	RAV. G7641.200761	RAV. G7645.201232	RAV. G7645.200914	RAV. G7645.200990	RAV. G8645.201249	SFA. GA441.200976	SPA. GA441.201126	SFA. GA441.202000	SPA. GA641.201027	SFA. GA641.201096	SPA. GA641.200952	SPA. GA641.201058	SPA. GA645.200600			
		•				•				•						•				•			•				•				•				•				
		<b>LISTA DEI COMPONENTI - LIST OF COMPONENTS - TEILELISTE</b> <b>LISTE DES PIÈCES DÉTACHÉES - LISTA DE PIEZAS</b>																			INSIEME DISTRIBUTORE ROTANTE ROTATING DISTRIBUTOR ASSEMBLY ROTATIONSVERTEILERSATZ ENSEMBLE DISTRIBUTEUR ROTATIF CONJUNTO DISTRIBUIDOR GIRATORIO						 												
		Tavola N°7B - Rev. 0									140302093									<b>Pag. 78 di 235</b>																			



**LISTA DEI COMPONENTI - LIST OF COMPONENTS - TEILELISTE**  
**LISTE DES PIECES DETACHEES - LISTA DE PIEZAS**

INSIEME DISTRIBUTORE ROTANTE  
 ROTATING DISTRIBUTOR ASSEMBLY  
 ROTATIONSVERTEILERSATZ  
 ENSEMBLE DISTRIBUTEUR ROTATIF  
 CONJUNTO DISTRIBUIDOR GIRATORIO

**Pag. 79 di 235**







**Tavola N°7B - Rev. 0**

**140302093**

ROT. HP441.201102	ROT. HP641.200938	ROT. HP641.201034	ROT. HP641.200891	ROT. HP641.200785	ROT. HP641.201003	ROT. HP641.201788	ROT. HP641.201072	ROT. HP641.201065	ROT. HP641.201997	ROT. HP643.200984	ROT. HP643.201081	ROT. HP643.201133	ROT. HP643.200983	RAV. G7441.201140	RAV. G7441.200969	RAV. G7441.201119	RAV. G7441.200716	RAV. G7441.200877	RAV. G7441.200921	RAV. G7641.200945	RAV. G7641.200006	RAV. G7641.201041	RAV. G7641.200907	RAV. G7641.200889	RAV. G7641.201010	RAV. G7641.201089	RAV. G7641.200761	RAV. G7645.201232	RAV. G7645.200914	RAV. G7645.200990	RAV. G8645.201249	SFA. GA441.200976	SFA. GA441.201126	SFA. GA441.202000	SFA. GA641.201027	SFA. GA641.201096	SFA. GA641.200952	SFA. GA641.201058	SFA. GA645.200600							
		•					•											•							•		•							•					•							
#		D.R	N	Descrizione	Description	Beschreibung	Description	Descripción																																						

1	✓		B7093000	Guarnizione OR 2,62 x 64,77	2.62 x 64.77 O-ring	OR Dichtung 2,62 x 64,77	Joint OR 2,62 x 64,77	Junta OR 2,62 x 64,77																																																	
2	✓		B7092000	Guarnizione OR	O-ring	OR Dichtung	Joint OR	Junta OR																																																	
3	✓		B7095000	Raccordo girevole FI	FI rotating fitting	Drehanschluss FI	Raccord pivotant FI	Empalme giratorio FI																																																	
4	✓		211035	STEI cilindrica M8x20	STEI M8x20 bolt	Schraube STEI M8x20	Vis STEI cylindrique M8x20	Tornillo STEI M8x20																																																	





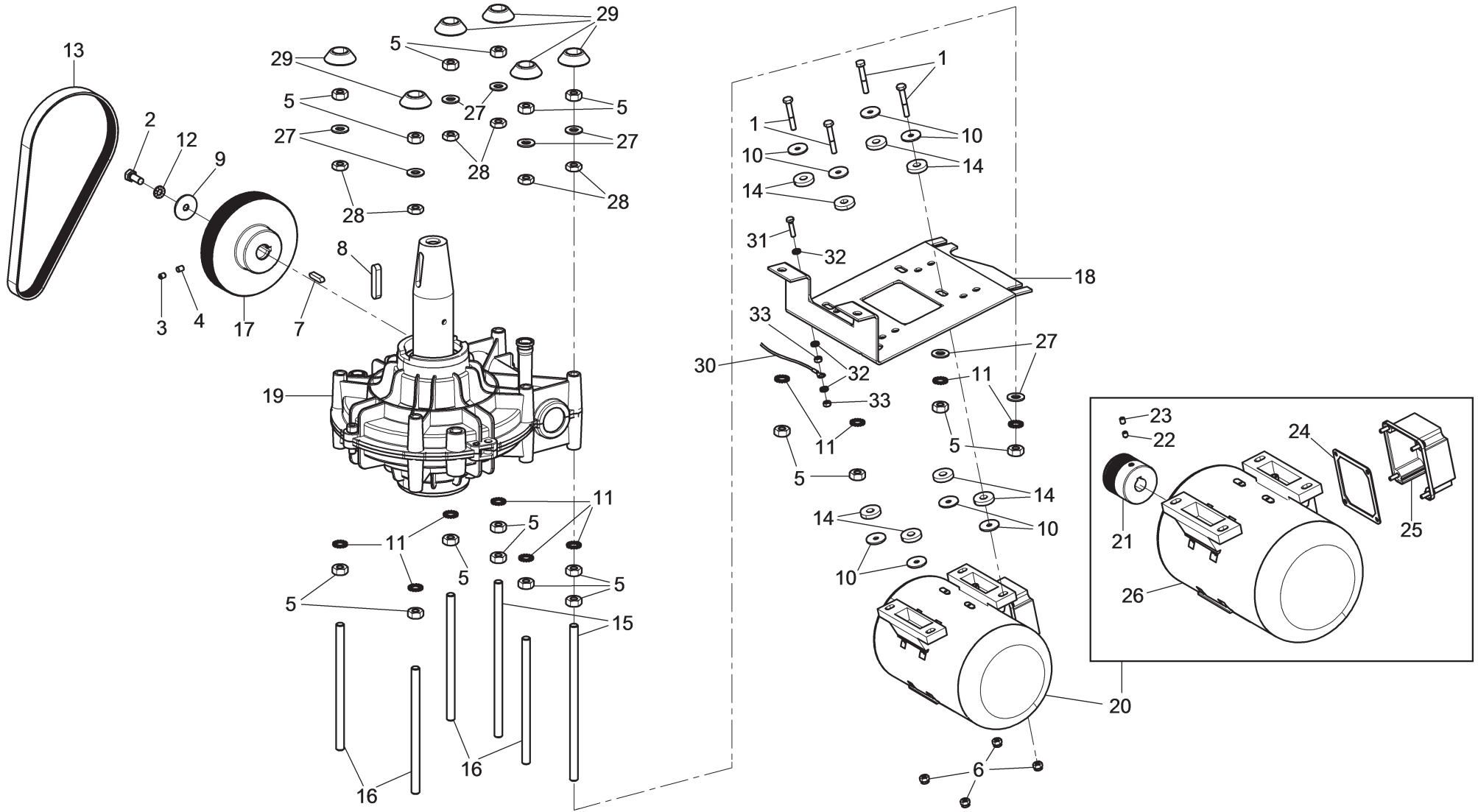

		<b>LISTA DEI COMPONENTI - LIST OF COMPONENTS - TEILELISTE</b> <b>LISTE DES PIÈCES DÉTACHÉES - LISTA DE PIEZAS</b>										KIT MOTORIDUTTORE GEARMOTOR KIT UNTERSETZERSET KIT MOTOREDUCTEUR KIT MOTORREDUCTOR										<b>Pag. 81 di 235</b>																			
		<b>Tavola N°8A - Rev. 1</b>					<b>730098290</b>																																		
ROT. HP441.201102	ROT. HP641.200938	ROT. HP641.201034	ROT. HP641.200891	ROT. HP641.200785	ROT. HP641.201003	ROT. HP641.201788	ROT. HP641.201072	ROT. HP641.201065	ROT. HP641.201997	ROT. HP643.200984	ROT. HP643.201681	ROT. HP643.201133	ROT. HP643.200983	RAV. G7441.201140	RAV. G7441.200969	RAV. G7441.201119	RAV. G7441.200716	RAV. G7441.200877	RAV. G7441.200821	RAV. G7641.200945	RAV. G7641.200006	RAV. G7641.201041	RAV. G7641.200907	RAV. G7641.200689	RAV. G7641.201010	RAV. G7641.201089	RAV. G7641.200761	RAV. G7645.201232	RAV. G7645.200914	RAV. G7645.200990	RAV. G8645.201249	SFA. GA441.200976	SFA. GA441.201126	SFA. GA441.202000	SFA. GAG41.201027	SFA. GAG41.201096	SFA. GAG41.200952	SFA. GAG41.201058	SFA. GAG45.200600		
●				●		●	●	●						●	●	●	●	●	●				●	●	●	●							●	●	●	●					
#		D.R	N	Descrizione	Description	Beschreibung	Description	Descripción																																	

1	✓		730023650	Tirante per riduttore M10x180	M10x180 tie rod for reduction gear	Spannstange für Untersetzer M10x180	Tirant pour réducteur M10x180	Jalador para reductor M10x180				
2	✓		14030532	Tirante per riduttore M10x170	M10x170 tie rod for reduction gear	Spannstange für Untersetzer M10x170	Tirant pour réducteur M10x170	Jalador para reductor M10x170				
3	✓		140305521	Insieme riduttore	Reduction gear assembly	Untersetzerssatz	Ensemble réducteur	Conjunto reductor				
4	✓		201042	TE M8x40	TE M8x40 bolt	Schraube TE M8x40	Vis TE M8x40	Tornillo TE M8x40				
5	✓		203035	TE M8x20	TE M8x20 bolt	Schraube TE M8x20	Vis TE M8x20	Tornillo TE M8x20				
6	✓		210126	STEI M6x8	STEI M6x8 bolt	Schraube STEI M6x8	Vis STEI M6x8	Tornillo STEI M6x8				
7	✓		213126	STEI coppa M6x8	STEI M6x8 cup bolt	Topfschraube STEI M6x8	Vis STEI M6x8 flasque	Tornillo STEI M6x8 copa				
8	✓		224011	Dado esagonale medio M10	M10 med. hex nut	Mittlere Sechskantmutter M10	Écrou hexagonal moyen M10	Tuerca hexagonal medio M10				
9	✓		226011	Dado esagonale basso M10	M10 jam hex nut	Niedrige Sechskantmutter M10	Écrou hexagonal bas M10	Tuerca hexagonal baja M10				
10	✓		228011	Dado autobloccante M8	M8 self-locking nut	Selbstsichernde Mutter M8	Écrou auto-bloquant M8	Tuerca autobloccante M8				
11	✓		231003	Chiavetta 6x6x25	6x6x25 wrench	Schlüssel 6x6x25	Clé 6x6x25	Llave 6x6x25				
12	✓		231068	Chiavetta 10x8x45	10x8x45 wrench	Schlüssel 10x8x45	Clé 10x8x45	Llave 10x8x45				
13	✓		237072	Rosetta D.8,4x22x2,5	D.8,4x22x2,5 washer	Unterlegscheibe D.8,4x22x2,5	Rondelle D.8,4x22x2,5	Arandela D.8,4x22x2,5				
14	✓		239041	Rondella dentata 10,5	10.5 toothed washer	Zahnunterlagscheibe 10,5	Rondelle dentée 10,5	Arandela dentada 10,5				
15	✓		239023	Rondella dentata 8,4	8.4 toothed washer	Zahnunterlagscheibe 8,4	Rondelle dentée 8,4	Arandela dentada 8,4				
16	✓		412081	Rondella gomma	Rubber washer	Gummischeibe	Rondelle en caoutchouc	Arandela en goma				
17	✓		412103	Cinghia	Belt	Riemen	Courroie	Correa				
18	✓		730012420	Puleggia D.132	D.132 pulley	Riemenscheibe D.132	Poulie D.132	Polea D.132				
19	✓		730020220	Puleggia D.71	D.71 pulley	Riemenscheibe D.71	Poulie D.71	Polea D.71				
20	✓		730023581	Lama supporto motore	Motor support blade	Motorstützklinge	Lame support moteur	Cuchilla soporte motor				
21	✓		900001871	Motore elettrico	Electric motor	Elektromotor	Moteur électrique	Motor eléctrico				
22	✓		236007	Rondella piana 10,5x21x2	Fe 10,5x21x2 washer	Ebene Unterlagsscheibe 10,5x21x2	Rondelle Fe 10,5x21x2	Arandela Fe 10,5x21x2				
23	✓		730015400	Tappo protezione	Protection plug	Schutzstöpsel	Bouchon protection	Tapón protección				
24	✓		790065110	Cavo di terra	Ground cable	Erdkabel	Câble de masse	Cable tierra				
25	✓		203208	TE M5x20	TE M5x20 bolt	Schraube TE M5x20	Vis TE M5x20	Tornillo TE M5x20				
26	✓		239017	Rosetta	Washer	Unterlegscheibe	Rondelle	Arandela				
27	✓		224005	Dado medio M5	M5 med nut	Mittlere Mutter M5	Écrou moyen M5	Tuerca media M5				
28	✓		237037	Rondella piana tranciante 8x32x2,5	8x32x2,5 flat washer	Ebene Schneidscheibe 8x32x2,5	Rondelle plane 8x32x2,5	Arandela plana 8x32x2,5				



ROT. HP441.201102	ROT. HP641.200888	ROT. HP641.201034	ROT. HP641.200891	ROT. HP641.200785	ROT.HP641.201003 ROT.HP641.201788	ROT. HP641.201072	ROT. HP641.201065	ROT. HP641.201897	ROT.HP643.200884 ROT.HP643.201881	ROT. HP643.201133	ROT. HP643.200983	RAV. G7441.201140	RAV. G7441.200969	RAV. G7441.201119	RAV. G7441.200716	RAV. G7441.200877	RAV. G7441.200821	RAV. G7641.200945	RAV. G7641.200006	RAV. G7641.201041	RAV.G7641.200907 RAV.G7641.200683	RAV. G7641.201010	RAV. G7641.201089	RAV. G7641.200761	RAV. G7645.201232	RAV. G7645.200914	RAV. G7645.200990	RAV. G8645.201249	SFA. GA441.200976	SFA. GA441.201126	SFA. GA441.202000	SFA. GA641.201027	SFA. GA641.201096	SFA. GA641.200952	SFA. GA641.201058	SFA. GA645.200600				
	●	●	●	●														●	●	●	●			●													●	●		
		<b>LISTA DEI COMPONENTI - LIST OF COMPONENTS - TEILELISTE</b> <b>LISTE DES PIÈCES DÉTACHÉES - LISTA DE PIEZAS</b>																			KIT MOTORIDUTTORE GEARMOTOR KIT UNTERSATZERSSET KIT MOTOREDUCTEUR KIT MOTORREDUCTOR						▶ ▶													
		<b>Tavola N°8B - Rev. 0</b>												<b>730098140</b>						<b>Pag. 82 di 235</b>																				

			<b>LISTA DEI COMPONENTI - LIST OF COMPONENTS - TEILELISTE</b> <b>LISTE DES PIÈCES DÉTACHÉES - LISTA DE PIEZAS</b>										KIT MOTORIDUTTORE GEARMOTOR KIT UNTERSETZERSET KIT MOTOREDUCTEUR KIT MOTORREDUCTOR						<b>Pag. 83 di 235</b>																					
			<b>Tavola N°8B - Rev. 0</b>					<b>730098140</b>					 																											
ROT. HP441.201102	ROT. HP641.200938	ROT. HP641.201034	ROT. HP641.200891	ROT. HP641.200785	ROT. HP641.201003	ROT. HP641.201788	ROT. HP641.201072	ROT. HP641.201065	ROT. HP641.201997	ROT. HP643.200984	ROT. HP643.201681	ROT. HP643.201133	ROT. HP643.200983	RAV. G7441.201140	RAV. G7441.200969	RAV. G7441.201119	RAV. G7441.200716	RAV. G7441.200877	RAV. G7441.200921	RAV. G7641.200945	RAV. G7641.200006	RAV. G7641.201041	RAV. G7641.200907	RAV. G7641.200889	RAV. G7641.201010	RAV. G7641.201089	RAV. G7641.200761	RAV. G7645.201232	RAV. G7645.200914	RAV. G7645.200990	RAV. G8645.201249	SPA. GA441.200976	SPA. GA441.201126	SPA. GA441.202000	SPA. GA641.201027	SPA. GA641.201096	SPA. GA641.200952	SPA. GA641.201058	SPA. GA645.200600	
	●	●	●	●																●	●	●	●														●	●		
#		D.R	N	Descrizione	Description	Beschreibung	Description	Descripción																																

1	✓		201094	TE M6x40	TE M6x40 bolt	Schraube TE M6x40	Vis TE M6x40	Tornillo TE M6x40				
2	✓		203035	TE M8x20	TE M8x20 bolt	Schraube TE M8x20	Vis TE M8x20	Tornillo TE M8x20				
3	✓		213126	STEI coppa M6x8	STEI M6x8 cup bolt	Topfschraube STEI M6x8	Vis STEI M6x8 flasque	Tornillo STEI M6x8 copa				
4	✓		210126	STEI M6x8	STEI M6x8 bolt	Schraube STEI M6x8	Vis STEI M6x8	Tornillo STEI M6x8				
5	✓		224011	Dado esagonale medio M10	M10 med. hex nut	Mittlere Sechskantmutter M10	Écrou hexagonal moyen M10	Tuerca hexagonal medio M10				
6	✓		228010	Dado autobloccante M6	M6 self-locking nut	Selbstsichernde Mutter M6	Écrou auto-bloquant M6	Tuerca autobloccante M6				
7	✓		231003	Chiavetta 6x6x25	6x6x25 wrench	Schlüssel 6x6x25	Clé 6x6x25	Llave 6x6x25				
8	✓		231068	Chiavetta 10x8x45	10x8x45 wrench	Schlüssel 10x8x45	Clé 10x8x45	Llave 10x8x45				
9	✓		237037	Rondella piana tranciante 8x32x2,5	8x32x2,5 flat washer	Ebene Schneidscheibe 8x32x2,5	Rondelle plane 8x32x2,5	Arandela plana 8x32x2,5				
10	✓		237046	Rondella piana 6x24x2	6x24x2 flat washer	Ebene Unterlagsscheibe 6x24x2	Rondelle plane 6x24x2	Arandela plana 6x24x2				
11	✓		239041	Rondella dentata 10,5	10.5 toothed washer	Zahnunterlagscheibe 10,5	Rondelle dentée 10,5	Arandela dentada 10,5				
12	✓		239023	Rondella dentata 8,4	8.4 toothed washer	Zahnunterlagscheibe 8,4	Rondelle dentée 8,4	Arandela dentada 8,4				
13	✓		412103	Cinghia	Belt	Riemen	Courroie	Correa				
14	✓		412081	Rondella gomma	Rubber washer	Gummischeibe	Rondelle en caoutchouc	Arandela en goma				
15	✓		14030528	Tirante per riduttore M10x210	M10x210 tie rod for reduction gear	Spannstange für Untersetzer M10x210	Tirant pour réducteur M10x210	Jalador para reductor M10x210				
16	✓		14030532	Tirante per riduttore M10x170	M10x170 tie rod for reduction gear	Spannstange für Untersetzer M10x170	Tirant pour réducteur M10x170	Jalador para reductor M10x170				
17	✓		730012420	Puleggia D.132	D.132 pulley	Riemenscheibe D.132	Poulie D.132	Polea D.132				
18	✓		140305263	Piastra motore zincata	Galvanized motor plate	Verzinkte Motorplatte	Plaque moteur galvanisée	Placa de motor galvanizada				
19	✓		140305521	Insieme riduttore	Reduction gear assembly	Untersetzersatz	Ensemble réducteur	Conjunto reductor				
20	✓		730091013	Gruppo motore	Motor assembly	Motorsatz	Ensemble moteur	Conjunto motor				
21	✓		730014030	Puleggia	Pulley	Riemenscheibe	Poulie	Polea				
22	✓		213378	STEI M5x6	STEI M5x6 bolt	Schraube STEI M5x6	Vis STEI M5x6	Tornillo STEI M5x6				
23	✓		210148	STEI M5x6	STEI M5x6 bolt	Schraube STEI M5x6	Vis STEI M5x6	Tornillo STEI M5x6				
24	✓		900071190	Guarnizione	Gasket	Dichtung	Joint	Junta				
25	✓		900071180	Coperchio morsettiera	Termination box cover	Klemmenbrettsdeckung	Cowercle bornier	Tapa bornero				
26	✓		900003720	Motore 0,75 kW	0.75 kW motor	Motor 0,75 kW	Moteur 0,75 kW	Motor 0,75 kW				
27	✓		236007	Rondella piana 10,5x21x2	Fe 10.5x21x2 washer	Ebene Unterlagsscheibe 10,5x21x2	Rondelle Fe 10,5x21x2	Arandela Fe 10,5x21x2				
28	✓		226011	Dado esagonale basso M10	M10 jam hex nut	Niedrige Sechskantmutter M10	Écrou hexagonal bas M10	Tuerca hexagonal baja M10				
29	✓		730015400	Tappo protezione	Protection plug	Schutzstöpsel	Bouchon protection	Tapón protección				
30	✓		790065110	Cavo di terra	Ground cable	Erdkabel	Câble de masse	Cable tierra				



**LISTA DEI COMPONENTI - LIST OF COMPONENTS - TEILELISTE  
LISTE DES PIECES DETACHEES - LISTA DE PIEZAS**

KIT MOTORIDUTTORE  
GEARMOTOR KIT  
UNTERSETZERSET  
KIT MOTOREDUCTEUR  
KIT MOTORREDUCTOR

**Pag. 84 di 235**

**Tavola N°8B - Rev. 0**

**730098140**

ROT. HP441.201102	ROT. HP641.200938	ROT. HP641.201034	ROT. HP641.200891	ROT. HP641.200785	ROT.HP641.201003	ROT.HP641.201788	ROT. HP641.201072	ROT. HP641.201065	ROT. HP641.201997	ROT.HP643.200984	ROT.HP643.201681	ROT. HP643.201133	ROT. HP643.200983	RAV. G7441.201140	RAV. G7441.200969	RAV. G7441.201119	RAV. G7441.200716	RAV. G7441.200877	RAV. G7441.200921	RAV. G7641.200945	RAV. G7641.200006	RAV. G7641.201041	RAV.G7641.200907	RAV.G7641.200689	RAV. G7641.201010	RAV. G7641.201089	RAV. G7641.200761	RAV. G7645.201232	RAV. G7645.200914	RAV. G7645.200990	RAV. G8645.201249	SPA. GA441.200976	SPA. GA441.201126	SPA. GA441.202000	SPA. GA641.201027	SPA. GA641.201096	SPA. GA641.200952	SPA. GA641.201058	SPA. GA645.200600						
	•	•	•	•																•	•	•	•														•	•							
<b>#</b>		<b>D.R</b>	<b>N</b>	<b>Descrizione</b>	<b>Description</b>	<b>Beschreibung</b>	<b>Description</b>	<b>Descripción</b>																																					

<b>31</b>	✓		203208	TE M5x20	TE M5x20 bolt	Schraube TE M5x20	Vis TE M5x20	Tornillo TE M5x20																																								
<b>32</b>	✓		239017	Rosetta	Washer	Unterlegscheibe	Rondelle	Arandela																																								
<b>33</b>	✓		224005	Dado medio M5	M5 med nut	Mittlere Mutter M5	Écrou moyen M5	Tuerca media M5																																								

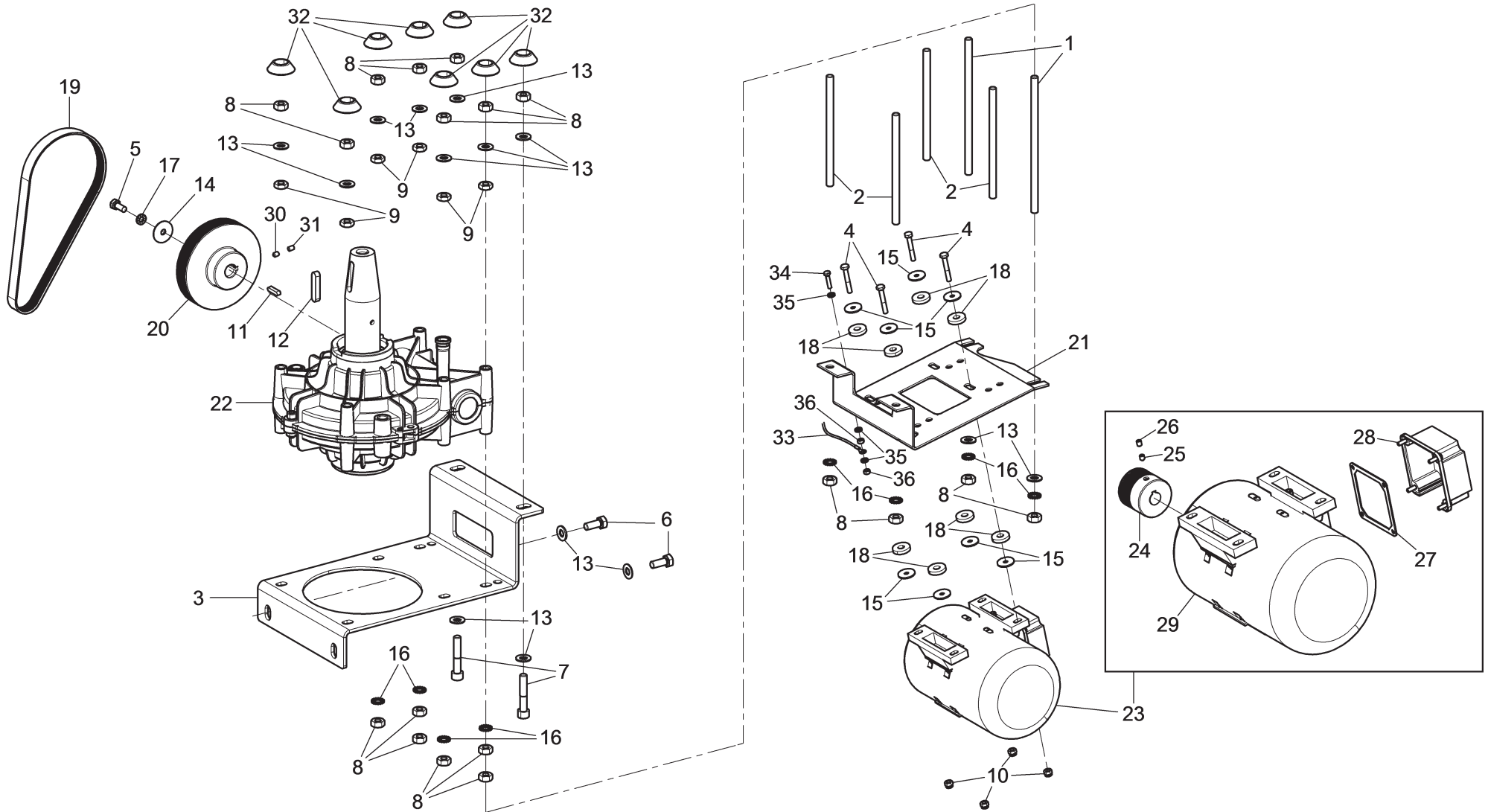

ROT. HP441.201102	ROT. HP641.200838	ROT. HP641.201034	ROT. HP641.200891	ROT. HP641.200785	ROT.HP641.201003 ROT.HP641.201788	ROT. HP641.201072	ROT. HP641.201065	ROT. HP641.201897	ROT.HP643.200894 ROT.HP643.201881	ROT. HP643.201133	ROT. HP643.200983	RAV. G7441.201140	RAV. G7441.200969	RAV. G7441.201119	RAV. G7441.200716	RAV. G7441.200877	RAV. G7441.200821	RAV. G7641.200945	RAV. G7641.200006	RAV. G7641.201041	RAV.G7641.200907 RAV.G7641.200683	RAV. G7641.201010	RAV. G7641.201089	RAV. G7641.200761	RAV. G7645.201232	RAV. G7645.200914	RAV. G7645.200990	RAV. G8645.201249	SFA. GA441.200976	SFA. GA441.201126	SFA. GA441.202000	SFA. GA641.201027	SFA. GA641.201096	SFA. GA641.200952	SFA. GA641.201058	SFA. GA645.200600				
									•	•	•														•	•	•	•												•
		<b>LISTA DEI COMPONENTI - LIST OF COMPONENTS - TEILELISTE</b> <b>LISTE DES PIÈCES DÉTACHÉES - LISTA DE PIEZAS</b>																			<b>KIT MOTORIDUTTORE INVERTER</b> <b>INVERTER GEARMOTOR KIT</b> <b>FREQUENZUMFORMER-UNTERSETZERSSET</b> <b>KIT MOTOREDUCTEUR INVERSEUR</b> <b>KIT MOTORREDUCTOR INVERSOR</b>																			
		<b>Tavola N°8C - Rev. 0</b>											<b>730097570</b>						<b>Pag. 85 di 235</b>																					





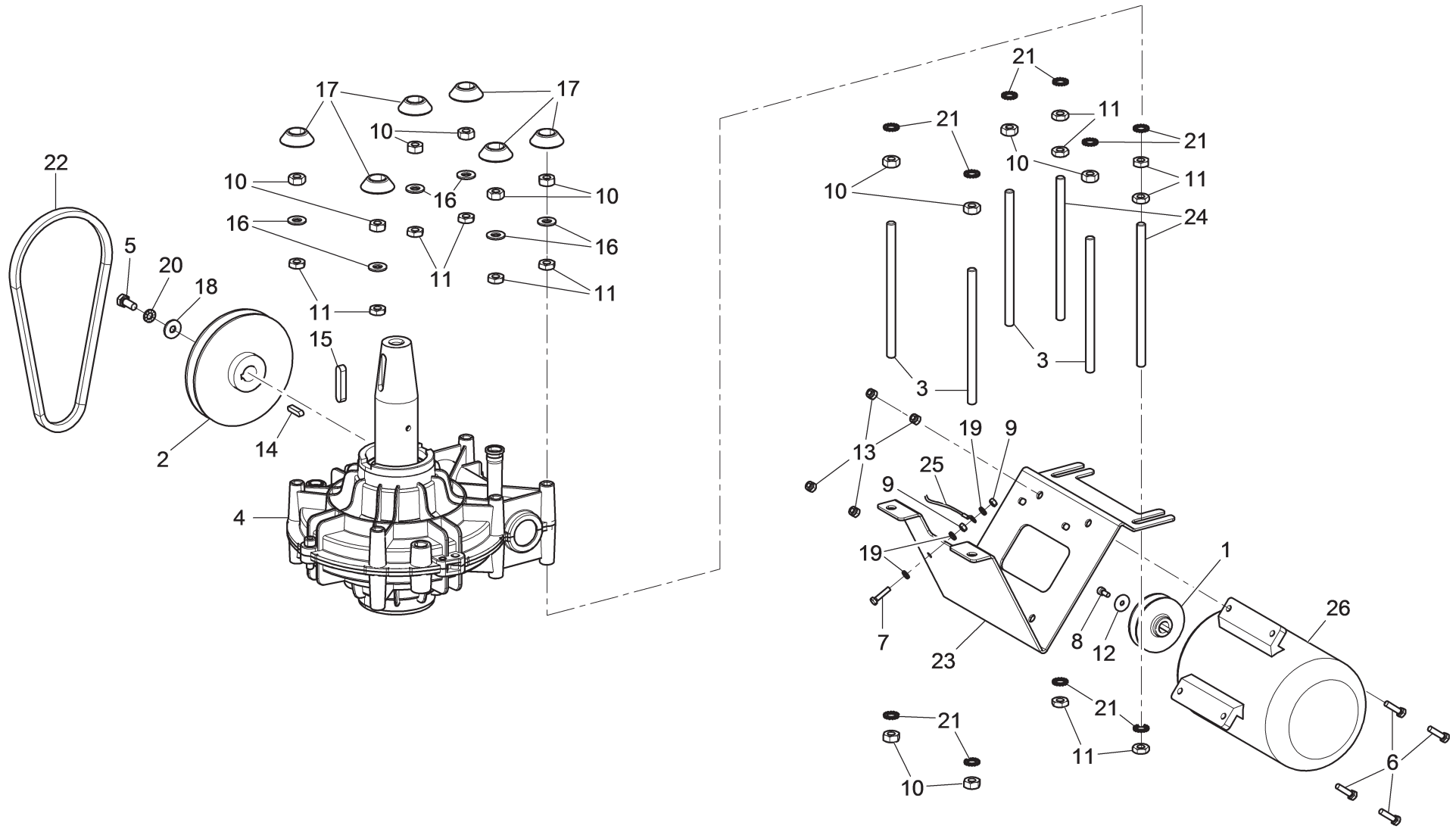

ROT. HF441.201102	ROT. HF641.200938	ROT. HF641.201034	ROT. HF641.200891	ROT. HF641.200785	ROT.HF641.201003 ROT.HF641.201788	ROT. HF641.201072	ROT. HF641.201065	ROT. HF641.201997	ROT.HF643.200984 ROT.HF643.201681	ROT. HF643.201133	ROT. HF643.200983	RAV G7441.201140	RAV G7441.200969	RAV G7441.201119	RAV G7441.200716	RAV G7441.200877	RAV G7441.200921	RAV G7641.200945	RAV G7641.200006	RAV G7641.201041	RAV.G7641.200907 RAV.G7641.200689	RAV G7641.201010	RAV G7641.201089	RAV G7641.200761	RAV G7645.201232	RAV G7645.200914	RAV G7645.200990	RAV G8645.201249	SFA GA441.200976	SFA GA441.201126	SFA GA441.202000	SFA GA641.201027	SFA GA641.201096	SFA GA641.200952	SFA GA641.201058	SFA GA645.200600		
									●	●	●														●	●	●	●										●
#		D.R	N	Descrizione	Description	Beschreibung	Description	Descripción																														

1	✓		14030528	Tirante per riduttore M10x210	M10x210 tie rod for reduction gear	Spannstange für Untersetzer M10x210	Tirant pour réducteur M10x210	Jalador para reductor M10x210																														
2	✓		14030532	Tirante per riduttore M10x170	M10x170 tie rod for reduction gear	Spannstange für Untersetzer M10x170	Tirant pour réducteur M10x170	Jalador para reductor M10x170																														
3	✓		140833340	Supporto riduttore	Reduction gear support	Untersetzerträger	Support réducteur	Soporte reductor																														
4	✓		201094	TE M6x40	TE M6x40 bolt	Schraube TE M6x40	Vis TE M6x40	Tornillo TE M6x40																														
5	✓		203035	TE M8x20	TE M8x20 bolt	Schraube TE M8x20	Vis TE M8x20	Tornillo TE M8x20																														
6	✓		203058	TE M10x25	TE M10x25 bolt	Schraube TE M10x25	Vis TE M10x25	Tornillo TE M10x25																														
7	✓		206108	TCEI M10x55	TCEI M10x55 bolt	Schraube TCEI M10x55	Vis TCEI M10x55	Tornillo TCEI M10x55																														
8	✓		224011	Dado esagonale medio M10	M10 med. hex nut	Mittlere Sechskantmutter M10	Écrou hexagonal moyen M10	Tuerca hexagonal medio M10																														
9	✓		226011	Dado esagonale basso M10	M10 jam hex nut	Niedrige Sechskantmutter M10	Écrou hexagonal bas M10	Tuerca hexagonal baja M10																														
10	✓		228010	Dado autobloccante M6	M6 self-locking nut	Selbstsichernde Mutter M6	Écrou auto-bloquant M6	Tuerca autobloccante M6																														
11	✓		231003	Chiavetta 6x6x25	6x6x25 wrench	Schlüssel 6x6x25	Clé 6x6x25	Llave 6x6x25																														
12	✓		231068	Chiavetta 10x8x45	10x8x45 wrench	Schlüssel 10x8x45	Clé 10x8x45	Llave 10x8x45																														
13	✓		236007	Rondella piana 10,5x21x2	Fe 10.5x21x2 washer	Ebene Unterlagsscheibe 10,5x21x2	Rondelle Fe 10,5x21x2	Arandela Fe 10,5x21x2																														
14	✓		237037	Rondella piana tranciante 8x32x2,5	8x32x2.5 flat washer	Ebene Schneidscheibe 8x32x2,5	Rondelle plane 8x32x2,5	Arandela plana 8x32x2,5																														
15	✓		237046	Rondella piana 6x24x2	6x24x2 flat washer	Ebene Unterlagsscheibe 6x24x2	Rondelle plane 6x24x2	Arandela plana 6x24x2																														
16	✓		239041	Rondella dentata 10,5	10.5 toothed washer	Zahnunterlagscheibe 10,5	Rondelle dentée 10,5	Arandela dentada 10,5																														
17	✓		239023	Rondella dentata 8,4	8.4 toothed washer	Zahnunterlagscheibe 8,4	Rondelle dentée 8,4	Arandela dentada 8,4																														
18	✓		412081	Rondella gomma	Rubber washer	Gummischeibe	Rondelle en caoutchouc	Arandela en goma																														
19	✓		412103	Cinghia	Belt	Riemen	Courroie	Correa																														
20	✓		730012420	Puleggia D.132	D.132 pulley	Riemenscheibe D.132	Poulie D.132	Polea D.132																														
21	✓		140305263	Piastra motore zincata	Galvanized motor plate	Verzinkte Motorplatte	Plaque moteur galvanisée	Placa de motor galvanizada																														
22	✓		140305521	Insieme riduttore	Reduction gear assembly	Untersetzersatz	Ensemble réducteur	Conjunto reductor																														
23	✓		730091013	Gruppo motore	Motor assembly	Motorsatz	Ensemble moteur	Conjunto motor																														
24	✓		730014030	Puleggia	Pulley	Riemenscheibe	Poulie	Polea																														
25	✓		213378	STEI M5x6	STEI M5x6 bolt	Schraube STEI M5x6	Vis STEI M5x6	Tornillo STEI M5x6																														
26	✓		210148	STEI M5x6	STEI M5x6 bolt	Schraube STEI M5x6	Vis STEI M5x6	Tornillo STEI M5x6																														
27	✓		900071190	Guarnizione	Gasket	Dichtung	Joint	Junta																														
28	✓		900071180	Coperchio morsettiera	Termination box cover	Klemmenbrettsdeckung	Couvercle bornier	Tapa bornero																														
29	✓		900003720	Motore 0,75 kW	0.75 kW motor	Motor 0,75 kW	Moteur 0,75 kW	Motor 0,75 kW																														
30	✓		213126	STEI coppa M6x8	STEI M6x8 cup bolt	Topfschraube STEI M6x8	Vis STEI M6x8 flasque	Tornillo STEI M6x8 copa																														





ROT. HP441.201102	ROT. HP641.200838	ROT. HF641.201034	ROT. HP641.200891	ROT. HF641.200785	ROT.HP641.201063	ROT.HP641.201788	ROT. HP641.201072	ROT. HF641.201065	ROT. HP641.201897	ROT.HP643.200884	ROT.HP643.201881	ROT. HP643.201133	ROT. HF643.200983	RAV. G7441.201140	RAV. G7441.200969	RAV. G7441.201119	RAV. G7441.200716	RAV. G7441.200877	RAV. G7441.200821	RAV. G7641.200945	RAV. G7641.200006	RAV. G7641.201041	RAV.G7641.200907	RAV.G7641.200683	RAV. G7641.201010	RAV. G7641.201089	RAV. G7641.200761	RAV. G7645.201232	RAV. G7645.200914	RAV. G7645.200990	RAV. G8645.201249	SPA. GA441.200976	SPA. GA441.201126	SPA. GA441.202000	SPA. GA641.201027	SPA. GA641.201096	SPA. GA641.200952	SPA. GA641.201058	SPA. GA645.200600							
														•	•																															
		<b>LISTA DEI COMPONENTI - LIST OF COMPONENTS - TEILELISTE</b> <b>LISTE DES PIECES DETACHEES - LISTA DE PIEZAS</b>																			KIT MOTORIDUTTORE GEARMOTOR KIT UNTERSATZSETZ KIT MOTOREDUCTEUR KIT MOTORREDUCTOR																									
		<b>Tavola N°8D - Rev. 1</b>					<b>730098590</b>																					<b>Pag. 88 di 235</b>																		

		<b>LISTA DEI COMPONENTI - LIST OF COMPONENTS - TEILELISTE</b> <b>LISTE DES PIÈCES DÉTACHÉES - LISTA DE PIEZAS</b>										KIT MOTORIDUTTORE GEARMOTOR KIT UNTERSETZERSET KIT MOTOREDUCTEUR KIT MOTORREDUCTOR										<b>Pag. 89 di 235</b>																					
		<b>Tavola N°8D - Rev. 1</b>					<b>730098590</b>																																				
ROT. HP641.201102	ROT. HP641.200938	ROT. HP641.201034	ROT. HP641.200891	ROT. HP641.200785	ROT. HP641.201003	ROT. HP641.201788	ROT. HP641.201072	ROT. HP641.201065	ROT. HP641.201997	ROT. HP643.200984	ROT. HP643.201681	ROT. HP643.201133	ROT. HP643.200983	RAV. G7441.201140	RAV. G7441.200969	RAV. G7441.201119	RAV. G7441.200716	RAV. G7441.200877	RAV. G7441.200821	RAV. G7641.200945	RAV. G7641.200006	RAV. G7641.201041	RAV. G7641.200907	RAV. G7641.200689	RAV. G7641.201010	RAV. G7641.201089	RAV. G7641.200761	RAV. G7645.201232	RAV. G7645.200914	RAV. G7645.200990	RAV. G8645.201249	SFA. GA441.200976	SFA. GA441.201126	SFA. GA441.202000	SFA. GA641.201027	SFA. GA641.201096	SFA. GA641.200952	SFA. GA641.201058	SFA. GA645.200600				
														●	●																												
#		D.R	N	Descrizione	Description	Beschreibung	Description	Descripción																																			

1	✓		B5068001	Puleggia	Pulley	Riemenscheibe	Poulie	Polea				
2	✓		B8463000	Puleggia D.132	D.132 pulley	Riemenscheibe D.132	Poulie D.132	Polea D.132				
3	✓		14030532	Tirante per riduttore M10x170	M10x170 tie rod for reduction gear	Spannstange für Untersetzer M10x170	Tirant pour réducteur M10x170	Jalador para reductor M10x170				
4	✓		140305521	Insieme riduttore	Reduction gear assembly	Untersetzerssatz	Ensemble réducteur	Conjunto reductor				
5	✓		203035	TE M8x20	TE M8x20 bolt	Schraube TE M8x20	Vis TE M8x20	Tornillo TE M8x20				
6	✓		203127	TE M6x25	TE M6x25 bolt	Schraube TE M6x25	Vis TE M6x25	Tornillo TE M6x25				
7	✓		203208	TE M5x20	TE M5x20 bolt	Schraube TE M5x20	Vis TE M5x20	Tornillo TE M5x20				
8	✓		206207	TCEI M5x12	TCEI M5x12 bolt	Schraube TCEI M5x12	Vis TCEI M5x12	Tornillo TCEI M5x12				
9	✓		224005	Dado medio M5	M5 med nut	Mittlere Mutter M5	Écrou moyen M5	Tuerca media M5				
10	✓		224011	Dado esagonale medio M10	M10 med. hex nut	Mittlere Sechskantmutter M10	Écrou hexagonal moyen M10	Tuerca hexagonal medio M10				
11	✓		226011	Dado esagonale basso M10	M10 jam hex nut	Niedrige Sechskantmutter M10	Écrou hexagonal bas M10	Tuerca hexagonal baja M10				
12	✓		237010	Rondella piana 5,5x20x1,5	5x20x1.5 washer	Ebene Unterlagsscheibe 5x20x1,5	Rondelle 5x20x1,5	Arandela 5x20x1,5				
13	✓		228010	Dado autobloccante M6	M6 self-locking nut	Selbstsichernde Mutter M6	Écrou auto-bloquant M6	Tuerca autobloccante M6				
14	✓		231003	Chiavetta 6x6x25	6x6x25 wrench	Schlüssel 6x6x25	Clé 6x6x25	Llave 6x6x25				
15	✓		231068	Chiavetta 10x8x45	10x8x45 wrench	Schlüssel 10x8x45	Clé 10x8x45	Llave 10x8x45				
16	✓		236007	Rondella piana 10,5x21x2	Fe 10.5x21x2 washer	Ebene Unterlagsscheibe 10,5x21x2	Rondelle Fe 10,5x21x2	Arandela Fe 10,5x21x2				
17	✓		730015400	Tappo protezione	Protection plug	Schutzstöpsel	Bouchon protection	Tapón protección				
18	✓		237037	Rondella piana tranciante 8x32x2,5	8x32x2.5 flat washer	Ebene Schneidscheibe 8x32x2,5	Rondelle plane 8x32x2,5	Arandela plana 8x32x2,5				
19	✓		239017	Rosetta	Washer	Untertegscheibe	Rondelle	Arandela				
20	✓		239023	Rondella dentata 8,4	8.4 toothed washer	Zahnunterlagscheibe 8,4	Rondelle dentée 8,4	Arandela dentada 8,4				
21	✓		239041	Rondella dentata 10,5	10.5 toothed washer	Zahnunterlagscheibe 10,5	Rondelle dentée 10,5	Arandela dentada 10,5				
22	✓		412091	Cinghia trapezoidale	Trapezoidal belt	Trapezriemen	Courroie trapézoidal	Correa trapezoidal				
23	✓		730023581	Lama supporto motore	Motor support blade	Motorstützklinge	Lame support moteur	Cuchilla soporte motor				
24	✓		730023650	Barra filettata M10x180	Threaded bar M10x180	Gewindestange M10x180	Barre fileté M10x180	Barra roscada M10x180				
25	✓		790065110	Cavo di terra	Ground cable	Erdkabel	Câble de masse	Cable tierra				
26	✓		900003590	Motore kW 0.75.230-400 50 Hz	kW 0.75.230-400 50 Hz motor	Motor kW 0.75.230-400 50 Hz	Moteur kW 0.75.230-400 50 Hz	Motor kW 0.75.230-400 50 Hz				

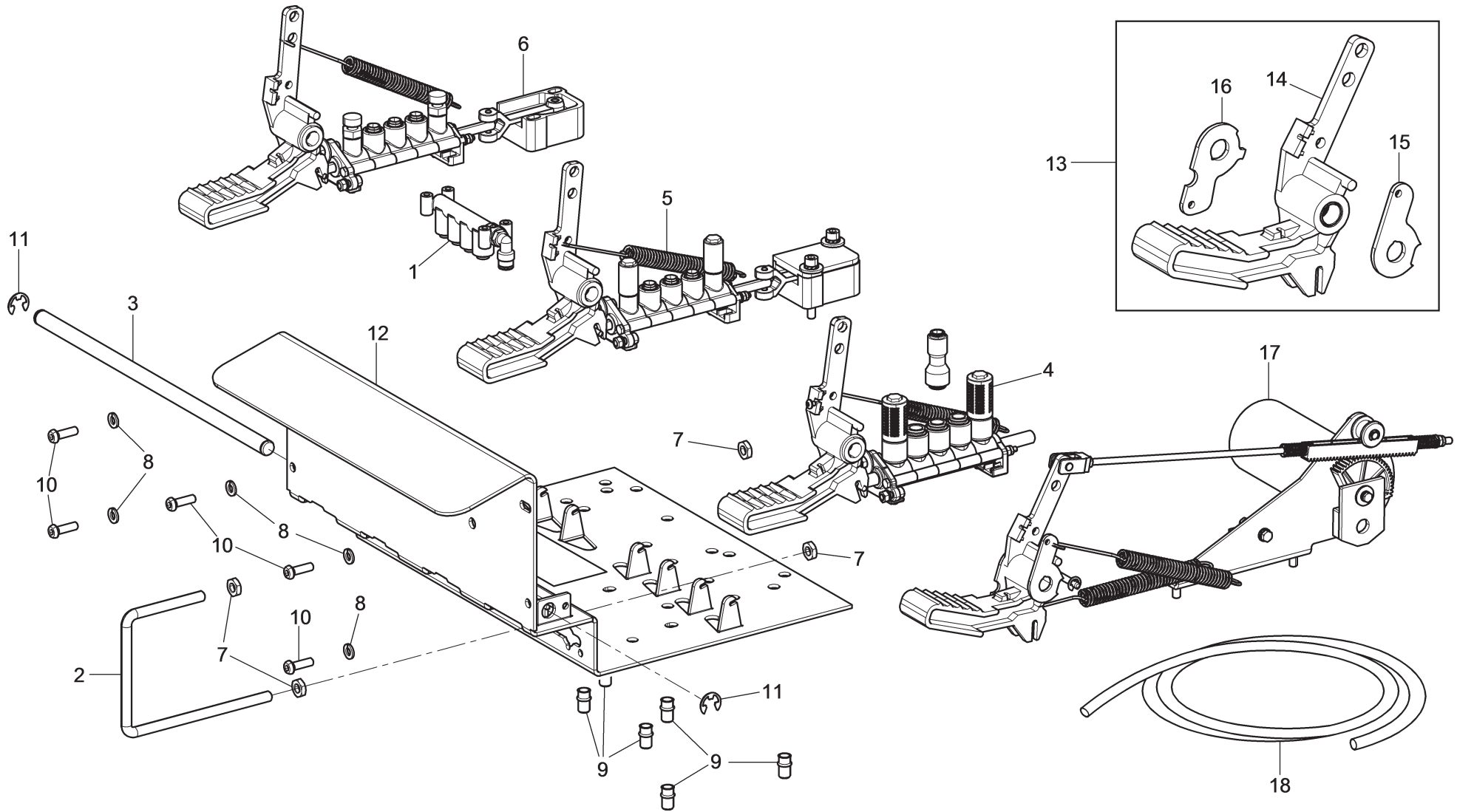

ROT. HP441.201102	ROT. HP641.200888	ROT. HP641.201034	ROT. HP641.200891	ROT. HP641.200785	ROT:HP641.201003 ROT:HP641.201788	ROT. HP641.201072	ROT. HP641.201065	ROT. HP641.201897	ROT:HP643.200894 ROT:HP643.201881	ROT. HP643.201133	ROT. HP643.200983	RAV. G7441.201140	RAV. G7441.200969	RAV. G7441.201119	RAV. G7441.200716	RAV. G7441.200877	RAV. G7441.200821	RAV. G7641.200945	RAV. G7641.200006	RAV. G7641.201041	RAV:G7641.200907 RAV:G7641.200683	RAV. G7641.201010	RAV. G7641.201089	RAV. G7641.200761	RAV. G7645.201232	RAV. G7645.200914	RAV. G7645.200990	RAV. G8645.201249	SPA. GA441.200976	SPA. GA441.201126	SPA. GA441.202000	SPA. GA641.201027	SPA. GA641.201096	SPA. GA641.200952	SPA. GA641.201058	SPA. GA645.200600					
●				●	●	●	●						●	●	●	●				●	●	●									●	●	●								
		<b>LISTA DEI COMPONENTI - LIST OF COMPONENTS - TEILELISTE</b> <b>LISTE DES PIÈCES DÉTACHÉES - LISTA DE PIEZAS</b>																		KIT PEDALIERA PEDALBOARD KIT PEDALSTEUERUNGSET KIT PEDALIER KIT PEDALERA						▶															
		<b>Tavola N°9A - Rev. 0</b>									<b>730098300</b>									<b>Pag. 90 di 235</b>																					



LISTA DEI COMPONENTI - LIST OF COMPONENTS - TEILELISTE  
LISTE DES PIÈCES DÉTACHÉES - LISTA DE PIEZAS

KIT PEDALIERA  
PEDALBOARD KIT  
PEDALSTEUERUNGSET  
KIT PÉDALIER  
KIT PEDALERA

Tavola N°9A - Rev. 0

730098300

ROT. HP441.201102	ROT. HP641.200938	ROT. HP641.201034	ROT. HP641.200891	ROT. HP641.200785	ROT. HP641.201003	ROT. HP641.201788	ROT. HP641.201072	ROT. HP641.201065	ROT. HP641.201997	ROT. HP643.200984	ROT. HP643.201681	ROT. HP43.201133	ROT. HP643.200983	RAV. G7441.201140	RAV. G7441.200969	RAV. G7441.201119	RAV. G7441.200716	RAV. G7441.200877	RAV. G7441.200921	RAV. G7641.200945	RAV. G7641.200006	RAV. G7641.201041	RAV. G7641.200907	RAV. G7641.200689	RAV. G7641.201010	RAV. G7641.201089	RAV. G7641.200761	RAV. G7645.201232	RAV. G7645.200914	RAV. G7645.200990	RAV. G8645.201249	SFA. GA441.200976	SFA. GA441.201126	SFA. GA441.202000	SFA. GA641.201027	SFA. GA641.201096	SFA. GA641.200952	SFA. GA641.201058	SFA. GA645.200600		
●				●	●	●	●	●	●						●	●	●	●	●					●	●	●							●	●	●	●					
#		D.R	N	Descrizione	Description	Beschreibung	Description	Descripción																																	

1	✓		B2850001	Blocchetto a 5 vie	5-way block	5-Wege-Blöckchen	Petit block à 5 voies	Bloque a 5 vías			
2	✓		140910280	Divisore pedali	Pedal partition	Trennpedalen	Diviseur pédales	Divisor pedales			
3	✓		140915170	Perno fulcro pedali	Pedals pivot pin	Drehpunktzapfen der Pedalen	Pivot point d'appui pédales	Perno fulcro pedales			
4	✓	10.0	140990391	Insieme pedale stallonatore	Bead breaker pedal assembly	Abdrückpedalsatz	Ensemble pédale décolle-pneus	Conjunto pedal destalonador			
5	✓	11.0	140990401	Insieme pedale mandrino	Chuck pedal assembly	Spindelpedalsatz	Ensemble pédale mandrin	Conjunto pedal mandril			
6	✓	12.0	140990431	Gruppo pedale	Pedal assembly	Pedalsatz	Ensemble pédal	Conjunto pedal			
7	✓		226009	Dado basso M8	M8 jam nut	Untere Mutter M8	Écrou bas M8	Tuerca baja M8			
8	✓		238004	Rondella elastica 6,4	6.4 spring washer	Elastische Unterlagsscheibe 6,4	Rondelle elastique 6,4	Arandela elástica 6,4			
9	✓		251102	Inserito filettato	Threaded insert	Gewindeinsatz	Renfort fileté	Inserito roscado			
10	✓		271021	TBEI M6x20	TBEI M6x20 bolt	Schraube TBEI M6x20	Vis TBEI M6x20	Tornillo TBEI M6x20			
11	✓		299052	Anello di fermo D.9	D.9 stopper ring	Stoppring D.9	Anneau d'arrêt D.9	Anillo de seguro D.9			
12	✓		730026151	Corpo pedaliera	Pedalboard body	Pedalengehäuse	Corps pédalier	Cuerpo pedalera			
13	✓		730070650	Kit sostituzione pedale	Pedal replacement kit	Set für Ersetzung des Pedals	Kit substitution pédale	Kit sustitución pedal			
14	✓		730097111	Pedale	Pedal	Pedal	Pédale	Pedal			
15	✓		730029190	Camma superiore	Upper cam	Obere Nocke	Came supérieure	Leva superior			
16	✓		730029200	Camma inferiore	Lower cam	Untere Nocke	Came inférieure	Leva inferior			
17	✓	13A.0	730098310	Pedale	Pedal	Pedal	Pédale	Pedal			
18	✓		317007	Tube rilsan 8x6 nero	8x6 black rilsan hose	Rilsan Rohr 8x6 schwarz	Tuyau rilsan 8x6 noir	Tubo rilsan 8x6 negro			

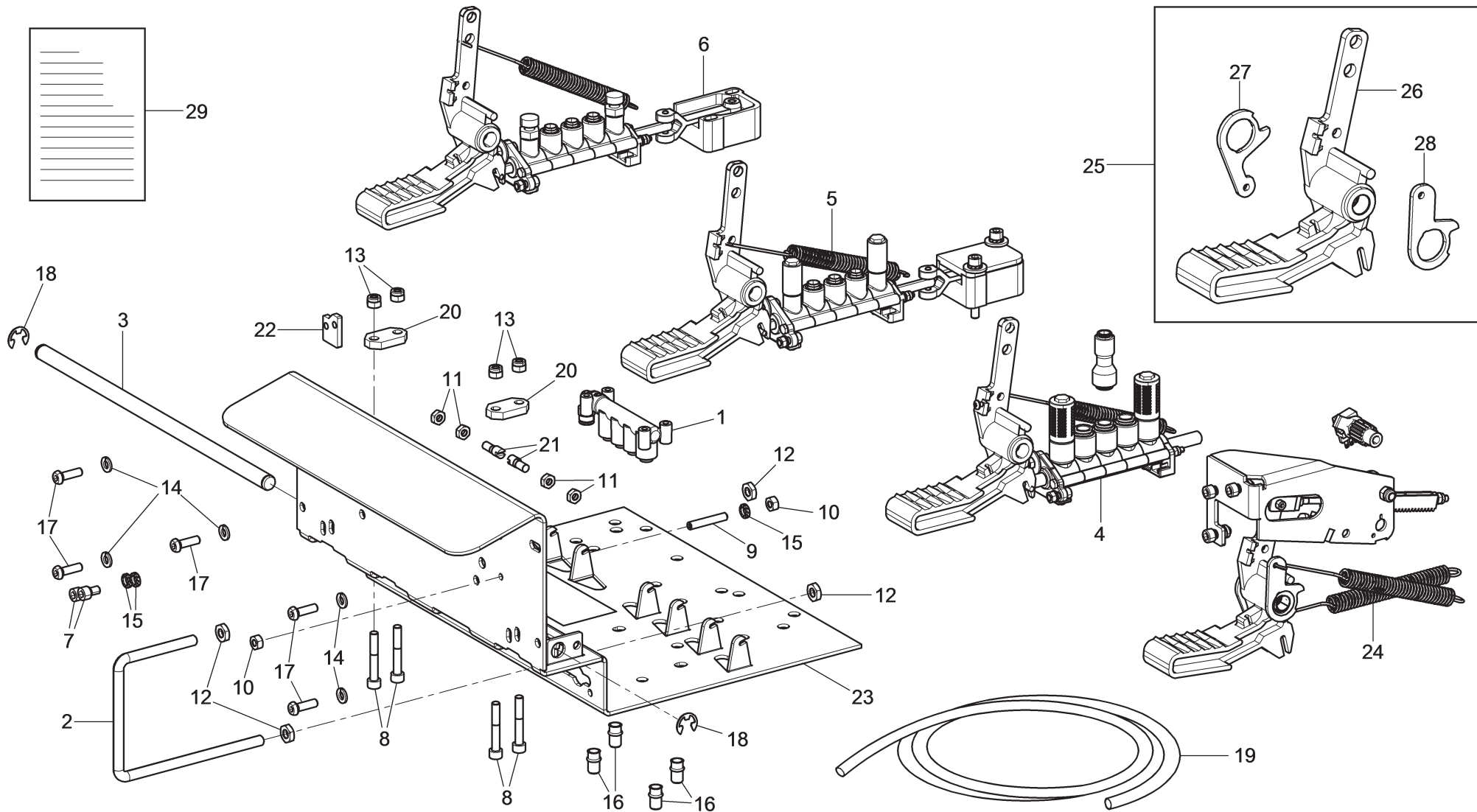

ROT. HP441.201102	ROT. HP641.200888	ROT. HP641.201034	ROT. HP641.200891	ROT. HP641.200785	ROT. HP641.201003	ROT. HP641.201788	ROT. HP641.201072	ROT. HP641.201065	ROT. HP641.201897	ROT. HP643.200894	ROT. HP643.201881	ROT. HP643.201133	ROT. HP643.200983	RAV. G7441.201140	RAV. G7441.200969	RAV. G7441.201119	RAV. G7441.200716	RAV. G7441.200877	RAV. G7441.200921	RAV. G7641.200945	RAV. G7641.200006	RAV. G7641.201041	RAV. G7641.200907	RAV. G7641.200683	RAV. G7641.201010	RAV. G7641.201089	RAV. G7641.200761	RAV. G7645.201232	RAV. G7645.200914	RAV. G7645.200990	RAV. G8645.201249	SPA. GA441.200976	SPA. GA441.201126	SPA. GA441.202000	SPA. GA641.201027	SPA. GA641.201096	SPA. GA641.200952	SPA. GA641.201058	SPA. GA645.200600				
	•	•	•	•																•	•	•	•																				



**LISTA DEI COMPONENTI - LIST OF COMPONENTS - TEILELISTE  
LISTE DES PIÈCES DÉTACHÉES - LISTA DE PIEZAS**

**Tavola N°9B - Rev. 0**

**730098160**

KIT PEDALIERA  
PEDALBOARD KIT  
PEDALSTEUERUNGSET  
KIT PÉDALIER  
KIT PEDALERA

**Pag. 92 di 235**



LISTA DEI COMPONENTI - LIST OF COMPONENTS - TEILELISTE  
LISTE DES PIÈCES DÉTACHÉES - LISTA DE PIEZAS

KIT PEDALIERA  
PEDALBOARD KIT  
PEDALSTEUERUNGSET  
KIT PÉDALIER  
KIT PEDALERA

Tavola N°9B - Rev. 0

730098160

ROT. HF441.201102	ROT. HF641.200938	ROT. HF641.201034	ROT. HF641.200891	ROT. HF641.200785	ROT.HF641.201003 ROT.HF641.201788	ROT. HF641.201072	ROT. HF641.201065	ROT. HF641.201997	ROT.HF643.200984 ROT.HF643.201681	ROT. HF643.201133	ROT. HF643.200983	RAV. G7441.201140	RAV. G7441.200969	RAV. G7441.201119	RAV. G7441.200716	RAV. G7441.200877	RAV. G7441.200921	RAV. G7641.200945	RAV. G7641.200006	RAV. G7641.201041	RAV.G7641.200907 RAV.G7641.200889	RAV. G7641.201010	RAV. G7641.201089	RAV. G7641.200761	RAV. G7645.201232	RAV. G7645.200914	RAV. G7645.200990	RAV. G8645.201249	SFA. GA441.200976	SFA. GA441.201126	SFA. GA441.202000	SFA. GAG41.201027	SFA. GAG41.201096	SFA. GAG41.200952	SFA. GAG41.201058	SFA. GAG45.200600		
●	●	●	●	●													●	●	●	●			●												●	●		

#		D.R	N	Descrizione	Description	Beschreibung	Description	Descripción		
---	--	-----	---	-------------	-------------	--------------	-------------	-------------	--	--

1	✓		B2850001	Blocchetto a 5 vie	5-way block	5-Wege-Blöckchen	Petit block à 5 votes	Bloque a 5 vías		
2	✓		140910280	Divisore pedali	Pedal partition	Trennpedalen	Diviseur pédales	Divisor pedales		
3	✓		140915170	Perno fulcro pedali	Pedals pivot pin	Drehpunktzapfen der Pedalen	Pivot point d'appui pédales	Perno fulcro pedales		
4	✓	10.0	140990391	Insieme pedale stallonatore	Bead breaker pedal assembly	Abdrückpedalsatz	Ensemble pédale décolle-pneus	Conjunto pedal destalonador		
5	✓	11.0	140990401	Insieme pedale mandrino	Chuck pedal assembly	Spindelpedalsatz	Ensemble pédale mandrin	Conjunto pedal mandril		
6	✓	12.0	140990431	Gruppo pedale	Pedal assembly	Pedalsatz	Ensemble pédal	Conjunto pedal		
7	✓		206012	TCEI M6x10	TCEI M6x10 bolt	Schraube TCEI M6x10	Vis TCEI M6x10	Tornillo TCEI M6x10		
8	✓		206094	TCEI M6x40	TCEI M6x40 bolt	Schraube TCEI M6x40	Vis TCEI M6x40	Tornillo TCEI M6x40		
9	✓		210093	STEI piana M6x35	M6x35 STEI flat bolt	Flachschrabe STEI M6x35	Vis STEI plane M6x35	Tornillo STEI plana M6x35		
10	✓		224007	Dado medio M6	M6 med nut	Mittlere Mutter M6	Écrou moyen M6	Tuerca media M6		
11	✓		226007	Dado basso M6	M6 jam nut	Untere Mutter M6	Écrou bas M6	Tuerca baja M6		
12	✓		226009	Dado basso M8	M8 jam nut	Untere Mutter M8	Écrou bas M8	Tuerca baja M8		
13	✓		228010	Dado autobloccante M6	M6 self-locking nut	Selbstsichernde Mutter M6	Écrou auto-bloquant M6	Tuerca autoblocante M6		
14	✓		238004	Rondella elastica 6,4	6.4 spring washer	Elastische Unterlagsscheibe 6,4	Rondelle elastique 6,4	Arandela elástica 6,4		
15	✓		239019	Rondella dentata 6,4	6.4 toothed washer	Zahnunterlagscheibe 6,4	Rondelle dentée 6,4	Arandela dentada 6,4		
16	✓		251102	Inserto filettato	Threaded insert	Gewindeinsatz	Renfort fileté	Inserto roscado		
17	✓		271021	TBEI M6x20	TBEI M6x20 bolt	Schraube TBEI M6x20	Vis TBEI M6x20	Tornillo TBEI M6x20		
18	✓		299052	Anello di fermo D.9	D.9 stopper ring	Stoppring D.9	Anneau d'arrêt D.9	Anillo de seguro D.9		
19	✓		317007	Tubo rilsan 8x6 nero	8x6 black rilsan hose	Rilsan Rohr 8x6 schwarz	Tuyau rilsan 8x6 noir	Tubo rilsan 8x6 negro		
20	✓		730014920	Piastrina	Plate	Plättchen	Plaquette	Placa		
21	✓		730014940	Riscontro	Stopper	Anschlag	Butée	Tope		
22	✓		730016430	Fermo	Stopper	Sperre	Arrêt	Seguro		
23	✓		730026492	Insieme pedale	Pedal assembly	Pedalsatz	Ensemble pédale	Conjunto pedal		
24	✓	13B.0	730096820	Gruppo pedale con inverter	Pedal assembly with inverter	Pedalsatz mit Frequenzumformer	Ensemble pédale avec inverteur	Conjunto pedal con inversor		
25	✓		730070290	Kit sostituzione pedale	Pedal replacement kit	Set für Ersetzung des Pedals	Kit substitution pédale	Kit sustitución pedal		
26	✓		730091391	Pedale con boccole	Pedal with bushings	Pedal mit Büchsen	Pédale avec douilles	Pedal con casquillos		
27	✓		730017990	Camma	Cam	Nocke	Came	Leva		
28	✓		730017980	Camma	Cam	Nocke	Came	Leva		
29	✓		7900M0280	Istruzioni sostituzione pedale inverter	Inverter pedal replacement instructions	Anweisungen zum Austausch der Frequenzumformer-Pedalen	Instructions de remplacement pédale inverseur	Instrucciones de reemplazo pedal inversor		

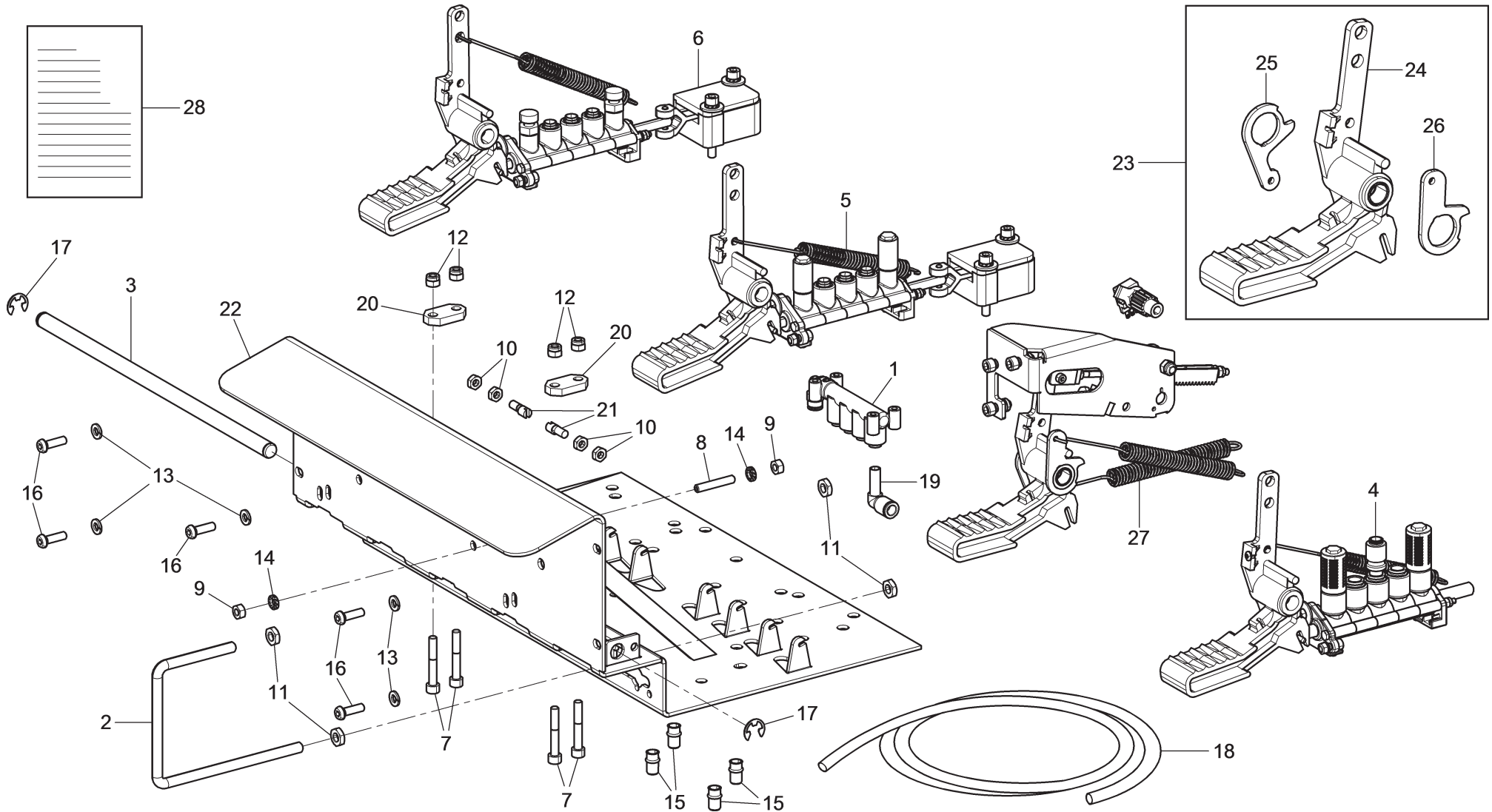

ROT. HP441.201102	ROT. HP641.200888	ROT. HP641.201034	ROT. HP641.200891	ROT. HP641.200785	ROT/HP641.201003	ROT/HP641.201788	ROT. HP641.201072	ROT. HP641.201065	ROT. HP641.201897	ROT/HP643.200894	ROT/HP643.201881	ROT. HP643.201133	ROT. HP643.200983	RAV. G7441.201140	RAV. G7441.200969	RAV. G7441.201119	RAV. G7441.200716	RAV. G7441.200877	RAV. G7441.200821	RAV. G7641.200945	RAV. G7641.200006	RAV. G7641.201010	RAV. G7641.201089	RAV. G7641.200761	RAV. G7645.201232	RAV. G7645.200914	RAV. G7645.200990	RAV. G8645.201249	SPA. GA441.200976	SPA. GA441.201126	SPA. GA441.202000	SPA. GA641.201027	SPA. GA641.201096	SPA. GA641.200952	SPA. GA641.201058	SPA. GA645.200600				
										•	•	•													•	•	•	•												•



LISTA DEI COMPONENTI - LIST OF COMPONENTS - TEILELISTE  
 LISTE DES PIÈCES DÉTACHÉES - LISTA DE PIEZAS







Tavola N°9C - Rev. 0

730097620

KIT PEDALIERA  
 PEDALBOARD KIT  
 PEDALSTEUERUNGSET  
 KIT PEDALIER  
 KIT PEDALERA



Pag. 94 di 235

				<b>LISTA DEI COMPONENTI - LIST OF COMPONENTS - TEILELISTE</b> <b>LISTE DES PIÈCES DÉTACHÉES - LISTA DE PIEZAS</b>										KIT PEDALIERA PEDALBOARD KIT PEDALSTEUERUNGSET KIT PÉDALIER KIT PEDALERA					<b>Pag. 95 di 235</b>	
<b>Tavola N°9C - Rev. 0</b>				<b>730097620</b>																
#		D.R	N	Descrizione	Description	Beschreibung	Description	Descripción												
1	✓		B2850001	Blocchetto a 5 vie	5-way block	5-Wege-Blöckchen	Petit block à 5 votes	Bloque a 5 vías												
2	✓		140910280	Divisore pedali	Pedal partition	Trennpedalen	Diviseur pédales	Divisor pedales												
3	✓		140915170	Perno fulcro pedali	Pedals pivot pin	Drehpunktzapfen der Pedalen	Pivot point d'appui pédales	Perno fulcro pedales												
4	✓	10.0	140990391	Insieme pedale stallonatore	Bead breaker pedal assembly	Abdrückpedalsatz	Ensemble pédale décolle-pneus	Conjunto pedal destalonador												
5	✓	11.0	140990401	Insieme pedale mandrino	Chuck pedal assembly	Spindelpedalsatz	Ensemble pédale mandrin	Conjunto pedal mandril												
6	✓	12.0	140990431	Gruppo pedale	Pedal assembly	Pedalsatz	Ensemble pédal	Conjunto pedal												
7	✓		206094	TCEI M6x40	TCEI M6x40 bolt	Schraube TCEI M6x40	Vis TCEI M6x40	Tornillo TCEI M6x40												
8	✓		210093	STEI piana M6x35	M6x35 STEI flat bolt	Flachschraube STEI M6x35	Vis STEI plane M6x35	Tornillo STEI plana M6x35												
9	✓		224007	Dado medio M6	M6 med nut	Mittlere Mutter M6	Écrou moyen M6	Tuerca media M6												
10	✓		226007	Dado basso M6	M6 jam nut	Untere Mutter M6	Écrou bas M6	Tuerca baja M6												
11	✓		226009	Dado basso M8	M8 jam nut	Untere Mutter M8	Écrou bas M8	Tuerca baja M8												
12	✓		228010	Dado autobloccante M6	M6 self-locking nut	Selbstsichernde Mutter M6	Écrou auto-bloquant M6	Tuerca autobloccante M6												
13	✓		238004	Rondella elastica 6,4	6.4 spring washer	Elastische Unterlagsscheibe 6,4	Rondelle elastique 6,4	Arandela elástica 6,4												
14	✓		239019	Rondella dentata 6,4	6.4 toothed washer	Zahnunterlagscheibe 6,4	Rondelle dentée 6,4	Arandela dentada 6,4												
15	✓		251102	Insero filettato	Threaded insert	Gewindeinsatz	Renfort fileté	Insero roscado												
16	✓		271021	TBEI M6x20	TBEI M6x20 bolt	Schraube TBEI M6x20	Vis TBEI M6x20	Tornillo TBEI M6x20												
17	✓		299052	Anello di fermo D.9	D.9 stopper ring	Stoppring D.9	Anneau d'arrêt D.9	Anillo de seguro D.9												
18	✓		317007	Tube rilsan 8x6 nero	8x6 black rilsan hose	Rilsan Rohr 8x6 schwarz	Tuyau rilsan 8x6 noir	Tube rilsan 8x6 negro												
19	✓		325186	Raccordo pneumatico L fisso 8-8	8-8 L pneumatic fixed fitting	Pneumatischer L-Festanschluss 8-8	Raccord pneumatique L fixe 8-8	Empalme neumático en L fijo 8-8												
20	✓		730014920	Piastrina	Plate	Plättchen	Plaque	Placa												
21	✓		730014940	Riscontro	Stopper	Anschlag	Butée	Tope												
22	✓		730026332	Insieme pedaliera	Pedalboard assembly	Pedalsteuerungssatz	Ensemble pédalier	Conjunto pedalera												
23	✓		730070290	Kit sostituzione pedale	Pedal replacement kit	Set für Ersetzung des Pedals	Kit substitution pédale	Kit sustitución pedal												
24	✓		730091391	Pedale con boccole	Pedal with bushings	Pedal mit Büchsen	Pédale avec douilles	Pedal con casquillos												
25	✓		730017990	Camma	Cam	Nocke	Came	Leva												
26	✓		730017980	Camma	Cam	Nocke	Came	Leva												
27	✓	13B.0	730096820	Gruppo pedale con inverter	Pedal assembly with inverter	Pedalsatz mit Frequenzumformer	Ensemble pédale avec inverseur	Conjunto pedal con inversor												
28	✓		7900M0280	Istruzioni sostituzione pedale inverter	Inverter pedal replacement instructions	Anweisungen zum Austausch der Frequenzumformer-Pedalen	Instructions de remplacement pédale inverseur	Instrucciones de reemplazo pedal inversor												

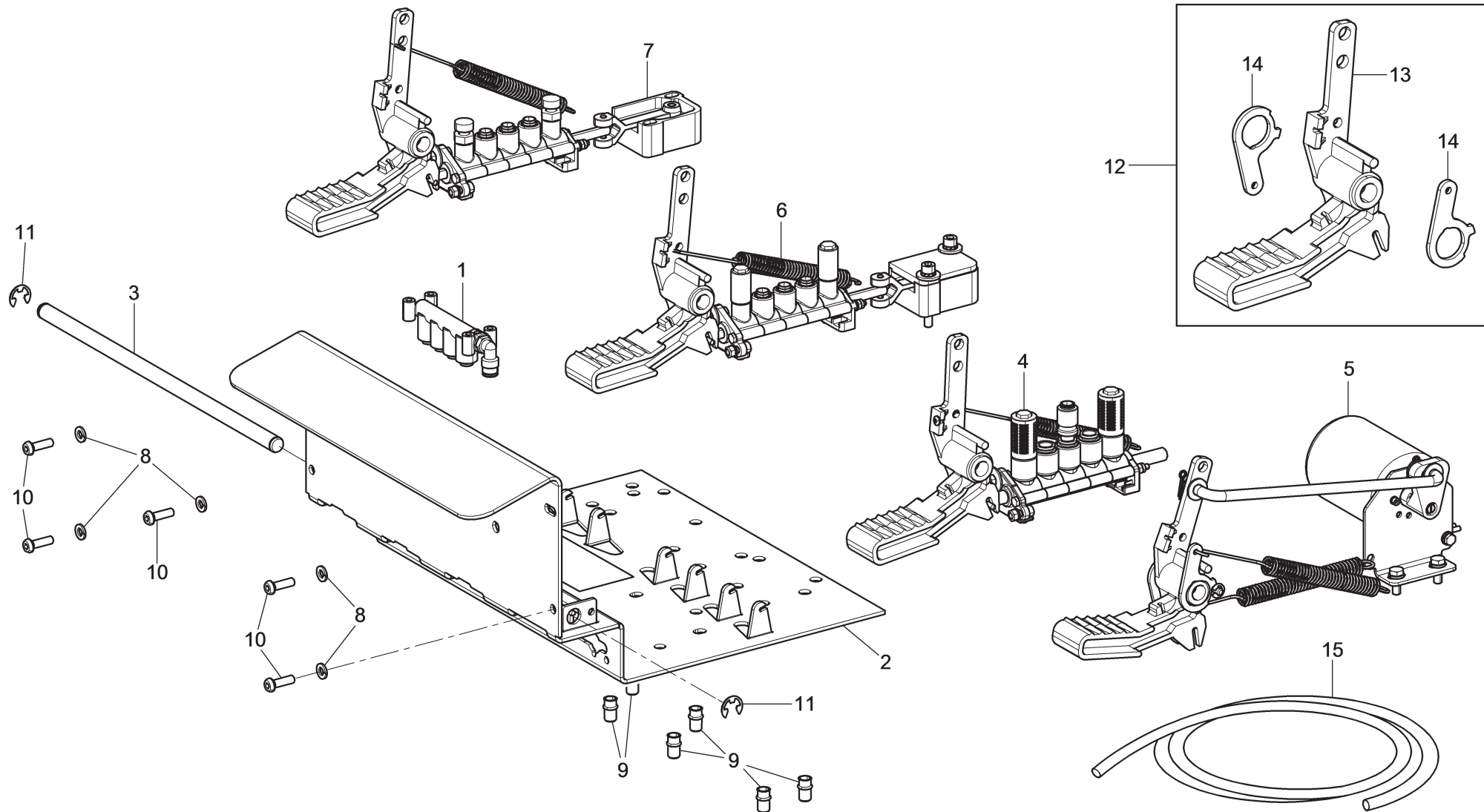

ROT. HP441.201102	ROT. HP641.200988	ROT. HP641.201034	ROT. HP641.200891	ROT. HP641.200785	ROT. HP641.201063	ROT. HP641.201788	ROT. HP641.201072	ROT. HP641.201065	ROT. HP641.201897	ROT. HP643.200894	ROT. HP643.201881	ROT. HP643.201133	ROT. HP643.200983	RAV. G7441.201140	RAV. G7441.200969	RAV. G7441.201119	RAV. G7441.200716	RAV. G7441.200877	RAV. G7441.200821	RAV. G7641.200945	RAV. G7641.200006	RAV. G7641.201041	RAV. G7641.200907	RAV. G7641.200983	RAV. G7641.201010	RAV. G7641.201089	RAV. G7641.200761	RAV. G7645.201232	RAV. G7645.200914	RAV. G7645.200990	RAV. G8645.201249	SPA. GA441.200976	SPA. GA441.201126	SPA. GA441.202000	SPA. GA641.201027	SPA. GA641.201096	SPA. GA641.200952	SPA. GA641.201058	SPA. GA645.200600																	
														●	●																																									



LISTA DEI COMPONENTI - LIST OF COMPONENTS - TEILELISTE  
LISTE DES PIECES DETACHEES - LISTA DE PIEZAS

Tavola N°9D - Rev. 0

730098600

KIT PEDALIERA  
PEDALBOARD KIT  
PEDALSTEUERUNGSET  
KIT PEDALIER  
KIT PEDALERA

ROT. HP441.201102	ROT. HP641.200938	ROT. HP641.201034	ROT. HP641.200891	ROT. HP641.200785	ROT. HP641.201003	ROT. HP641.201788	ROT. HP641.201072	ROT. HP641.201065	ROT. HP641.201997	ROT. HP643.200984	ROT. HP643.201681	ROT. HP643.201133	ROT. HP643.200983	RAV. G7441.201140	RAV. G7441.200969	RAV. G7441.201119	RAV. G7441.200716	RAV. G7441.200877	RAV. G7441.200821	RAV. G7641.200945	RAV. G7641.200006	RAV. G7641.201041	RAV. G7641.200807	RAV. G7641.200689	RAV. G7641.201010	RAV. G7641.201089	RAV. G7641.200761	RAV. G7645.201232	RAV. G7645.200914	RAV. G7645.200990	RAV. G8645.201249	SFA. GA441.200976	SFA. GA441.201126	SFA. GA441.202000	SFA. GA641.201027	SFA. GA641.201096	SFA. GA641.200952	SFA. GA641.201058	SFA. GA645.200600
-------------------	-------------------	-------------------	-------------------	-------------------	-------------------	-------------------	-------------------	-------------------	-------------------	-------------------	-------------------	-------------------	-------------------	-------------------	-------------------	-------------------	-------------------	-------------------	-------------------	-------------------	-------------------	-------------------	-------------------	-------------------	-------------------	-------------------	-------------------	-------------------	-------------------	-------------------	-------------------	-------------------	-------------------	-------------------	-------------------	-------------------	-------------------	-------------------	-------------------

#		D.R	N	Descrizione	Description	Beschreibung	Description	Descripción	→	→
---	---	-----	---	-------------	-------------	--------------	-------------	-------------	---	---

1	✓		B2850001	Blocchetto a 5 vie	5-way block	5-Wege-Blöckchen	Petit block à 5 votes	Bloque a 5 vías		
2	✓		730026151	Corpo pedaliera	Pedalboard body	Pedalengehäuse	Corps pédalier	Cuerpo pedalera		
3	✓		140915170	Perno fulcro pedali	Pedals pivot pin	Drehpunktzapfen der Pedalen	Pivot point d'appui pédales	Perno fulcro pedales		
4	✓	10.0	140990391	Insieme pedale stallonatore	Bead breaker pedal assembly	Abdrückpedalsatz	Ensemble pédale décolle-pneus	Conjunto pedal destalonador		
5	✓	13C.0	730098640	Pedale rotazione mandrino	Chuck rotation pedal	Spindeldrehungspedal	Pédale de rotation mandrin	Pedal rotación mandril		
6	✓	11.0	140990401	Insieme pedale mandrino	Chuck pedal assembly	Spindelpedalsatz	Ensemble pédale mandrin	Conjunto pedal mandril		
7	✓	12.0	140990431	Gruppo pedale	Pedal assembly	Pedalsatz	Ensemble pédal	Conjunto pedal		
8	✓		238004	Rondella elastica 6,4	6.4 spring washer	Elastische Unterlagsscheibe 6,4	Rondelle elastique 6,4	Arandela elástica 6,4		
9	✓		251102	Inserto filettato	Threaded insert	Gewindeinsatz	Renfort fileté	Inserto roscado		
10	✓		271021	TBEI M6x20	TBEI M6x20 bolt	Schraube TBEI M6x20	Vis TBEI M6x20	Tornillo TBEI M6x20		
11	✓		299052	Anello di fermo D.9	D.9 stopper ring	Stoppring D.9	Anneau d'arrêt D.9	Anillo de seguro D.9		
12	✓		730070270	Kit sostituzione pedale	Pedal replacement kit	Set für Ersetzung des Pedals	Kit substitution pédale	Kit sustitución pedal		
13	✓		140915032	Pedale	Pedal	Pedal	Pédale	Pedal		
14	✓		140915020	Camma molla	Spring cam	Federnocken	Came ressort	Leva resorte		
15	✓		317007	Tube rilsan 8x6 nero	8x6 black rilsan hose	Rilsan Rohr 8x6 schwarz	Tuyau rilsan 8x6 noir	Tubo rilsan 8x6 negro		

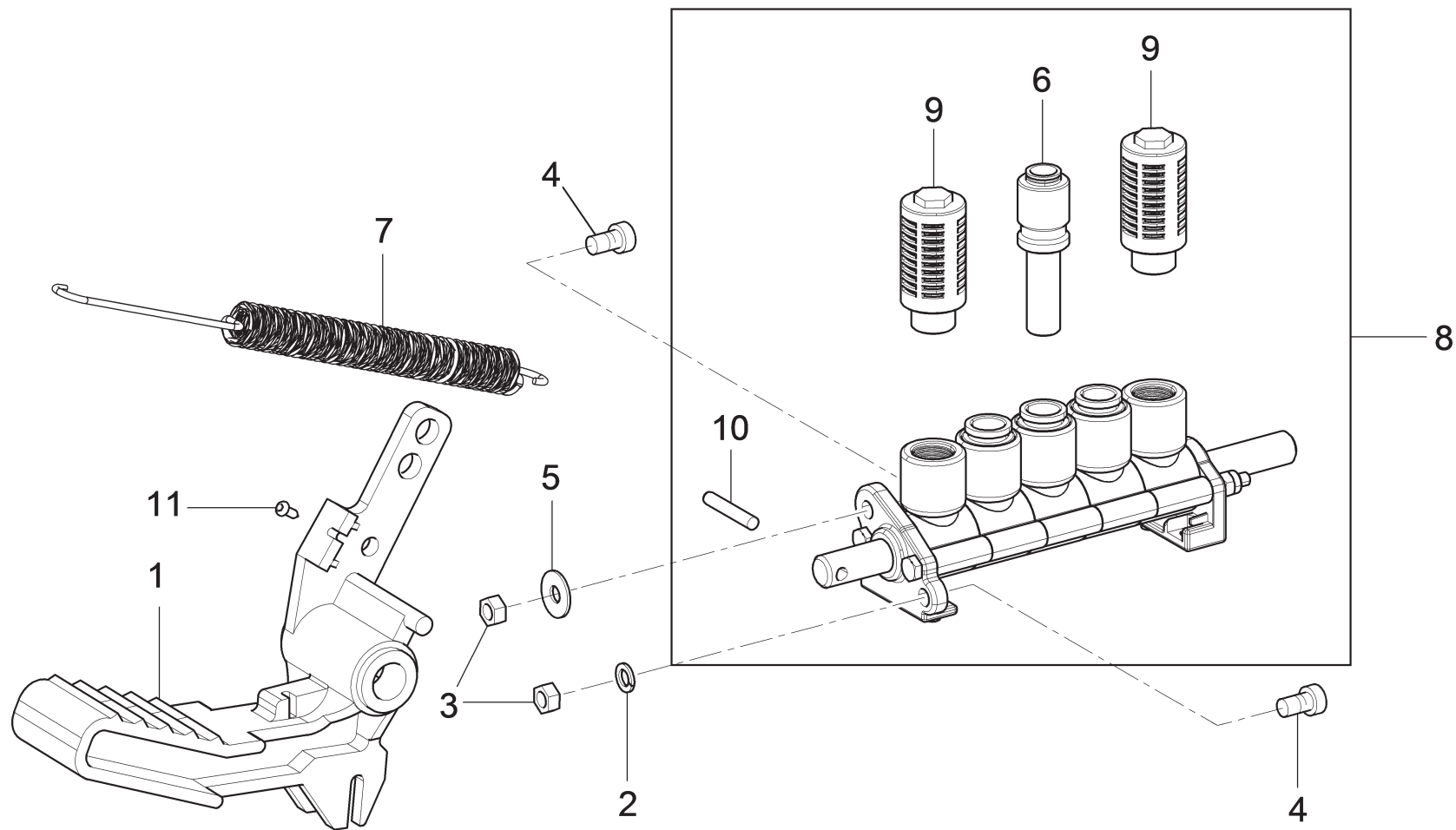

ROT.	HP441.201102	•	ROT.	HP641.200838	•	ROT.	HF641.201034	•	ROT.	HP641.200891	•	ROT.	HF641.200785	•	ROT.	HP641.201072	•	ROT.	HF641.201065	•	ROT.	HP641.201897	•	ROT.	HP643.200894	•	ROT.	HP643.201181	•	ROT.	HP643.201133	•	ROT.	HF643.200983	•	RAV.	G7441.201140	•	RAV.	G7441.200969	•	RAV.	G7441.201119	•	RAV.	G7441.200716	•	RAV.	G7441.200877	•	RAV.	G7441.200821	•	RAV.	G7641.200945	•	RAV.	G7641.200006	•	RAV.	G7641.201041	•	RAV.	G7641.200907	•	RAV.	G7641.200683	•	RAV.	G7641.201010	•	RAV.	G7641.201089	•	RAV.	G7641.200761	•	RAV.	G7645.201232	•	RAV.	G7645.200914	•	RAV.	G7645.200990	•	RAV.	G8645.201249	•	SFA.	GA441.200976	•	SFA.	GA441.201126	•	SFA.	GA441.202000	•	SFA.	GA641.201027	•	SFA.	GA641.201096	•	SFA.	GA641.200952	•	SFA.	GA641.201058	•	SFA.	GA645.200600	•
------	--------------	---	------	--------------	---	------	--------------	---	------	--------------	---	------	--------------	---	------	--------------	---	------	--------------	---	------	--------------	---	------	--------------	---	------	--------------	---	------	--------------	---	------	--------------	---	------	--------------	---	------	--------------	---	------	--------------	---	------	--------------	---	------	--------------	---	------	--------------	---	------	--------------	---	------	--------------	---	------	--------------	---	------	--------------	---	------	--------------	---	------	--------------	---	------	--------------	---	------	--------------	---	------	--------------	---	------	--------------	---	------	--------------	---	------	--------------	---	------	--------------	---	------	--------------	---	------	--------------	---	------	--------------	---	------	--------------	---	------	--------------	---	------	--------------	---	------	--------------	---



LISTA DEI COMPONENTI - LIST OF COMPONENTS - TEILELISTE  
 LISTE DES PIÈCES DÉTACHÉES - LISTA DE PIEZAS

Tavola N°10 - Rev. 0

140990391

INSIEME PEDALE STALLONATORE  
 BEAD BREAKER PEDAL ASSEMBLY  
 ABRÜCKPEDALSATZ  
 ENSEMBLE PÉDALE DÉCOLLE-PNEUS  
 CONJUNTO PEDAL DESTALONADOR







LISTA DEI COMPONENTI - LIST OF COMPONENTS - TEILELISTE  
 LISTE DES PIECES DETACHEES - LISTA DE PIEZAS

INSIEME PEDALE MANDRINO  
 CHUCK PEDAL ASSEMBLY  
 SPINDEL PEDALSATZ  
 ENSEMBLE PÉDALE MANDRIN  
 CONJUNTO PEDAL MANDRIL

Tavola N°11 - Rev. 0

140990401

ROT. HP441.201102	ROT. HP641.200938	ROT. HP641.201034	ROT. HP641.200891	ROT. HP641.200785	ROT.HP641.201003	ROT.HP641.201788	ROT. HP641.201072	ROT. HP641.201065	ROT. HP641.201997	ROT.HP643.200984	ROT.HP643.201681	ROT. HP643.201133	ROT. HP643.200983	RAV. G7441.201140	RAV. G7441.200969	RAV. G7441.201119	RAV. G7441.200716	RAV. G7441.200877	RAV. G7441.200921	RAV. G7641.200945	RAV. G7641.200006	RAV. G7641.201041	RAV.G7641.200907	RAV.G7641.200689	RAV. G7641.201010	RAV. G7641.201089	RAV. G7641.200761	RAV. G7645.201232	RAV. G7645.200914	RAV. G7645.200990	RAV. G8645.201249	SFA. GA441.200976	SFA. GA441.201126	SFA. GA441.202000	SFA. GA641.201027	SFA. GA641.201096	SFA. GA641.200952	SFA. GA641.201058	SFA. GA645.200600						
●	●	●	●	●	●	●	●	●	●	●	●	●	●	●	●	●	●	●	●	●	●	●	●	●	●	●	●	●	●	●	●	●	●	●	●	●	●	●	●	●	●	●	●	●	●
#		D.R	N	Descrizione		Description		Beschreibung		Description			Descripción																																

1	✓		140915032	Pedale	Pedal	Pedal	Pédale	Pedal																																																	
2	✓		950001720	Molla invertitore	Inverter spring	Frequenzumformerfeder	Ressort inverseur	Resorte inversor																																																	
3	✓		140915101	Camma comando valvole	Valve control cam	Ventilssteuerungsnocke	Came commande soupapes	Leva comando válvula																																																	
4	✓		140915111	Copertura camma	Cam cover	Nockenabdeckung	Couverture came	Cobertura leva																																																	
5	✓		140915161	Insieme levetta	Lever assembly	Hebelsatz	Ensemble levier	Conjunto palanca																																																	
6	✓		234036	Spina cilindrica	Cylindrical pin	Zylinderszapfen	Goupille cylindrique	Clavija cilíndrica																																																	
7	✓		237011	Rondella piana ø6x18	ø6x18 flat washer	Ebene Unterlagsscheibe ø6x18	Rondelle plane ø6x18	Arandela plana ø6x18																																																	
8	✓		239019	Rondella dentata 6,4	6.4 toothed washer	Zahnunterlagscheibe 6,4	Rondelle dentée 6,4	Arandela dentada 6,4																																																	
9	✓		206096	TCEI M6x45	TCEI M6x45 bolt	Schraube TCEI M6x45	Vis TCEI M6x45	Tornillo TCEI M6x45																																																	
10	✓		206007	TCEI M5x14	TCEI M5x14 bolt	Schraube TCEI M5x14	Vis TCEI M5x14	Tornillo TCEI M5x14																																																	
11	✓		140998071	Insieme distributore mandrino	Chuck distributor assembly	Spindelsvertelersatz	Ensemble distributeur mandrin	Conjunto distribuidor mandril																																																	
12	✓		238026	Rondella elastica 5,3	5.3 spring washer	Elastische Unterlagsscheibe 5,3	Rondelle élastique 5,3	Arandela elástica 5,3																																																	
13	✓		224005	Dado medio M5	M5 med nut	Mittlere Mutter M5	Écrou moyen M5	Tuerca media M5																																																	
14	✓		237010	Rondella piana 5,5x20x1,5	5x20x1.5 washer	Ebene Unterlagsscheibe 5x20x1,5	Rondelle 5x20x1,5	Arandela 5x20x1,5																																																	
15	✓		140998090	Cartuccia	Cartridge	Kartusche	Cartouche	Cartucho																																																	
16	✓		399066	Silenziatore	Silencer	Schalldämpfer	Silencieux	Silenciador																																																	
17	✓		140915133	Spola	Spool	Spule	Bobine	Bobina																																																	





**LISTA DEI COMPONENTI - LIST OF COMPONENTS - TEILELISTE**  
**LISTE DES PIÈCES DÉTACHÉES - LISTA DE PIEZAS**

**Tavola N°12 - Rev. 0**

**140990431**

GRUPPO PEDALE  
 PEDAL ASSEMBLY  
 PEDALSATZ  
 ENSEMBLE PÉDAL  
 CONJUNTO PEDAL

ROT. HP441.201102	ROT. HP641.200938	ROT. HP641.201034	ROT. HP641.200891	ROT. HP641.200785	ROT. HP641.201003	ROT. HP641.201788	ROT. HP641.201072	ROT. HP641.201065	ROT. HP641.201997	ROT. HP643.200984	ROT. HP643.201681	ROT. HP643.201133	ROT. HP643.200983	RAV G7441.201140	RAV G7441.200969	RAV G7441.201119	RAV G7441.200716	RAV G7441.200877	RAV G7441.200921	RAV G7641.200945	RAV G7641.200006	RAV G7641.201041	RAV G7641.200907	RAV G7641.200689	RAV G7641.201010	RAV G7641.201089	RAV G7641.200761	RAV G7645.201232	RAV G7645.200914	RAV G7645.200990	RAV G8645.201249	SFA GA441.200976	SFA GA441.201126	SFA GA441.202000	SFA GAG41.201027	SFA GAG41.201096	SFA GAG41.200952	SFA GAG41.201058	SFA GAG45.200600			
•	•	•	•	•	•	•	•	•	•	•	•	•	•	•	•	•	•	•	•	•	•	•	•	•	•	•	•	•	•	•	•	•	•	•	•	•	•	•	•	•	•	•
#		D.R	N	Descrizione	Description	Beschreibung	Description	Descripción	▶		▶																															

1	✓		224005	Dado medio M5	M5 med nut	Mittlere Mutter M5	Écrou moyen M5	Tuerca media M5				
2	✓		140998062	Insieme distributore ribaltamento	Tilting distributor assembly	Kippensverteilersatz	Ensemble distributeur renversement	Conjunto distribuidor vuelco				
3	✓		399264	Silenziatore regolabile 1/8"	1/8" adjustable silencer	Einstellbarschalldämpfer 1/8"	Silencieux réglable 1/8"	Silenciador regulable 1/8"				
4	✓		140915032	Pedale	Pedal	Pedal	Pédale	Pedal				
5	✓		950001720	Molla invertitore	Inverter spring	Frequenzumformerfeder	Ressort inverseur	Resorte inversor				
6	✓		234036	Spina cilindrica	Cylindrical pin	Zylinderszapfen	Goupille cylindrique	Clavija cilíndrica				
7	✓		140915133	Spola	Spool	Spule	Bobine	Bobina				
8	✓		140998090	Cartuccia	Cartridge	Kartusche	Cartouche	Cartucho				
9	✓		140915161	Insieme levetta	Lever assembly	Hebelsatz	Ensemble levier	Conjunto palanca				
10	✓		140915101	Camma comando valvole	Valve control cam	Ventilssteuerungsnocke	Came commande soupapes	Leva comando válvula				
11	✓		140915111	Copertura camma	Cam cover	Nockenabdeckung	Couverture came	Cobertura leva				
12	✓		206096	TCEI M6x45	TCEI M6x45 bolt	Schraube TCEI M6x45	Vis TCEI M6x45	Tornillo TCEI M6x45				
13	✓		239019	Rondella dentata 6,4	6.4 toothed washer	Zahnunterlagscheibe 6,4	Rondelle dentée 6,4	Arandela dentada 6,4				
14	✓		237011	Rondella piana ø6x18	ø6x18 flat washer	Ebene Unterlagsscheibe ø6x18	Rondelle plane ø6x18	Arandela plana ø6x18				
15	✓		206007	TCEI M5x14	TCEI M5x14 bolt	Schraube TCEI M5x14	Vis TCEI M5x14	Tornillo TCEI M5x14				
16	✓		238026	Rondella elastica 5,3	5.3 spring washer	Elastische Unterlagsscheibe 5,3	Rondelle élastique 5,3	Arandela elástica 5,3				
17	✓		237010	Rondella piana 5,5x20x1,5	5x20x1.5 washer	Ebene Unterlagsscheibe 5x20x1,5	Rondelle 5x20x1,5	Arandela 5x20x1,5				

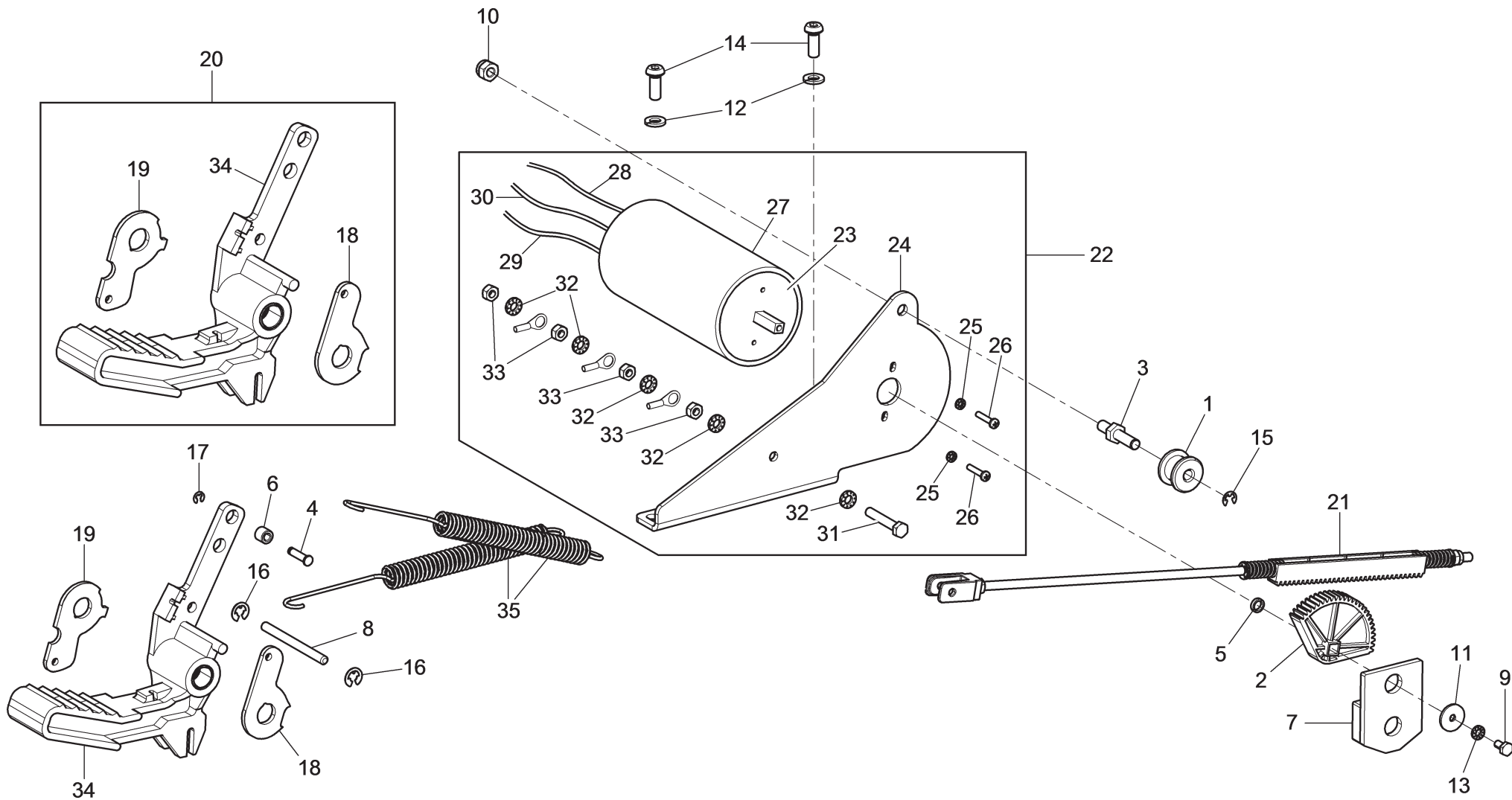

ROT. HP441.201102	ROT. HP641.200838	ROT. HP641.201034	ROT. HP641.200891	ROT. HP641.200785	ROT:HP641.201063	ROT:HP641.201788	ROT. HP641.201072	ROT. HP641.201065	ROT. HP641.201897	ROT:HP643.200894	ROT:HP643.201881	ROT. HP643.201133	ROT. HP643.200983	RAV. G7441.201140	RAV. G7441.200969	RAV. G7441.201119	RAV. G7441.200716	RAV. G7441.200877	RAV. G7441.200821	RAV. G7641.200945	RAV. G7641.200006	RAV. G7641.201041	RAV:G7641.200907	RAV:G7641.200683	RAV. G7641.201010	RAV. G7641.201089	RAV. G7641.200761	RAV. G7645.201232	RAV. G7645.200914	RAV. G7645.200990	RAV. G8645.201249	SFA. GA441.200976	SFA. GA441.201126	SFA. GA441.202000	SFA. GA641.201027	SFA. GA641.201096	SFA. GA641.200952	SFA. GA641.201058	SFA. GA645.200600			
•					•		•	•	•						•	•	•	•						•	•	•										•	•	•				
		<b>LISTA DEI COMPONENTI - LIST OF COMPONENTS - TEILELISTE</b> <b>LISTE DES PIÈCES DÉTACHÉES - LISTA DE PIEZAS</b>																			PEDALE PEDAL PEDAL PÉDALE PEDAL																					
		<b>Tavola N°13A - Rev. 0</b>					<b>730098310</b>					<b>Pag. 104 di 235</b>																														

ROT. HP441.201102	ROT. HP641.200938	ROT. HP641.201034	ROT. HP641.200891	ROT. HP641.200785	ROT. HP641.201003	ROT. HP641.201788	ROT. HP641.201072	ROT. HP641.201065	ROT. HP641.201997	ROT. HP643.200984	ROT. HP643.201681	ROT. HP643.201133	ROT. HP643.200983	RAV. G7441.201140	RAV. G7441.200969	RAV. G7441.201119	RAV. G7441.200716	RAV. G7441.200877	RAV. G7441.200921	RAV. G7641.200945	RAV. G7641.200006	RAV. G7641.201041	RAV. G7641.200907	RAV. G7641.200889	RAV. G7641.201010	RAV. G7641.201089	RAV. G7641.200761	RAV. G7645.201232	RAV. G7645.200914	RAV. G7645.200990	RAV. G8645.201249	SFA. GA441.200976	SFA. GA441.201126	SFA. GA441.202000	SFA. GA641.201027	SFA. GA641.201096	SFA. GA641.200952	SFA. GA641.201058	SFA. GA645.200600	
●				●	●	●	●	●	●					●	●	●	●	●	●					●	●	●							●	●	●	●				
#		D.R	N	Descrizione	Description	Beschreibung	Description	Descripción																																

1	✓		B3837000	Rullo cremagliera	Rack roller	Zahnstangenrolle	Rouleau cremailière	Rodillo cremallera			
2	✓		B3838000	Settore dentato 6x6	6x6 toothed sector	Zahnbereich 6x6	Secteur denté 6x6	Sector dentado 6x6			
3	✓		B3934000	Perno per rullo	Pin for roller	Zapfen für Rolle	Pivot pour rouleau	Perno para rodillo			
4	✓		B5165000	Perno per forcella	Pin for fork	Zapfen für Gabel	Pivot pour fourche	Perno para horquilla			
5	✓		140816840	Distanziale	Spacer	Abstandsstück	Entretoise	Distanciadador			
6	✓		140912020	Boccola bronzo	Brass bushing	Messingbüchse	Douille de laiton	Casquillo de latón			
7	✓		140912050	Contrappeso pedaliera	Pedalboard counter weight	Pedalsteuerungsgegengewicht	Contre-poids pédalier	Contrapeso pedalera			
8	✓		140915040	Perno	Pin	Zapfen	Pivot	Perno			
9	✓		203228	TE M4x8	TE M4x8 bolt	Schraube TE M4x8	Vis TE M4x8	Tornillo TE M4x8			
10	✓		228010	Dado autobloccante M6	M6 self-locking nut	Selbstsichernde Mutter M6	Écrou auto-bloquant M6	Tuerca autobloccante M6			
11	✓		237021	Rondella tranciante	Washer	Schneidscheibe	Rondelle tronçonneuse	Arandela cizalla			
12	✓		238004	Rondella elastica 6,4	6.4 spring washer	Elastische Unterlagsscheibe 6,4	Rondelle elastique 6,4	Arandela elástica 6,4			
13	✓		239018	Rosetta dentata 4,3	4.3 toothed washer	Zahnscheibe 4,3	Rondelle dentée 4,3	Arandela dentada 4,3			
14	✓		266019	TBEI M6x16	TBEI M6x16 bolt	Schraube TBEI M6x16	Vis TBEI M6x16	Tornillo TBEI M6x16			
15	✓		299042	Anello di fermo D.4	D.4 stopper ring	Stoppring D.4	Anneau d'arrêt D.4	Anillo de seguro D.4			
16	✓		299132	Anello di fermo D.5	D.5 stopper ring	Stoppring D.5	Anneau d'arrêt D.5	Anillo de seguro D.5			
17	✓		299151	Anello 3,2	3.2 ring	Ring 3,2	Anneau 3,2	Anillo 3,2			
18	✓		730029190	Camma superiore	Upper cam	Obere Nocke	Came supérieure	Leva superior			
19	✓		730029200	Camma inferiore	Lower cam	Untere Nocke	Came inférieure	Leva inferior			
20	✓		730070650	Kit sostituzione pedale	Pedal replacement kit	Set für Ersetzung des Pedals	Kit substitution pédale	Kit sustitución pedal			
21	✓		730094010	Asta comando commutatore	Commutator control rod	Umschalterstange	Tige de commande commutateur	Barra mando conmutador			
22	✓		730098320	Montaggio commutatore 3 Ph 2 velocità 32 A	3 Ph 2-speed 32 A commutator assembly	Montage des Umschalters 3 Ph 2-Geschwindigkeiten 32 A	Montage commutateur 3 Ph 2-vitesses 32 A	Montaje conmutador 3 Ph 2-velocidades 32 A			
23	✓		518289	Commutatore	Commutator	Umschalter	Commutateur	Conmutador			
24	✓		730023771	Supporto commutatore	Commutator support	Umschaltershalterung	Support commutateur	Soporte conmutador			
25	✓		239028	Rondella dentata	Toothed washer	Zahnunterlagscheibe	Rondelle dentée	Arandela dentada			
26	✓		270319	TCB M3x16	TCB M3x16 bolt	Schraube TCB M3x16	Vis TCB M3x16	Tornillo TCB M3x16			
27	✓		518290	Protezione	Guard	Gehäuse	Protection	Cárter			
28	✓		730065330	Insieme cavo di alimentazione	Supply cable assembly	Speisungskabelsatz	Ensemble câble alimentation	Conjunto cable alimentación			
29	✓		730065340	Insieme cavo motore	Motor cable assembly	Motorkabelsatz	Ensemble câble moteur	Conjunto cable motor			
30	✓		790065110	Cavo di terra	Ground cable	Erdkabel	Câble de masse	Cable tierra			
31	✓		203124	TE M5x30	TE M5x30 bolt	Schraube TE M5x30	Vis TE M5x30	Tornillo TE M5x30			
32	✓		239017	Rosetta	Washer	Unterlegscheibe	Rondelle	Arandela			



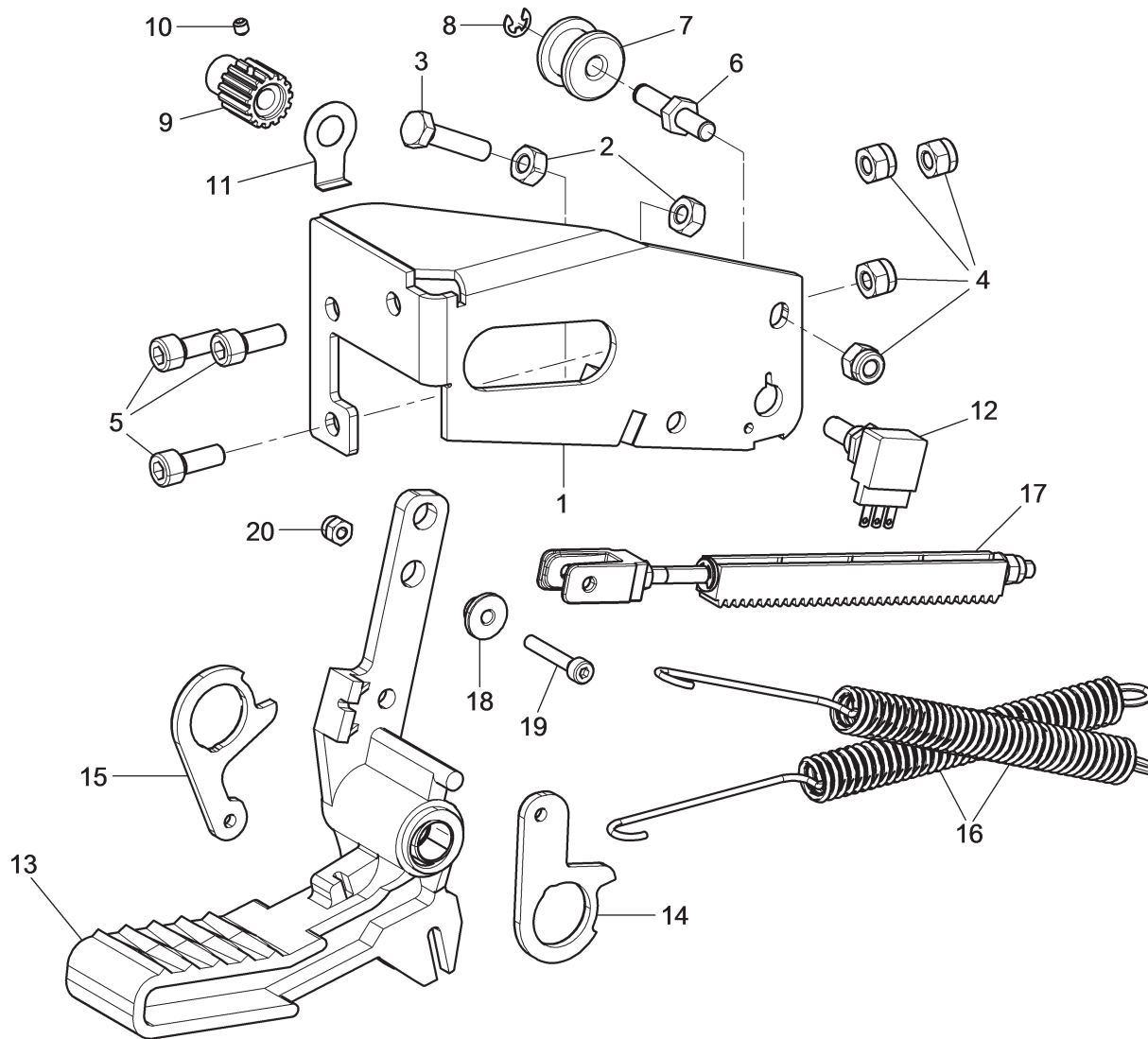

ROT. HP441.201102	•	ROT. HP641.200838	•	ROT. HF641.201034	•	ROT. HP641.200891	•	ROT. HF641.200785	•	ROT:HP641.201063		ROT:HP641.201788		ROT. HF641.201072		ROT. HF641.201065		ROT. HF641.201897		ROT:HP643.200894	•	ROT:HP643.201881	•	ROT. HP643.201133	•	ROT. HF643.200983	•	RAV. G7441.201140		RAV. G7441.200969		RAV. G7441.201119		RAV. G7441.200716		RAV. G7441.200877		RAV. G7441.200821	•	RAV. G7641.200945	•	RAV. G7641.200006	•	RAV. G7641.201041	•	RAV:G7641.200907	•	RAV:G7641.200683		RAV. G7641.201010		RAV. G7641.201089		RAV. G7641.200761	•	RAV. G7645.201232	•	RAV. G7645.200914	•	RAV. G7645.200890	•	RAV. G8645.201249	•	SFA. GA441.200876		SPA. GA441.201126		SFA. GA441.202000		SFA. GA641.201027		SFA. GA641.201096		SFA. GA641.200952	•	SFA. GA641.201058	•	SFA. GA645.200600	•
<p style="text-align: center;"><b>LISTA DEI COMPONENTI - LIST OF COMPONENTS - TEILELISTE</b>  <b>LISTE DES PIÈCES DÉTACHÉES - LISTA DE PIEZAS</b></p>																												<p>GRUPPO PEDALE CON INVERTER          PEDAL ASSEMBLY WITH INVERTER          PEDALSATZ MIT FREQUENZUMFORMER          ENSEMBLE PÉDALE AVEC INVERSEUR          CONJUNTO PEDAL CON INVERSOR</p>				<p>▶</p> <p>▶</p>																																															
<b>Tavola N°13B - Rev. 0</b>														<b>730096820</b>														<b>Pag. 107 di 235</b>																																																			



Tavola N°13B - Rev. 0

730096820

ROT. HP441.201102	ROT. HP641.200938	ROT. HP641.201034	ROT. HP641.200891	ROT. HP641.200785	ROT. HP641.201003	ROT. HP641.201788	ROT. HP641.201072	ROT. HP641.201065	ROT. HP641.201997	ROT. HP643.200984	ROT. HP643.201681	ROT. HP643.201133	ROT. HP643.200983	RAV G7441.201140	RAV G7441.200969	RAV G7441.201119	RAV G7441.200716	RAV G7441.200877	RAV G7441.200921	RAV G7641.200945	RAV G7641.200006	RAV G7641.201041	RAV G7641.200807	RAV G7641.200889	RAV G7641.201010	RAV G7641.201089	RAV G7641.200761	RAV G7645.201232	RAV G7645.200914	RAV G7645.200990	RAV G8645.201249	SFA GA441.200976	SFA GA441.201126	SFA GA441.202000	SFA GA641.201027	SFA GA641.201096	SFA GA641.200952	SFA GA641.201058	SFA GA645.200600	
•	•	•	•	•							•	•	•							•	•								•	•	•					•	•	•		
#		D.R	N	Descrizione	Description	Beschreibung	Description	Descripción	→	→																														

1	✓		730028790	Supporto potenziometro	Potentiometer support	Potenzimetersträger	Support potentiomètre	Soporte potenciómetro		
2	✓		224007	Dado medio M6	M6 med nut	Mittlere Mutter M6	Écrou moyen M6	Tuerca media M6		
3	✓		203127	TE M6x25	TE M6x25 bolt	Schraube TE M6x25	Vis TE M6x25	Tornillo TE M6x25		
4	✓		228010	Dado autobloccante M6	M6 self-locking nut	Selbstsichernde Mutter M6	Écrou auto-bloquant M6	Tuerca autobloccante M6		
5	✓		206019	TCEI M6x16	TCEI M6x16 bolt	Schraube TCEI M6x16	Vis TCEI M6x16	Tornillo TCEI M6x16		
6	✓		B3934000	Perno per rullo	Pin for roller	Zapfen für Rolle	Pivot pour rouleau	Perno para rodillo		
7	✓		B3837000	Rullo cremagliera	Rack roller	Zahnstangenrolle	Rouleau crémaillère	Rodillo cremallera		
8	✓		299042	Anello di fermo D.4	D.4 stopper ring	Stoppring D.4	Anneau d'arrêt D.4	Anillo de seguro D.4		
9	✓		730011050	Pignone D.17	D.17 pinion gear	Ritzel D.17	Pignon D.17	Piñon D.17		
10	✓		213485	STEI M4x4	STEI M4x4 bolt	Schraube STEI M4x4	Vis STEI M4x4	Tornillo STEI M4x4		
11	✓		790011970	Rosetta di sicurezza	Safety washer	Sicherungsscheibe	Rondelle de sécurité	Arandela de seguridad		
12	✓		710565010	Cavo e potenziometro	Cable and potentiometer	Kabel und Potenziometer	Câble et potentiomètre	Cable y potenciómetro		
13	✓		730091391	Pedale con boccole	Pedal with bushings	Pedal mit Büchsen	Pédale avec douilles	Pedal con casquillos		
14	✓		730017980	Camma	Cam	Nocke	Came	Leva		
15	✓		730017990	Camma	Cam	Nocke	Came	Leva		
16	✓		950001720	Molla invertitore	Inverter spring	Frequenzumformerfeder	Ressort inverseur	Resorte inversor		
17	✓		730091040	Cremagliera	Rack	Zahnstange	Crémaillère	Cremallera		
18	✓		730012310	Pastiglia	Plug nut	Belag	Pastille	Pastilla		
19	✓		206231	TCEI M4x25	TCEI M4x25 bolt	Schraube TCEI M4x25	Vis TCEI M4x25	Tornillo TCEI M4x25		





LISTA DEI COMPONENTI - LIST OF COMPONENTS - TEILELISTE  
LISTE DES PIÈCES DÉTACHÉES - LISTA DE PIEZAS

PEDALE ROTAZIONE MANDRINO  
CHUCK ROTATION PEDAL  
SPINDEL DREHUNGSPEDAL  
PÉDALE DE ROTATION MANDRIN  
PEDAL ROTACIÓN MANDRIL

Tavola N°13C - Rev. 0

730098640

#	D.R	N	Descrizione	Description	Beschreibung	Description	Descripción
1	✓	140915020	Camma molla	Spring cam	Federnocken	Came ressort	Leva resorte
2	✓	140915032	Pedale	Pedal	Pedal	Pédale	Pedal
3	✓	140915040	Perno	Pin	Zapfen	Pivot	Perno
4	✓	140915050	Insieme tirante piegato	Bent tie rod assembly	Gebogener Zugstangensatz	Ensemble tirant plié	Conjunto tirante doblado
5	✓	730098630	Insieme inverter trifase	3 Ph inverter assembly	3 Ph Frequenzumformerssatz	Ensemble inverseur 3 Ph	Conjunto inductor 3 Ph
6	✓	140310191	Attacco interruttore	Switch coupling	Anschluss Schalter	Branchement interrupteur	Conexión interruptor
7	✓	730029081	Lamiera supporto inverter	Inverter support plate	Frequenzumformer-Trägerblech	Tôle de support inverseur	Chapa soporte inductor
8	✓	518058	Insieme inverter trifase 1 velocità	1-speed 3 Ph inverter assembly	Frequenzumformerssatz 3 Ph 1-Geschwindigkeit	Ensemble inverseur 3 Ph 1-vitesse	Conjunto inductor 3 Ph 1-velocidad
9	✓	730065360	Insieme cavo motore	Motor cable assembly	Motorkabelsatz	Ensemble câble moteur	Conjunto cable motor
10	✓	730065350	Insieme cavo di alimentazione	Supply cable assembly	Speisungskabelsatz	Ensemble câble alimentation	Conjunto cable alimentación
11	✓	216194	TC M4x16	TC M4x16 bolt	Schraube TC M4x16	Vis TC M4x16	Tornillo TC M4x16
12	✓	238025	Rondella elastica 4,3	4.3 spring washer	Elastische Unterlagsscheibe 4,3	Rondelle elastique 4,3	Arandela elástica 4,3
13	✓	206233	TCEI M3x8	TCEI M3x8 bolt	Schraube TCEI M3x8	Vis TCEI M3x8	Tornillo TCEI M3x8
14	✓	239028	Rondella dentata	Toothed washer	Zahnunterlagsscheibe	Rondelle dentée	Arandela dentada
15	✓	790065110	Cavo di terra	Ground cable	Erdkabel	Câble de masse	Cable tierra
16	✓	203124	TE M5x30	TE M5x30 bolt	Schraube TE M5x30	Vis TE M5x30	Tornillo TE M5x30
17	✓	239017	Rosetta	Washer	Unterlegscheibe	Rondelle	Arandela
18	✓	224005	Dado medio M5	M5 med nut	Mittlere Mutter M5	Écrou moyen M5	Tuerca media M5
19	✓	230031	Copiglia 2,5x15	2.5x15 split pin	Splint 2,5x15	Goupille d'arrêt 2,5x15	Pasador 2,5x15
20	✓	236006	Rondella piana 8,4	8.4 flat washer	Ebene Unterlagsscheibe 8,4	Rondelle plane 8,4	Arandela plana 8,4
21	✓	238004	Rondella elastica 6,4	6.4 spring washer	Elastische Unterlagsscheibe 6,4	Rondelle elastique 6,4	Arandela elástica 6,4
22	✓	203019	TE M6x16	TE M6x16 bolt	Schraube TE M6x16	Vis TE M6x16	Tornillo TE M6x16
23	✓	299132	Anello di fermo D.5	D.5 stopper ring	Stoppring D.5	Anneau d'arrêt D.5	Anillo de seguro D.5
24	✓	950001720	Molla inverter	Inverter spring	Frequenzumformerfeder	Ressort inverseur	Resorte inductor

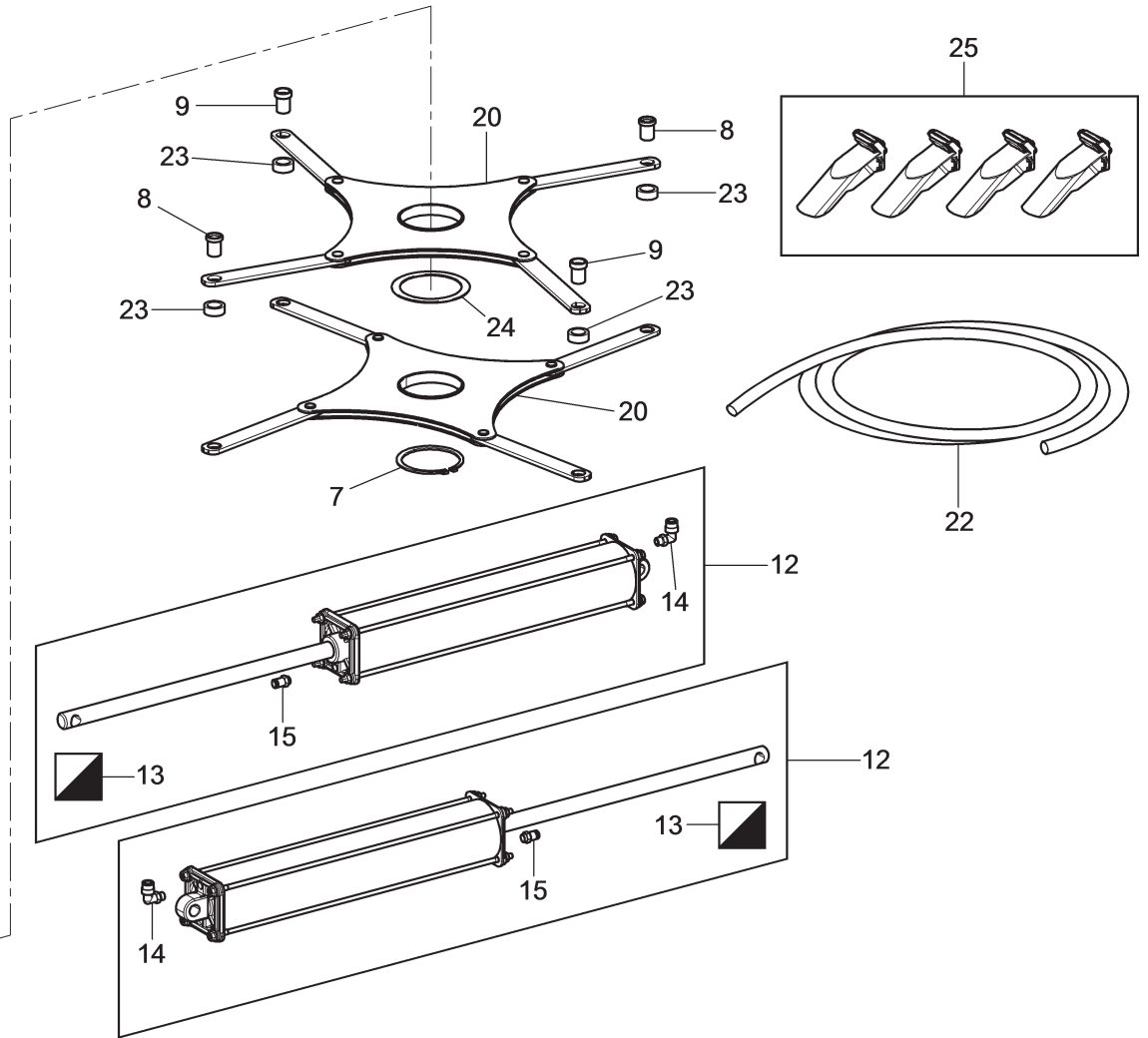
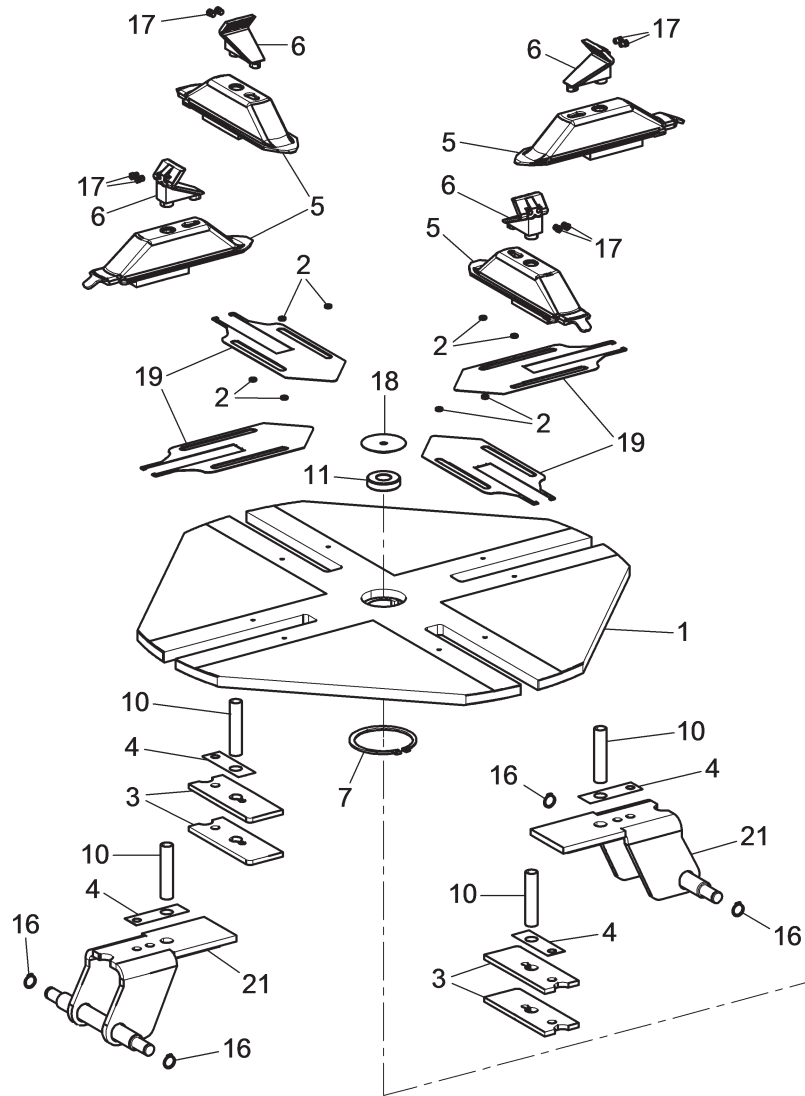

ROT. HP441.201102	ROT. HP641.200838	ROT. HP641.201034	ROT. HP641.200891	ROT. HP641.200785	ROT. HP641.201003	ROT. HP641.201788	ROT. HP641.201072	ROT. HP641.201065	ROT. HP641.201897	ROT. HP643.200894	ROT. HP643.201881	ROT. HP643.201133	ROT. HP643.200983	RAV. G7441.201140	RAV. G7441.200969	RAV. G7441.201119	RAV. G7441.200716	RAV. G7441.200877	RAV. G7441.200821	RAV. G7641.200945	RAV. G7641.200006	RAV. G7641.201041	RAV. G7641.200907	RAV. G7641.200683	RAV. G7641.201010	RAV. G7641.201089	RAV. G7641.200761	RAV. G7645.201232	RAV. G7645.200914	RAV. G7645.200990	RAV. G8645.201249	SFA. GA441.200976	SFA. GA441.201126	SFA. GA441.202000	SFA. GA641.201027	SFA. GA641.201096	SFA. GA641.200952	SFA. GA641.201058	SFA. GA645.200600						
•				•			•							•	•	•				•					•	•																			



LISTA DEI COMPONENTI - LIST OF COMPONENTS - TEILELISTE  
LISTE DES PIÈCES DÉTACHÉES - LISTA DE PIEZAS

Tavola N°14A - Rev. 0

730094620

MONTAGGIO MANDRINO QUADRO 10"-22"  
10"-22" SQUARE CHUCK ASSEMBLY  
MONTAGE DER QUADRATISCHEN SPINDEL 10"-22"  
MONTAGE MANDRIN CARRÉ 10"-22"  
MONTAJE MANDRIL CUADRADO 10"-22"

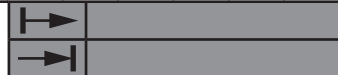

Pag. 111 di 235

Tavola N°14A - Rev. 0

730094620

ROT. HP441.201102	ROT. HP641.200938	ROT. HP641.201034	ROT. HP641.200891	ROT. HP641.200785	ROT. HP641.201003	ROT. HP641.201788	ROT. HP641.201072	ROT. HP641.201065	ROT. HP641.201997	ROT. HP643.200984	ROT. HP643.201681	ROT. HP643.201133	ROT. HP643.200983	RAV. G7441.201140	RAV. G7441.200969	RAV. G7441.201119	RAV. G7441.200716	RAV. G7441.200877	RAV. G7441.200921	RAV. G7641.200945	RAV. G7641.200006	RAV. G7641.201041	RAV. G7641.200907	RAV. G7641.200689	RAV. G7641.201010	RAV. G7641.201089	RAV. G7641.200761	RAV. G7645.201232	RAV. G7645.200914	RAV. G7645.200990	RAV. G8645.201249	SFA. GA441.200976	SFA. GA441.201126	SFA. GA441.202000	SFA. GAG41.201027	SFA. GAG41.201096	SFA. GAG41.200952	SFA. GAG41.201058	SFA. GAG45.200600				
●				●			●							●	●	●									●								●	●									
#		D.R	N	Descrizione	Description	Beschreibung	Description	Descripción																																			

1	✓		730024740	Insieme piatto quadro 10"-22"	10"-22" square plate assembly	Quadratische Platte Satz 10"-22"	Ensemble plateau carré 10"-22"	Conjunto plato cuadrado 10"-22"				
2	✓		140816840	Distanziale	Spacer	Abstandsstück	Entretoise	Distanciator				
3	✓		140815322	Piatto per guida slitta	Plate for slide guide	Schleifenführungsplatte	Plateau pour guide glissière	Placa para guía deslizadera				
4	✓		140816780	Spessore	Shim	Zwischenstück	Épaisseur	Espesor				
5	✓		730019880	Supporto griffa	Jaw support	Backenträger	Support griffe	Soporte garra				
6	✓		140815044	Griffa	Jaw	Backe	Griffe	Garra				
7	✓		243026	Seeger Ø 75	Clip ring Ø 75	Seeger Ø 75	Anneau de retenue Ø 75	Seeger Ø 75				
8	✓		730019310	Boccola motrice	Driving bushing	Antriebsbüchse	Douille motrice	Casquillo motor				
9	✓		730019190	Boccola condotta	Driven bushing	Geführte Büchse	Douille menée	Casquillo conducido				
10	✓		730017970	Tubino	Small hose	Kleines Rohr	Tuyau petit	Tubo pequeño				
11	✓		730023620	Rondella di bloccaggio	Locking washer	Sperrscheibe	Rondelle de blocage	Arandela de bloqueo				
12	✓		730094550	Montaggio cilindro pneumatico	Pneumatic cylinder assembly	Pneumatikzylindermontage	Montage cylindre pneumatique	Montaje cilindro neumático				
13	✓		GU4870	Kit guarnizione cilindro D.70	Cylinder gasket kit D.70	Zylinderdichtungenset D.70	Kit joint cylindre D.70	Kit junta cilindro D.70				
14	✓		325159	Raccordo a L	L-shaped fitting	L-Anschluss	Raccord à L	Empalme en L				
15	✓		325110	Raccordo	Fitting	Anschluss	Raccord	Empalme				
16	✓		243006	Seeger est.14 7435	External clip ring 14 7435	Externer Seeger 14 7435	Anneau de retenue extérieur 14 7435	Seeger externo 14 7435				
17	✓		730023440	Punta x griffa	Point for jaw	Spitze für Backe	Pointe pour griffe	Punta para garra				
18	✓		730023630	Tappo	Plug	Stöpsel	Bouchon	Tapón				
19	✓		730024410	Salvadita	Finger protection device	Handschutzeinrichtung	Dispositif protection doigts	Dispositivo protección ditas				
20	✓		730096210	Sincronizzatore 10-22	10-22 synchronizer	Synchronisierer 10-22	Synchroniseur 10-22	Sincronizador 10-22				
21	✓		730027890	Insieme cavallotto 10-22	10-22 U bolt assembly	U-förmige Bügelbolzensatz 10-22	Ensemble bride 10-22	Conjunto brida en forma de "u" 10-22				
22	✓		317038	Tubo Elastolan nero 8x5,5 L=2300	8x5.5 black Elastolan hose L=2300	Elastolan Rohr 8x5,5 schwarz L=2300	Tuyau Elastolan 8x5,5 noir L=2300	Tubo Elastolan 8x5,5 negro L=2300				
23	✓		730019290	Distanziale	Spacer	Abstandsstück	Entretoise	Distanciator				
24	✓		237547	Rondella 75x95x1	75x95x1 washer	Unterlagsscheibe 75x95x1	Rondelle 75x95x1	Arandela 75x95x1				
25	✓		770090190	Protezioni cerchi in lega	Standard clamp protections for alloy rims	Schutzgehäuse für Leichtmetallfelgen	Protection pour jantes en alliage	Protección para llantas de aleación				





LISTA DEI COMPONENTI - LIST OF COMPONENTS - TEILELISTE  
LISTE DES PIÉCES DÉTACHÉES - LISTA DE PIEZAS

MANDRINO QUADRO 10"-24"  
10"-24" SQUARE CHUCK  
QUADRATISCHE SPINDEL 10"-24"  
MANDRIN CARRÉ 10"-24"  
MANDRIL CUADRADO 10"-24"

Pag. 114 di 235

Tavola N°14B - Rev. 1

730095501

ROT. HP641.201102	ROT. HP641.200938	ROT. HP641.201034	ROT. HP641.200891	ROT. HP641.200785	ROT. HP641.201003	ROT. HP641.201788	ROT. HP641.201072	ROT. HP641.201065	ROT. HP641.201997	ROT. HP643.200984	ROT. HP643.201681	ROT. HP643.201133	ROT. HP643.200983	RAV. G7441.201140	RAV. G7441.200969	RAV. G7441.201119	RAV. G7441.200716	RAV. G7441.200877	RAV. G7441.200921	RAV. G7641.200945	RAV. G7641.200006	RAV. G7641.201041	RAV. G7641.200907	RAV. G7641.200689	RAV. G7641.201010	RAV. G7641.201089	RAV. G7641.200761	RAV. G7645.201232	RAV. G7645.200914	RAV. G7645.200990	RAV. G8645.201249	SFA. GA441.200976	SFA. GA441.201126	SFA. GA441.202000	SFA. GA641.201027	SFA. GA641.201096	SFA. GA641.200952	SFA. GA641.201058	SFA. GA645.200600		
	●		●	●					●											●	●		●																●		
#		D.R	N	Descrizione	Description	Beschreibung	Description	Descripción																																	

1	✓		140815322	Piatto per guida slitta	Plate for slide guide	Schlitzenführungsplatte	Plateau pour guide glissière	Placa para guía deslizadora				
2	✓		140816840	Distanziale	Spacer	Abstandsstück	Entretoise	Distanciadador				
3	✓		203108	TE M10x55	TE M10x55 bolt	Schraube TE M10x55	Vis TE M10x55	Tornillo TE M10x55				
4	✓		228006	Dado autobloccante M12	M12 self-locking nut	Selbstsichernde Mutter M12	Écrou auto-bloquant M12	Tuerca autobloccante M12				
5	✓		228022	Dado autobloccante basso M10	M10 jam self-locking nut	Untere selbstsichernde Mutter M10	Écrou auto-bloquant bas M10	Tuerca autobloccante baja M10				
6	✓		236007	Rondella piana 10,5x21x2	Fe 10,5x21x2 washer	Ebene Unterlagsscheibe 10,5x21x2	Rondelle Fe 10,5x21x2	Arandela Fe 10,5x21x2				
7	✓		236008	Rondella D.15	D.15 washer	Unterlagsscheibe D. 15	Rondelle D.15	Arandela D. 15				
8	✓		236011	Rondella piana 13	13 flat washer	Ebene Unterlagsscheibe 13	Rondelle plane 13	Arandela plana 13				
9	✓		237547	Rondella 75x95x1	75x95x1 washer	Unterlagsscheibe 75x95x1	Rondelle 75x95x1	Arandela 75x95x1				
10	✓		238007	Rondella elastica 10,5	10.5 spring washer	Elastische Unterlagsscheibe 10,5	Rondelle elastique 10,5	Arandela elástica 10,5				
11	✓		238011	Rondella elastica 13	13 spring washer	Elastische Unterlagsscheibe 13	Rondelle elastique 13	Arandela elástica 13				
12	✓		243006	Seeger est.14 7435	External clip ring 14 7435	Externer Seeger 14 7435	Anneau de retenue extérieur 14 7435	Seeger externo 14 7435				
13	✓		243026	Seeger Ø 75	Clip ring Ø 75	Seeger Ø 75	Anneau de retenue Ø 75	Seeger Ø 75				
14	✓		256256	TE M16x40	TE M16x40 bolt	Schraube TE M16x40	Vis TE M16x40	Tornillo TE M16x40				
15	✓		258077	TCEI M12x90	TCEI M12x90 bolt	Schraube TCEI M12x90	Vis TCEI M12x90	Tornillo TCEI M12x90				
16	✓		271950	Vite	Bolt	Schraube	Vis	Tornillo				
17	✓		317038	Tubo Elastolan nero 8x5,5 L=2500	8x5.5 black Elastolan hose L=2500	Elastolan Rohr 8x5,5 schwarz L=2500	Tuyau Elastolan 8x5,5 noir L=2500	Tubo Elastolan 8x5,5 negro L=2500				
18	✓		730019190	Boccola condotta	Driven bushing	Geführte Büchse	Douille menée	Casquillo conducido				
19	✓		730019290	Distanziale	Spacer	Abstandsstück	Entretoise	Distanciadador				
20	✓		730019310	Boccola motrice	Driving bushing	Antriebsbüchse	Douille motrice	Casquillo motor				
21	✓		730023440	Punta x griffa	Point for jaw	Spitze für Backe	Pointe pour griffe	Punta para garra				
22	✓		730023620	Rondella di bloccaggio	Locking washer	Sperrscheibe	Rondelle de blocage	Arandela de bloqueo				
23	✓		730023630	Tappo	Plug	Stöpsel	Bouchon	Tapón				
24	✓		730025981	Piatto saldato	Welded plate	Geschweißte Platte	Plateau soudé	Placa soldada				
25	✓		730026112	Salvadita 24"	24" finger protection device	Handschutzeinrichtung 24"	Dispositif protection doigts 24"	Dispositivo protección dítos 24"				
26	✓		730027760	Blocchetto	Block	Blöckchen	Petit bloc	Bloque				
27	✓		730027770	Tubino	Small hose	Kleines Rohr	Tuyau petit	Tubo pequeño				
28	✓		730027850	Insieme cavallotto	U bolt assembly	U-förmige Bügelbolzensatz	Ensemble bride en forme de U	Conjunto brida en forma de "u"				
29	✓		730026342	Griffa mandrino	Chuck jaw	Spindelbacke	Griffe mandrin	Garra mandril				
30	✓		730070392	Kit nuova griffa mandrino	Chuck new jaw kit	Set für neue Spindelbacke	Kit nouvelle griffe mandrin	Kit nueva garra mandril				



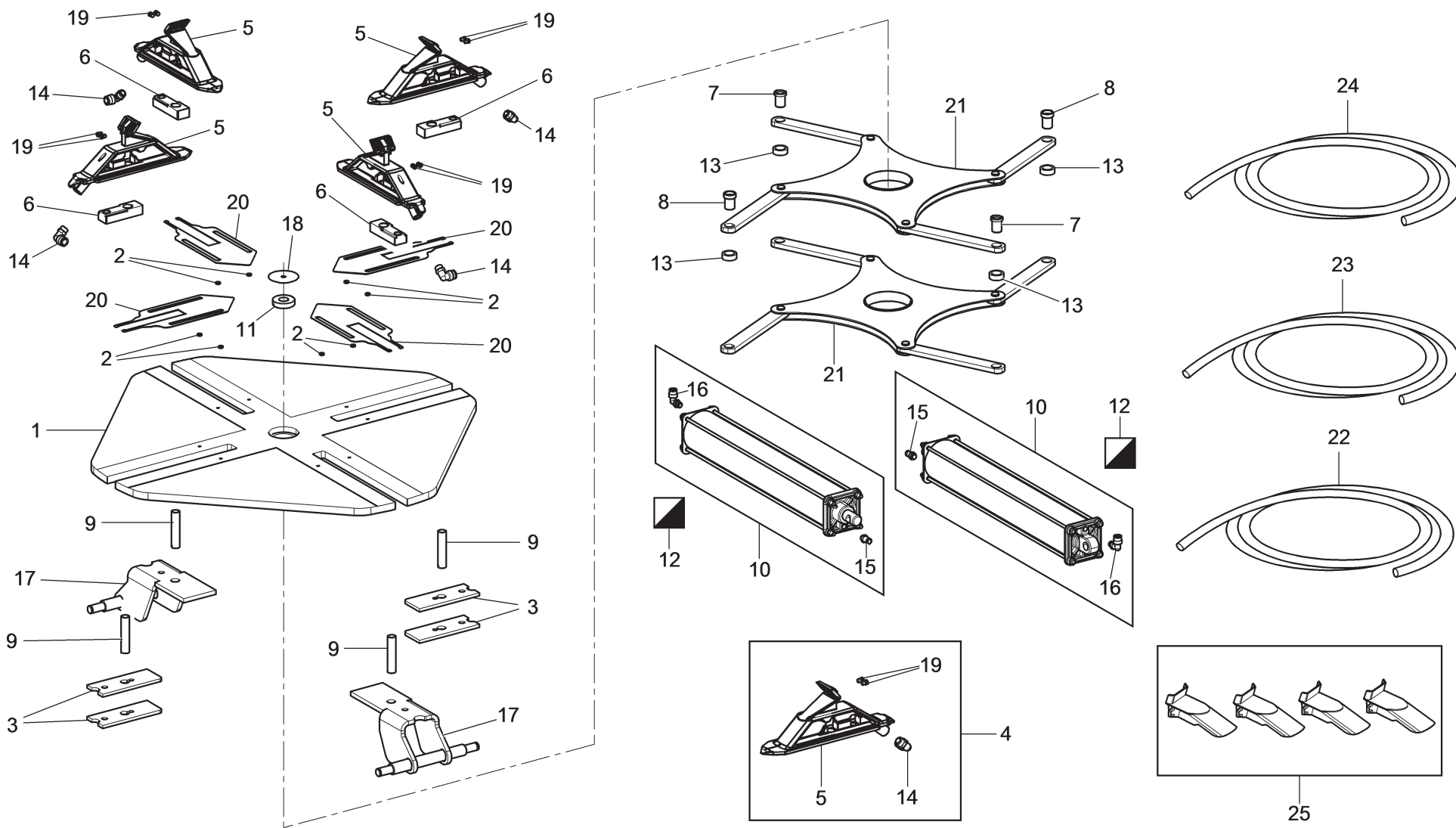

ROT. HP441.201102	ROT. HP641.200838	ROT. HP641.201034	ROT. HP641.200891	ROT. HP641.200785	ROT.HP641.201003	ROT.HP641.201788	ROT. HP641.201072	ROT. HP641.201065	ROT. HP641.201897	ROT.HP643.200894	ROT.HP643.201881	ROT. HP643.201133	ROT. HP643.200983	RAV. G7441.201140	RAV. G7441.200969	RAV. G7441.201119	RAV. G7441.200716	RAV. G7441.200877	RAV. G7441.200821	RAV. G7641.200945	RAV. G7641.200006	RAV. G7641.201041	RAV.G7641.200907	RAV.G7641.200683	RAV. G7641.201010	RAV. G7641.201089	RAV. G7641.200761	RAV. G7645.201232	RAV. G7645.200914	RAV. G7645.200990	RAV. G8645.201249	SFA. GA441.200976	SPA. GA441.201126	SFA. GA441.202000	SPA. GA641.201027	SFA. GA641.201096	SPA. GA641.200952	SPA. GA641.201058	SPA. GA645.200600							
			•																			•																							•	
		<b>LISTA DEI COMPONENTI - LIST OF COMPONENTS - TEILELISTE</b> <b>LISTE DES PIÈCES DÉTACHÉES - LISTA DE PIEZAS</b>												MONTAGGIO MANDRINO 10"-24" 10"-24" CHUCK ASSEMBLY MONTAGE DER SPINDEL 10"-24" MONTAGE MANDRIN 10"-24" MONTAJE MANDRIL 10"-24"										▶ ▶		<b>Pag. 116 di 235</b>																				
<b>Tavola N°14C - Rev. 0</b>												<b>730095491</b>																																		

		<b>LISTA DEI COMPONENTI - LIST OF COMPONENTS - TEILELISTE</b> <b>LISTE DES PIÈCES DÉTACHÉES - LISTA DE PIEZAS</b>										MONTAGGIO MANDRINO 10"-24" 10"-24" CHUCK ASSEMBLY MONTAGE DER SPINDEL 10"-24" MONTAGE MANDRIN 10"-24" MONTAJE MANDRIL 10"-24"										<b>Pag. 117 di 235</b>																			
		<b>Tavola N°14C - Rev. 0</b>					<b>730095491</b>																																		
ROT. HF641.201102	ROT. HF641.200938	ROT. HF641.201034	ROT. HF641.200891	ROT. HF641.200785	ROT. HF641.201003	ROT. HF641.201788	ROT. HF641.201072	ROT. HF641.201065	ROT. HF641.201997	ROT. HF643.200984	ROT. HF643.201681	ROT. HF643.201133	ROT. HF643.200983	RAV. G7441.201140	RAV. G7441.200969	RAV. G7441.201119	RAV. G7441.200716	RAV. G7441.200877	RAV. G7441.200921	RAV. G7641.200945	RAV. G7641.200006	RAV. G7641.201041	RAV. G7641.200907	RAV. G7641.200689	RAV. G7641.201010	RAV. G7641.201089	RAV. G7641.200761	RAV. G7645.201232	RAV. G7645.200914	RAV. G7645.200990	RAV. G8645.201249	SFA. GA441.200976	SFA. GA441.201126	SFA. GA441.202000	SFA. GA641.201027	SFA. GA641.201096	SFA. GA641.200952	SFA. GA641.201058	SFA. GA645.200600		
●																●																									
#		D.R	N	Descrizione	Description	Beschreibung	Description	Descripción																																	

1	✓		730025981	Piatto saldato	Welded plate	Geschweißte Platte	Plateau soudé	Placa soldada				
2	✓		140816840	Distanziale	Spacer	Abstandsstück	Entretoise	Distanciadador				
3	✓		140815322	Piatto per guida slitta	Plate for slide guide	Schlitzenführungsplatte	Plateau pour guide glissière	Placa para guía deslizadera				
4	✓		730070402	Kit nuova griffa mandrino	Chuck new jaw kit	Set für neue Spindelbacke	Kit nouvelle griffe mandrin	Kit nueva garra mandril				
5	✓		730026342	Griffa mandrino	Chuck jaw	Spindelbacke	Griffe mandrin	Garra mandril				
6	✓		730027760	Blocchetto	Block	Blöckchen	Petit bloc	Bloque				
7	✓		730019310	Boccola motrice	Driving bushing	Antriebsbüchse	Douille motrice	Casquillo motor				
8	✓		730019190	Boccola condotta	Driven bushing	Geführte Büchse	Douille menée	Casquillo conducido				
9	✓		730027770	Tubino	Small hose	Kleines Rohr	Tuyau petit	Tubo pequeño				
10	✓		730095510	Montaggio cilindro pneumatico	Pneumatic cylinder assembly	Pneumatikzylindermontage	Montage cylindre pneuma- tique	Montaje cilindro neumático				
11	✓		730023620	Rondella di bloccaggio	Locking washer	Sperrscheibe	Rondelle de blocage	Arandela de bloqueo				
12	✓		GU4870	Kit guarnizione cilindro D.70	Cylinder gasket kit D.70	Zylinderdichtungenset D.70	Kit joint cylindre D.70	Kit junta cilindro D.70				
13	✓		730019290	Distanziale	Spacer	Abstandsstück	Entretoise	Distanciadador				
14	✓		325107	Raccordo	Fitting	Anschluss	Raccord	Empalme				
15	✓		325110	Raccordo	Fitting	Anschluss	Raccord	Empalme				
16	✓		325159	Raccordo a L	L-shaped fitting	L-Anschluss	Raccord à L	Empalme en L				
17	✓		730027850	Insieme cavallotto	U bolt assembly	U-förmige Bügelbolzensatz	Ensemble bride en forme de U	Conjunto brida en forma de "u"				
18	✓		730023630	Tappo	Plug	Stöpsel	Bouchon	Tapón				
19	✓		730023440	Punta x griffa	Point for jaw	Spitze für Backe	Pointe pour griffe	Punta para garra				
20	✓		730026112	Salvadita 24"	24" finger protection device	Handschutzeinrichtung 24"	Dispositif protection doigts 24"	Dispositivo protección ditos 24"				
21	✓		730096200	Sincronizzatore	Synchronizer	Synchronisierer	Synchronisation	Sincronizador				
22	✓		317010	Tubo rilsan 10x8 nero L=1200	10x8 black rilsan hose L=1200	Rilsan Rohr 10x8 schwarz L=1200	Tuyau rilsan 10x8 noir L=1200	Tubo rilsan 10x8 negro L=1200				
23	✓		317021	Tubo Elastolan 10x8 nero L=1800	10x8 black Elastolan hose L=1800	Elastolan Rohr 10x8 schwarz L=1800	Tuyau Elastolan 10x8 noir L=1800	Tubo Elastolan 10x8 negro L=1800				
24	✓		317038	Tubo Elastolan nero 8x5,5 L=2500	8x5.5 black Elastolan hose L=2500	Elastolan Rohr 8x5,5 schwarz L=2500	Tuyau Elastolan 8x5,5 noir L=2500	Tubo Elastolan 8x5,5 negro L=2500				
25	✓		770090190	Protezioni cerchi in lega	Standard clamp protections for alloy rims	Schutzgehäuse für Leichtme- tallfelgen	Protection pour jantes en alliage	Protección para llantas de aleación				



ROT. HP441.201102	ROT. HP641.200938	ROT. HP641.201034	ROT. HP641.200891	ROT. HP641.200785	ROT. HP641.201003	ROT. HP641.201788	ROT. HP641.201072	ROT. HP641.201065	ROT. HP641.201997	ROT. HP643.200984	ROT. HP643.201681	ROT. HP643.201133	ROT. HP643.200983	RAV. G7441.201140	RAV. G7441.200969	RAV. G7441.201119	RAV. G7441.200716	RAV. G7441.200877	RAV. G7441.200921	RAV. G7641.200945	RAV. G7641.200006	RAV. G7641.201041	RAV. G7641.200907	RAV. G7641.200689	RAV. G7641.201010	RAV. G7641.201089	RAV. G7641.200761	RAV. G7645.201232	RAV. G7645.200914	RAV. G7645.200990	RAV. G8645.201249	SFA. GA441.200976	SFA. GA441.201126	SFA. GA441.202000	SFA. GA641.201027	SFA. GA641.201096	SFA. GA641.200952	SFA. GA641.201058	SFA. GA645.200600				
							●										●																				●		●				
<b>#</b>		<b>D.R</b>	<b>N</b>	<b>Descrizione</b>	<b>Description</b>	<b>Beschreibung</b>	<b>Description</b>	<b>Descripción</b>																																			

1	✓		730024740	Insieme piatto quadro 10"-22"	10"-22" square plate assembly	Quadratische Platte Satz 10"-22"	Ensemble plateau carré 10"-22"	Conjunto plato cuadrado 10"-22"		
2	✓		140816840	Distanziale	Spacer	Abstandsstück	Entretoise	Distanciadador		
3	✓		140815322	Piatto per guida slitta	Plate for slide guide	Schlittenführungsplatte	Plateau pour guide glissière	Placa para guía deslizadera		
4	✓		140816780	Spessore	Shim	Zwischenstück	Épaisseur	Espesor		
5	✓		730017941	Supporto griffa	Jaw support	Backenträger	Support griffe	Soporte garra		
6	✓		140815044	Griffa	Jaw	Backe	Griffe	Garra		
7	✓		243026	Seeger Ø 75	Clip ring Ø 75	Seeger Ø 75	Anneau de retenue Ø 75	Seeger Ø 75		
8	✓		730019310	Boccola motrice	Driving bushing	Antriebsbüchse	Douille motrice	Casquillo motor		
9	✓		730019190	Boccola condotta	Driven bushing	Geführte Büchse	Douille menée	Casquillo conducido		
10	✓		730017970	Tubino	Small hose	Kleines Rohr	Tuyau petit	Tubo pequeño		
11	✓		730023620	Rondella di bloccaggio	Locking washer	Sperrscheibe	Rondelle de blocage	Arandela de bloqueo		
12	✓		730094550	Montaggio cilindro pneumatico	Pneumatic cylinder assembly	Pneumatikzylindermontage	Montage cylindre pneumatique	Montaje cilindro neumático		
13	✓		GU4870	Kit guarnizione cilindro D.70	Cylinder gasket kit D.70	Zylinderdichtungenset D.70	Kit joint cylindre D.70	Kit junta cilindro D.70		
14	✓		325159	Raccordo a L	L-shaped fitting	L-Anschluss	Raccord à L	Empalme en L		
15	✓		325110	Raccordo	Fitting	Anschluss	Raccord	Empalme		
16	✓		243006	Seeger est.14 7435	External clip ring 14 7435	Externer Seeger 14 7435	Anneau de retenue extérieur 14 7435	Seeger externo 14 7435		
17	✓		730023440	Punta x griffa	Point for jaw	Spitze für Backe	Pointe pour griffe	Punta para garra		
18	✓		730023630	Tappo	Plug	Stöpsel	Bouchon	Tapón		
19	✓		730024410	Salvadita	Finger protection device	Handschutzeinrichtung	Dispositif protection doigts	Dispositivo protección ditos		
20	✓		730096210	Sincronizzatore 10-22	10-22 synchronizer	Synchronisierer 10-22	Synchroniseur 10-22	Sincronizador 10-22		
21	✓		730027890	Insieme cavallotto 10-22	10-22 U bolt assembly	U-förmige Bügelbolzensatz 10-22	Ensemble bride 10-22	Conjunto brida en forma de "u" 10-22		
22	✓		730019290	Distanziale	Spacer	Abstandsstück	Entretoise	Distanciadador		
23	✓		237547	Rondella 75x95x1	75x95x1 washer	Unterlagsscheibe 75x95x1	Rondelle 75x95x1	Arandela 75x95x1		
24	✓		325107	Raccordo	Fitting	Anschluss	Raccord	Empalme		
25	✓		317038	Tubo Elastolan nero 8x5,5 L=2300	8x5.5 black Elastolan hose L=2300	Elastolan Rohr 8x5,5 schwarz L=2300	Tuyau Elastolan 8x5,5 noir L=2300	Tubo Elastolan 8x5,5 negro L=2300		
26	✓		317010	Tubo rilsan 10x8 nero L=700	10x8 black rilsan hose L=700	Rilsan Rohr 10x8 schwarz L=700	Tuyau rilsan 10x8 noir L=700	Tubo rilsan 10x8 negro L=700		
27	✓		317021	Tubo Elastolan 10x8 nero L=3000	10x8 black Elastolan hose L=3000	Elastolan Rohr 10x8 schwarz L=3000	Tuyau Elastolan 10x8 noir L=3000	Tubo Elastolan 10x8 negro L=3000		
28	✓		770090190	Protezioni cerchi in lega	Standard clamp protections for alloy rims	Schutzgehäuse für Leichtmetallfelgen	Protection pour jantes en alliage	Protección para llantas de aleación		

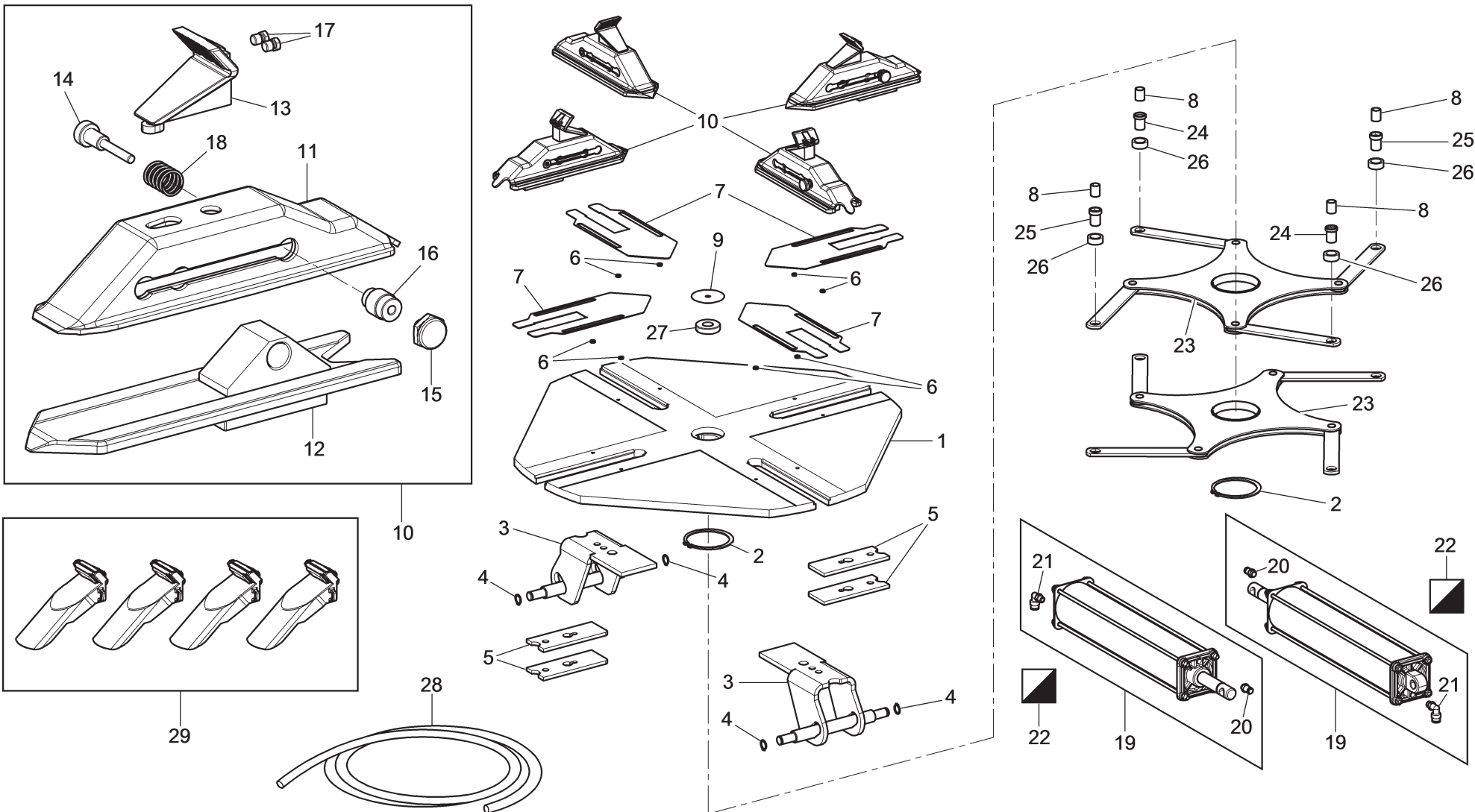

ROT. HP441.201102	ROT. HP641.200838	ROT. HF641.201034	ROT. HP641.200891	ROT. HF641.200785	ROT. HF641.201003	ROT. HF641.201788	ROT. HF641.201072	ROT. HF641.201065	ROT. HF641.201897	ROT. HF643.200684	ROT. HF643.201881	ROT. HF643.201133	ROT. HF643.200983	RAV. G7441.201140	RAV. G7441.200969	RAV. G7441.201119	RAV. G7441.200716	RAV. G7441.200877	RAV. G7441.200921	RAV. G7641.200945	RAV. G7641.200006	RAV. G7641.201041	RAV. G7641.200907	RAV. G7641.200683	RAV. G7641.201010	RAV. G7641.201089	RAV. G7641.200761	RAV. G7645.201232	RAV. G7645.200914	RAV. G7645.200990	RAV. G8645.201249	SFA. GA441.200976	SFA. GA441.201126	SFA. GA441.202000	SFA. GA641.201027	SFA. GA641.201096	SFA. GA641.200952	SFA. GA641.201058	SFA. GA645.200600				
											•		•																•														•



LISTA DEI COMPONENTI - LIST OF COMPONENTS - TEILELISTE  
 LISTE DES PIÈCES DÉTACHÉES - LISTA DE PIEZAS

Tavola N°14E - Rev. 0

730094811

MONTAGGIO MANDRINO 10"-26"  
 10"-26" CHUCK ASSEMBLY  
 MONTAGE DER SPINDEL 10"-26"  
 MONTAJE MANDRIN 10"-26"  
 MONTAJE MANDRIL 10"-26"

▶  
 ▶  
**Pag. 120 di 235**



LISTA DEI COMPONENTI - LIST OF COMPONENTS - TEILELISTE  
LISTE DES PIÈCES DÉTACHÉES - LISTA DE PIEZAS

Tavola N°14E - Rev. 0

730094811

MONTAGGIO MANDRINO 10"-26"  
10"-26" CHUCK ASSEMBLY  
MONTAGE DER SPINDEL 10"-26"  
MONTAGE MANDRIN 10"-26"  
MONTAJE MANDRIL 10"-26"

Pag. 121 di 235

#		D.R	N	Descrizione	Description	Beschreibung	Description	Descripción		
---	--	-----	---	-------------	-------------	--------------	-------------	-------------	--	--

1	✓		730024690	Insieme mandrino 10-26	10"-26" chuck assembly	Spindelsatz 10"-26"	Ensemble mandrin 10"-26	Conjunto mandril 10"-26"		
2	✓		243026	Seeger Ø 75	Clip ring Ø 75	Seeger Ø 75	Anneau de retenue Ø 75	Seeger Ø 75		
3	✓		730024600	Insieme cavallotto	U bolt assembly	U-förmige Bügelbolzensatz	Ensemble bride en forme de U	Conjunto brida en forma de "u"		
4	✓		243006	Seeger est.14 7435	External clip ring 14 7435	Externer Seeger 14 7435	Anneau de retenue extérieur 14 7435	Seeger esterno 14 7435		
5	✓		140815322	Piatto per guida slitta	Plate for slide guide	Schlittenführungsplatte	Plateau pour guide glissière	Placa para guía deslizadora		
6	✓		140816840	Distanziale	Spacer	Abstandsstück	Entretoise	Distanciator		
7	✓		730028940	Salvadita 10"-26"	10"-26" finger protection device	Handschutzeinrichtung 10"-26"	Dispositif protection doigts 10"-26"	Dispositivo protección ditos 10"-26"		
8	✓		140816230	Tubino	Small hose	Kleines Rohr	Tuyau petit	Tubo pequeño		
9	✓		730023630	Tappo	Plug	Stöpsel	Bouchon	Tapón		
10	✓		730095660	Insieme slitta assemblata	Assembled slide assembly	Assemblierter Schlittensatz	Ensemble coulisseau assemblé	Conjunto deslizadora montada		
11	✓		730026270	Slitta saldata	Welded slide	Geschweißter Schlitten	Coulisseau soudé	Deslizadora soldada		
12	✓		730028490	Piastra	Plate	Platte	Plaque	Placa		
13	✓		140816221	Griffa	Jaw	Backe	Griffe	Garra		
14	✓		730023531	Riposizionatore	Repositioner	Wiederstellungsregler	Repositionneur	Reposicionador		
15	✓		730021330	Pulsante	Push-button	Knopf	Poussoir	Pulsador		
16	✓		730021341	Perno riposizionatore	Repositioner pin	Wiederstellungsreglerzapfen	Pivot repositionneur	Perno reposicionador		
17	✓		730023440	Punta x griffa	Point for jaw	Spitze für Backe	Pointe pour griffe	Punta para garra		
18	✓		918037	Molla a compressione 1.5X15.5X20x5	Compression spring 1.5X15.5X20x5	Druckfeder 1.5X15.5X20x5	Ressort de compression 1.5X15.5X20x5	Resorte de compresión 1.5X15.5X20x5		
19	✓		730096900	Montaggio cilindro pneumatico	Pneumatic cylinder assembly	Pneumatikzylindermontage	Montage cylindre pneumatique	Montaje cilindro neumático		
20	✓		325110	Raccordo	Fitting	Anschluss	Raccord	Empalme		
21	✓		325159	Raccordo a L	L-shaped fitting	L-Anschluss	Raccord à L	Empalme en L		
22	✓		GU4870	Kit guarnizione cilindro D.70	Cylinder gasket kit D.70	Zylinderdichtungenset D.70	Kit joint cylindre D.70	Kit junta cilindro D.70		
23	✓		730094580	Sincronizzatore	Synchronizer	Synchronisierer	Synchronisation	Sincronizador		
24	✓		730019310	Boccola motrice	Driving bushing	Antriebsbüchse	Douille motrice	Casquillo motor		
25	✓		730019190	Boccola condotta	Driven bushing	Geführte Büchse	Douille menée	Casquillo conducido		
26	✓		730019290	Distanziale	Spacer	Abstandsstück	Entretoise	Distanciator		
27	✓		730023620	Rondella di bloccaggio	Locking washer	Sperrscheibe	Rondelle de blocage	Arandela de bloqueo		
28	✓		317038	Tubo Elastolan nero 8x5,5 L=2100	8x5.5 black Elastolan hose L=2100	Elastolan Rohr 8x5,5 schwarz L=2100	Tuyau Elastolan 8x5,5 noir L=2100	Tubo Elastolan 8x5,5 negro L=2100		
29	✓		140880060	Protezioni cerchi in lega	Standard clamp protections for alloy rims	Schutzgehäuse für Leichtmetallfelgen	Protection pour jantes en alliage	Protección para llantas de aleación		

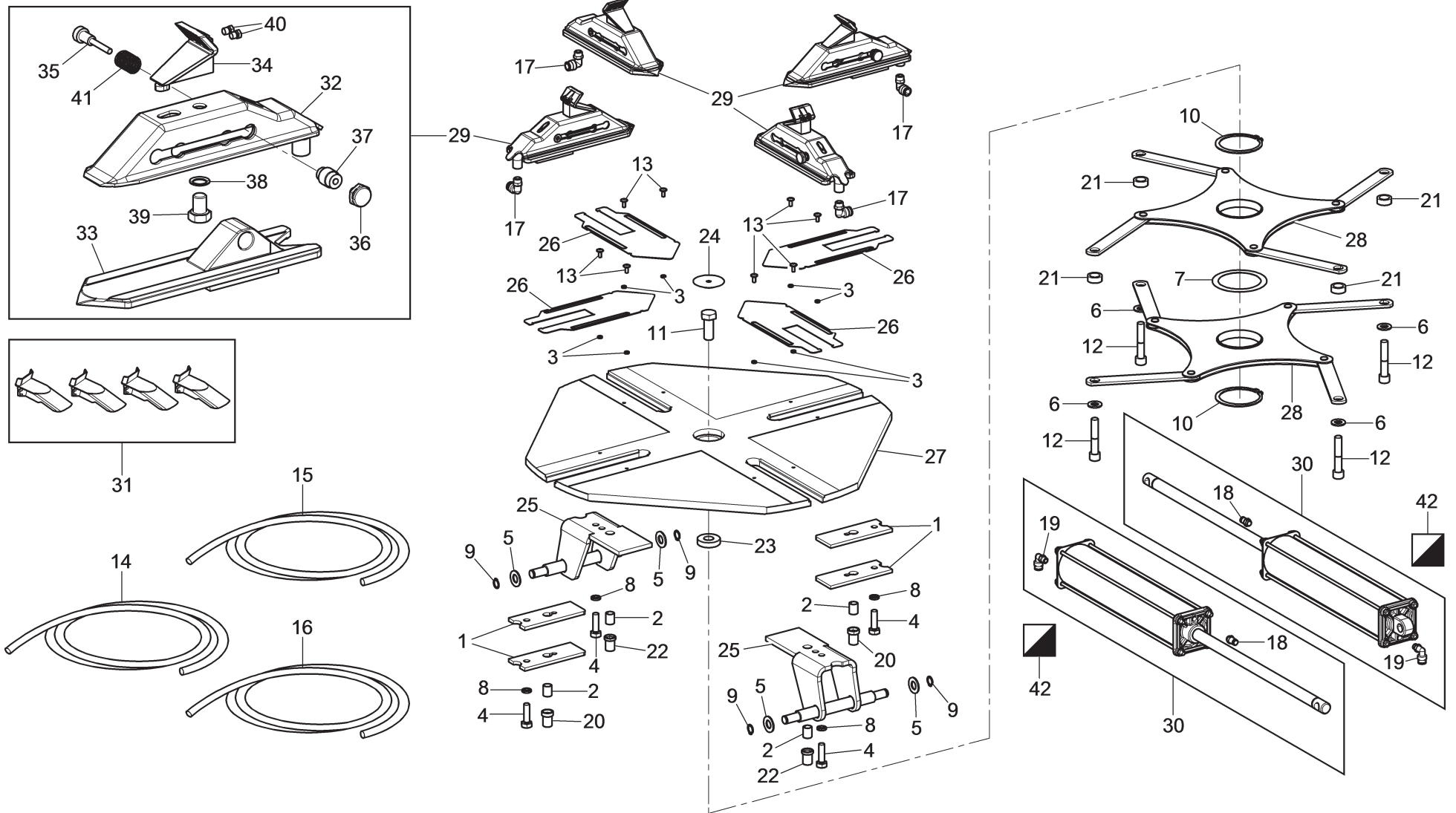

ROT. HP441.201102	ROT. HP641.200888	ROT. HP641.201034	ROT. HP641.200891	ROT. HP641.200785	ROT. HP641.201063	ROT. HP641.201788	ROT. HP641.201072	ROT. HP641.201065	ROT. HP641.201897	ROT. HP643.200894	ROT. HP643.201881	ROT. HP643.201133	ROT. HP643.200983	RAV. G7441.201140	RAV. G7441.200969	RAV. G7441.201119	RAV. G7441.200716	RAV. G7441.200877	RAV. G7441.200821	RAV. G7641.200945	RAV. G7641.200006	RAV. G7641.201041	RAV. G7641.200907	RAV. G7641.200683	RAV. G7641.201010	RAV. G7641.201089	RAV. G7641.200761	RAV. G7645.201232	RAV. G7645.200914	RAV. G7645.200990	RAV. G8645.201249	SPA. GA441.200976	SPA. GA441.201126	SPA. GA441.202000	SPA. GA641.201027	SPA. GA641.201096	SPA. GA641.200952	SPA. GA641.201058	SPA. GA645.200600								
												●																																			
			<b>LISTA DEI COMPONENTI - LIST OF COMPONENTS - TEILELISTE</b> <b>LISTE DES PIÈCES DÉTACHÉES - LISTA DE PIEZAS</b>																		MONTAGGIO MANDRINO 10"-26" 10"-26" CHUCK ASSEMBLY MONTAGE DER SPINDEL 10"-26" MONTAJE MANDRIN 10"-26" MONTAJE MANDRIN 10"-26"																										
			<b>Tavola N°14F - Rev. 0</b>												<b>730094801</b>						<b>Pag. 122 di 235</b>																										



LISTA DEI COMPONENTI - LIST OF COMPONENTS - TEILELISTE  
LISTE DES PIÈCES DÉTACHÉES - LISTA DE PIEZAS

MONTAGGIO MANDRINO 10"-26"  
10"-26" CHUCK ASSEMBLY  
MONTAGE DER SPINDEL 10"-26"  
MONTAGE MANDRIN 10"-26"  
MONTAJE MANDRIL 10"-26"

Tavola N°14F - Rev. 0

730094801

ROT. HF641.201102	ROT. HF641.200938	ROT. HF641.201034	ROT. HF641.200891	ROT. HF641.200785	ROT.HF641.201003	ROT.HF641.201788	ROT. HF641.201072	ROT. HF641.201065	ROT. HF641.201997	ROT.HF643.200984	ROT.HF643.201681	ROT. HF643.201133	ROT. HF643.200983	RAV G7441.201140	RAV G7441.200969	RAV G7441.201119	RAV G7441.200716	RAV G7441.200877	RAV G7441.200921	RAV G7641.200945	RAV G7641.200006	RAV G7641.201041	RAV.G7641.200907	RAV.G7641.200889	RAV G7641.201010	RAV G7641.201089	RAV G7641.200761	RAV G7645.201232	RAV G7645.200914	RAV G7645.200990	RAV G8645.201249	SFA GA441.200976	SFA GA441.201126	SFA GA441.202000	SFA GA641.201027	SFA GA641.201096	SFA GA641.200952	SFA GA641.201058	SFA GA645.200600
----------------------	----------------------	----------------------	----------------------	----------------------	------------------	------------------	----------------------	----------------------	----------------------	------------------	------------------	----------------------	----------------------	---------------------	---------------------	---------------------	---------------------	---------------------	---------------------	---------------------	---------------------	---------------------	------------------	------------------	---------------------	---------------------	---------------------	---------------------	---------------------	---------------------	---------------------	---------------------	---------------------	---------------------	---------------------	---------------------	---------------------	---------------------	---------------------

#		D.R	N	Descrizione	Description	Beschreibung	Description	Descripción		
---	--	-----	---	-------------	-------------	--------------	-------------	-------------	--	--



1	✓		140815322	Piatto per guida slitta	Plate for slide guide	Schlitzenführungsplatte	Plateau pour guide glissière	Placa para guía deslizadora		
2	✓		140816230	Tubino	Small hose	Kleines Rohr	Tuyau petit	Tubo pequeño		
3	✓		140816840	Distanziale	Spacer	Abstandsstück	Entretoise	Distanciadador		
4	✓		203106	TE M10x35	TE M10x35 bolt	Schraube TE M10x35	Vis TE M10x35	Tornillo TE M10x35		
5	✓		236008	Rondella D.15	D.15 washer	Unterlagsscheibe D. 15	Rondelle D.15	Arandela D. 15		
6	✓		236011	Rondella piana 13	13 flat washer	Ebene Unterlagsscheibe 13	Rondelle plane 13	Arandela plana 13		
7	✓		237547	Rondella 75x95x1	75x95x1 washer	Unterlagsscheibe 75x95x1	Rondelle 75x95x1	Arandela 75x95x1		
8	✓		238007	Rondella elastica 10,5	10.5 spring washer	Elastische Unterlagsscheibe 10,5	Rondelle elastique 10,5	Arandela elástica 10,5		
9	✓		243006	Seeger est.14 7435	External clip ring 14 7435	Externer Seeger 14 7435	Anneau de retenue extérieur 14 7435	Seeger externo 14 7435		
10	✓		243026	Seeger Ø 75	Clip ring Ø 75	Seeger Ø 75	Anneau de retenue Ø 75	Seeger Ø 75		
11	✓		256256	TE M16x40	TE M16x40 bolt	Schraube TE M16x40	Vis TE M16x40	Tornillo TE M16x40		
12	✓		258258	TCEI M12x65	TCEI M12x65 bolt	Schraube TCEI M12x65	Vis TCEI M12x65	Tornillo TCEI M12x65		
13	✓		271950	Vite	Bolt	Schraube	Vis	Tornillo		
14	✓		317010	Tubo rilsan 10x8 nero L=1400	10x8 black rilsan hose L=1400	Rilsan Rohr 10x8 schwarz L=1400	Tuyau rilsan 10x8 noir L=1400	Tubo rilsan 10x8 negro L=1400		
15	✓		317021	Tubo Elastolan 10x8 nero L=1900	10x8 black Elastolan hose L=1900	Elastolan Rohr 10x8 schwarz L=1900	Tuyau Elastolan 10x8 noir L=1900	Tubo Elastolan 10x8 negro L=1900		
16	✓		317038	Tubo Elastolan nero 8x5,5 L=2100	8x5.5 black Elastolan hose L=2100	Elastolan Rohr 8x5,5 schwarz L=2100	Tuyau Elastolan 8x5,5 noir L=2100	Tubo Elastolan 8x5,5 negro L=2100		
17	✓		325107	Raccordo	Fitting	Anschluss	Raccord	Empalme		
18	✓		325110	Raccordo	Fitting	Anschluss	Raccord	Empalme		
19	✓		325159	Raccordo a L	L-shaped fitting	L-Anschluss	Raccord à L	Empalme en L		
20	✓		730019190	Boccola condotta	Driven bushing	Geführte Büchse	Douille menée	Casquillo conducido		
21	✓		730019290	Distanziale	Spacer	Abstandsstück	Entretoise	Distanciadador		
22	✓		730019310	Boccola motrice	Driving bushing	Antriebsbüchse	Douille motrice	Casquillo motor		
23	✓		730023620	Rondella di bloccaggio	Locking washer	Sperrscheibe	Rondelle de blocage	Arandela de bloqueo		
24	✓		730023630	Tappo	Plug	Stöpsel	Bouchon	Tapón		
25	✓		730024600	Insieme cavallotto	U bolt assembly	U-förmige Bügelbolzensatz	Ensemble bride en forme de U	Conjunto brida en forma de "u"		
26	✓		730028940	Salvadita 10"-26"	10"-26" finger protection device	Handschutzeinrichtung 10"-26"	Dispositif protection doigts 10"-26"	Dispositivo protección ditos 10"-26"		
27	✓		730024690	Insieme mandrino 10-26	10"-26" chuck assembly	Spindelsatz 10"-26"	Ensemble mandrin 10"-26"	Conjunto mandril 10"-26"		
28	✓		730094580	Sincronizzatore	Synchronizer	Synchronisierer	Synchronisation	Sincronizador		
29	✓		730095650	Insieme slitta	Slide assembly	Schlittensatz	Ensemble coulisseau	Conjunto deslizadora		
30	✓		730096900	Montaggio cilindro pneumatico	Pneumatic cylinder assembly	Pneumatikzylindermontage	Montage cylindre pneumatique	Montaje cilindro neumático		

ROT. HP641.201102	ROT. HP641.200938	ROT. HP641.201034	ROT. HP641.200891	ROT. HP641.200785	ROT. HP641.201003	ROT. HP641.201788	ROT. HP641.201072	ROT. HP641.201065	ROT. HP641.201997	ROT. HP643.200984	ROT. HP643.201681	ROT. HP643.201133	ROT. HP643.200983	RAV. G7441.201140	RAV. G7441.200969	RAV. G7441.201119	RAV. G7441.200716	RAV. G7441.200877	RAV. G7441.200921	RAV. G7641.200945	RAV. G7641.200006	RAV. G7641.201041	RAV. G7641.200907	RAV. G7641.200989	RAV. G7641.201010	RAV. G7641.201089	RAV. G7641.200761	RAV. G7645.201232	RAV. G7645.200914	RAV. G7645.200990	RAV. G8645.201249	SFA. GA441.200976	SFA. GA441.201126	SFA. GA441.202000	SFA. GAG41.201027	SFA. GAG41.201096	SFA. GAG41.200952	SFA. GAG41.201058	SFA. GAG45.200600					
												●																																
<b>#</b>		<b>D.R</b>	<b>N</b>	<b>Descrizione</b>	<b>Description</b>	<b>Beschreibung</b>	<b>Description</b>	<b>Descripción</b>																																				

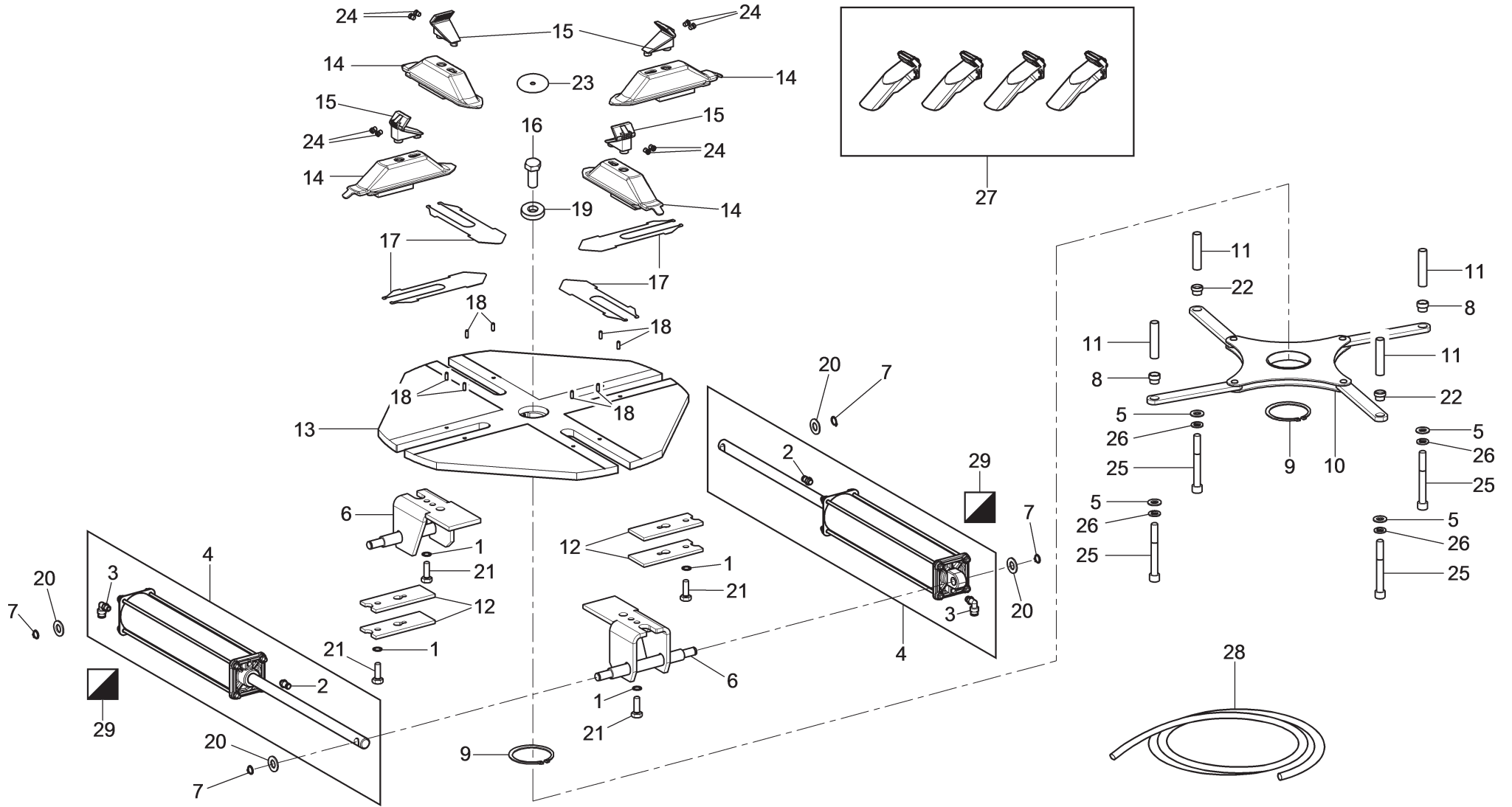
31	✓		140880060	Protezioni cerchi in lega	Standard clamp protections for alloy rims	Schutzgehäuse für Leichtmetallfelgen	Protection pour jantes en alliage	Protección para llantas de aleación																																				
32	✓		730026250	Slitta saldata	Welded slide	Geschweißter Schlitten	Coulisseau soudé	Deslizadora soldada																																				
33	✓		730028490	Piastra	Plate	Platte	Plaque	Placa																																				
34	✓		140816221	Griffa	Jaw	Backe	Griffe	Garra																																				
35	✓		730023531	Riposizionatore	Repositioner	Wiederstellungsregler	Repositionneur	Reposicionador																																				
36	✓		730021330	Pulsante	Push-button	Knopf	Poussoir	Pulsador																																				
37	✓		730021341	Perno riposizionatore	Repositioner pin	Wiederstellungsreglerzapfen	Pivot repositionneur	Perno reposicionador																																				
38	✓		299081	Rondella	Washer	Unterlagsscheibe	Rondelle	Arandela																																				
39	✓		256069	TE M12x16	TE M12x16 bolt	Schraube TE M12x16	Vis TE M12x16	Tornillo TE M12x16																																				
40	✓		730023440	Punta x griffa	Point for jaw	Spitze für Backe	Pointe pour griffe	Punta para garra																																				
41	✓		918037	Molla a compressione 1.5X15.5X20x5	Compression spring 1.5X15.5X20x5	Druckfeder 1.5X15.5X20x5	Ressort de compression 1.5X15.5X20x5	Resorte de compresión 1.5X15.5X20x5																																				
42	✓		GU4870	Kit guarnizione cilindro D.70	Cylinder gasket kit D.70	Zylinderdichtungenset D.70	Kit joint cylindre D.70	Kit junta cilindro D.70																																				



ROT. HP441.201102	ROT. HP641.200838	ROT. HP641.201034	ROT. HP641.200891	ROT. HP641.200785	ROT. HP641.201003	ROT. HP641.201788	ROT. HP641.201072	ROT. HP641.201065	ROT. HP641.201897	ROT. HP643.200894	ROT. HP643.201881	ROT. HP643.201133	ROT. HP643.200983	RAV. G7441.201140	RAV. G7441.200969	RAV. G7441.201119	RAV. G7441.200716	RAV. G7441.200877	RAV. G7441.200821	RAV. G7641.200945	RAV. G7641.200006	RAV. G7641.201041	RAV. G7641.200907	RAV. G7641.200683	RAV. G7641.201010	RAV. G7641.201089	RAV. G7641.200761	RAV. G7645.201232	RAV. G7645.200914	RAV. G7645.200990	RAV. G8645.201249	SFA. GA441.200976	SFA. GA441.201126	SFA. GA441.202000	SFA. GA641.201027	SFA. GA641.201096	SFA. GA641.200952	SFA. GA641.201058	SFA. GA645.200600
																										<b>LISTA DEI COMPONENTI - LIST OF COMPONENTS - TEILELISTE</b> <b>LISTE DES PIÈCES DÉTACHÉES - LISTA DE PIEZAS</b>				MONTAGGIO MANDRINO QUADRO 10"-20" 10"-20" SQUARE CHUCK ASSEMBLY MONTAGE DER QUADRATISCHEN SPINDEL 10"-20" MONTAGE MANDRIN CARRÉ 10"-20" MONTAJE MANDRIL CUADRADO 10"-20"									
																										Tavola N°14G - Rev. 0													730093190

		<b>LISTA DEI COMPONENTI - LIST OF COMPONENTS - TEILELISTE</b> <b>LISTE DES PIÈCES DÉTACHÉES - LISTA DE PIEZAS</b>										MONTAGGIO MANDRINO QUADRO 10"-20" 10"-20" SQUARE CHUCK ASSEMBLY MONTAGE DER QUADRATISCHEN SPINDEL 10"-20" MONTAGE MANDRIN CARRÉ 10"-20" MONTAJE MANDRIL CUADRADO 10"-20"										<b>Pag. 126 di 235</b> 																			
		<b>Tavola N°14G - Rev. 0</b>					<b>730093190</b>																																		
ROT. HF641.201102	ROT. HF641.200938	ROT. HF641.201034	ROT. HF641.200891	ROT. HF641.200785	ROT. HF641.201003	ROT. HF641.201788	ROT. HF641.201072	ROT. HF641.201065	ROT. HF641.201997	ROT. HF643.200984	ROT. HF643.201681	ROT. HF643.201133	ROT. HF643.200983	RAV. G7441.201140	RAV. G7441.200969	RAV. G7441.201119	RAV. G7441.200716	RAV. G7441.200877	RAV. G7441.200921	RAV. G7641.200945	RAV. G7641.200006	RAV. G7641.201041	RAV. G7641.200907	RAV. G7641.200689	RAV. G7641.201010	RAV. G7641.201089	RAV. G7641.200761	RAV. G7645.201232	RAV. G7645.200914	RAV. G7645.200990	RAV. G8645.201249	SFA. GA441.200976	SFA. GA441.201126	SFA. GA441.202000	SFA. GA641.201027	SFA. GA641.201096	SFA. GA641.200952	SFA. GA641.201058	SFA. GA645.200600		
#		D.R	N	Descrizione	Description	Beschreibung	Description	Descripción																																	

1	✓		239020	Rondella dentata 10,5	10.5 toothed washer	Zahnunterlagscheibe 10,5	Rondelle dentée 10,5	Arandela dentada 10,5		
2	✓		325110	Raccordo	Fitting	Anschluss	Raccord	Empalme		
3	✓		325159	Raccordo a L	L-shaped fitting	L-Anschluss	Raccord à L	Empalme en L		
4	✓		140890023	Cilindro 10" - 20"	10" - 20" cylinder	Zylinder 10" - 20"	Cylindre 10" - 20"	Cilindro 10" - 20"		
5	✓		236011	Rondella piana 13	13 flat washer	Ebene Unterlagsscheibe 13	Rondelle plane 13	Arandela plana 13		
6	✓		140841602	Insieme cavallotto	U bolt assembly	U-förmige Bügelbolzensatz	Ensemble bride en forme de U	Conjunto brida en forma de "u"		
7	✓		243006	Seeger est.14 7435	External clip ring 14 7435	Externer Seeger 14 7435	Anneau de retenue extérieur 14 7435	Seeger esterno 14 7435		
8	✓		730027740	Boccola condotta	Driven bushing	Geführte Büchse	Douille menée	Casquillo conducido		
9	✓		243026	Seeger Ø 75	Clip ring Ø 75	Seeger Ø 75	Anneau de retenue Ø 75	Seeger Ø 75		
10	✓		140815413	Sincronizzatore 18-20	18-20 synchronizer	Synchronisierer 18-20	Synchronisation 18-20	Sincronizador 18-20		
11	✓		730017970	Tubino	Small hose	Kleines Rohr	Tuyau petit	Tubo pequeño		
12	✓		140815322	Piatto per guida slitta	Plate for slide guide	Schlitzenführungsplatte	Plateau pour guide glissière	Placa para guía deslizadera		
13	✓		140925015	Insieme mandrino quadro 10"-20"	10"-20" square chuck assembly	Quadratischer Spindelsatz 10"-20"	Ensemble mandrin carré 10"-20"	Conjunto mandril cuadrado 10"-20"		
14	✓		730019880	Supporto griffa	Jaw support	Backenträger	Support griffe	Soporte garra		
15	✓		140815044	Griffa	Jaw	Backe	Griffe	Garra		
16	✓		256256	TE M16x40	TE M16x40 bolt	Schraube TE M16x40	Vis TE M16x40	Tornillo TE M16x40		
17	✓		140815403	Salvadita	Finger protection device	Handschutzeinrichtung	Dispositif protection doigts	Dispositivo protección ditos		
18	✓		235052	Spina elastica	Elastic pin	Elastischer Zapfen	Goupille élastique	Clavija elástica		
19	✓		730023620	Rondella di bloccaggio	Locking washer	Sperrscheibe	Rondelle de blocage	Arandela de bloqueo		
20	✓		236008	Rondella D.15	D.15 washer	Unterlagsscheibe D. 15	Rondelle D.15	Arandela D. 15		
21	✓		203193	TE M10x30	TE M10x30 bolt	Schraube TE M10x30	Vis TE M10x30	Tornillo TE M10x30		
22	✓		730027730	Boccola motrice	Driving bushing	Antriebsbüchse	Douille motrice	Casquillo motor		
23	✓		730023630	Tappo	Plug	Stöpsel	Bouchon	Tapón		
24	✓		730023440	Punta x griffa	Point for jaw	Spitze für Backe	Pointe pour griffe	Punta para garra		
25	✓		258216	TCEI M12x100	TCEI M12x100 bolt	Schraube TCEI M12x100	Vis TCEI M12x100	Tornillo TCEI M12x100		
26	✓		238011	Rondella elastica 13	13 spring washer	Elastische Unterlagsscheibe 13	Rondelle elastique 13	Arandela elástica 13		
27	✓		770090190	Protezioni cerchi in lega	Standard clamp protections for alloy rims	Schutzgehäuse für Leichtmetallfelgen	Protection pour jantes en alliage	Protección para llantas de aleación		
28	✓		317038	Tubo Elastolan nero 8x5,5 L=2200	8x5.5 black Elastolan hose L=2200	Elastolan Rohr 8x5,5 schwarz L=2200	Tuyau Elastolan 8x5,5 noir L=2200	Tubo Elastolan 8x5,5 negro L=2200		
29	✓		GU4870	Kit guarnizione cilindro D.70	Cylinder gasket kit D.70	Zylinderdichtungenset D.70	Kit joint cylindre D.70	Kit junta cilindro D.70		

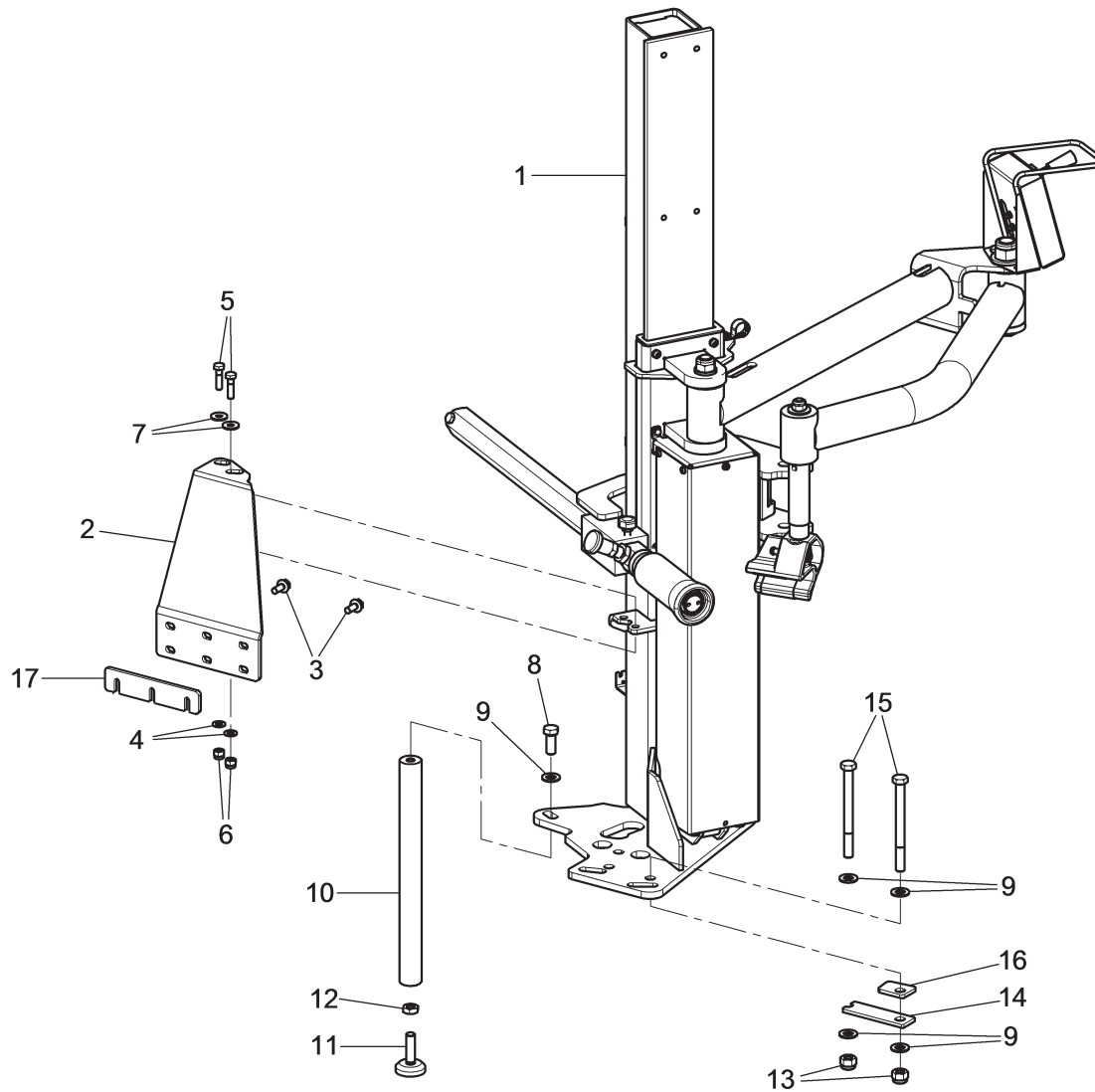

ROT. HP441.201102	ROT. HP641.200838	ROT. HF641.201034	ROT. HP641.200891	ROT. HF641.200785	ROT.HP641.201063	ROT.HP641.201788	ROT. HF641.201072	ROT. HF641.201065	ROT. HF641.201897	ROT.HF643.200884	ROT.HF643.201881	ROT. HF643.201133	ROT. HF643.200983	RAV. G7441.201140	RAV. G7441.200969	RAV. G7441.201119	RAV. G7441.200716	RAV. G7441.200877	RAV. G7441.200821	RAV. G7641.200945	RAV. G7641.200006	RAV. G7641.201010	RAV. G7641.201089	RAV. G7641.200761	RAV. G7645.201232	RAV. G7645.200914	RAV. G7645.200990	RAV. G8645.201249	SFA. GA441.200976	SPA. GA441.201126	SFA. GA441.202000	SFA. GA641.201027	SFA. GA641.201096	SFA. GA641.200952	SFA. GA641.201058	SFA. GA645.200600						
			•	•				•		•	•	•																														
		<b>LISTA DEI COMPONENTI - LIST OF COMPONENTS - TEILELISTE</b> <b>LISTE DES PIÈCES DÉTACHÉES - LISTA DE PIEZAS</b>																			PREMITALLONE PNEUMATICO PNEUMATIC BEAD PRESS PNEUMATISCHER WULSTABDRÜCKER POUSSE-TALON PNEUMATIQUE PRESIONATALÓN NEUMÁTICO																					
		Tavola N°15A - Rev. 0					770790970											<b>Pag. 127 di 235</b>																								



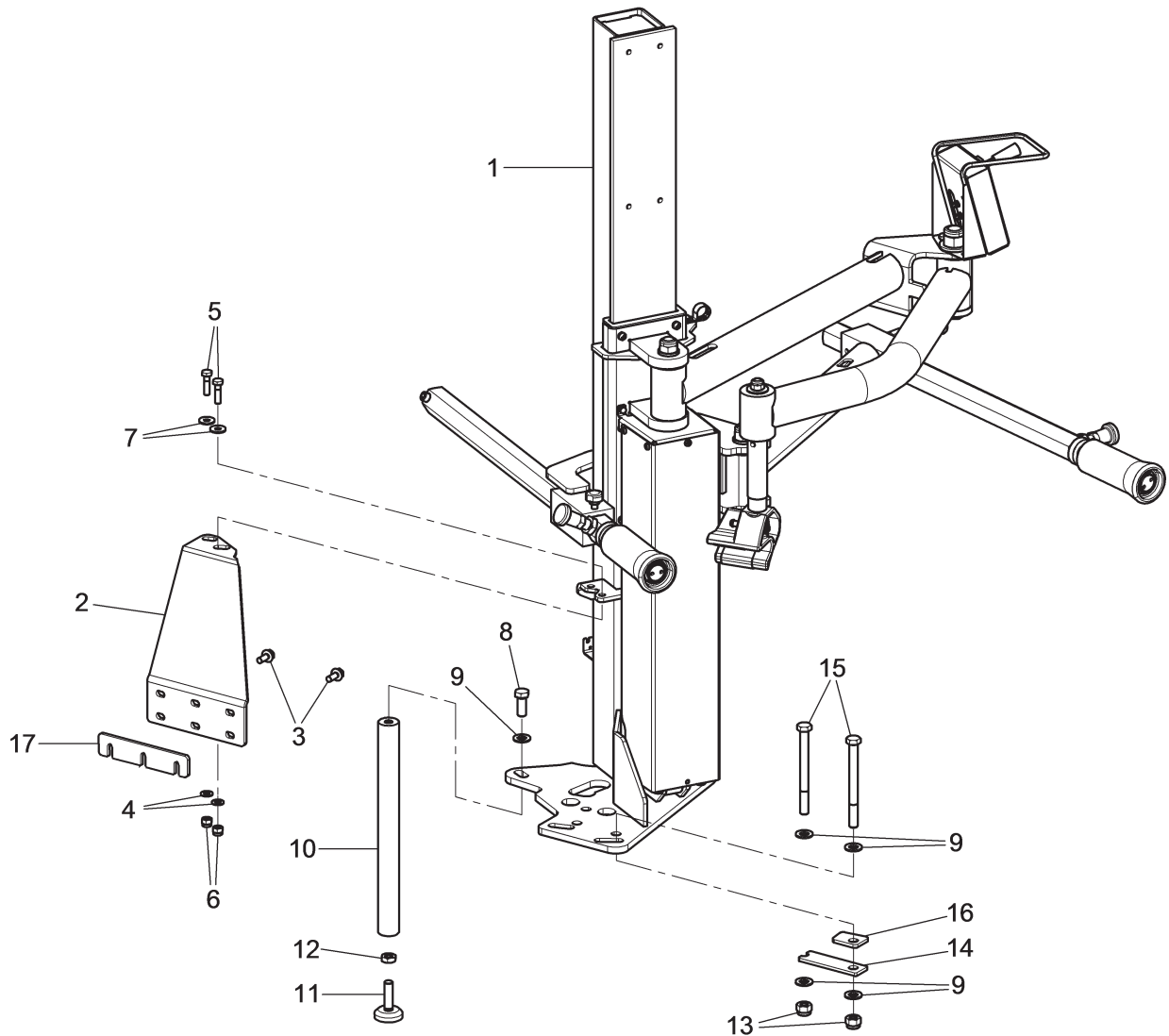

ROT. HP441.201102	ROT. HP641.200838	ROT. HF641.201034	ROT. HP641.200891	ROT. HF641.200785	ROT.HF641.201003 ROT.HF641.201788	ROT. HP641.201072	ROT. HF641.201065	ROT. HF641.201897	ROT.HF643.200894 ROT.HF643.201881	ROT. HF643.201133	ROT. HF643.200983	RAV. G7441.201140	RAV. G7441.200969	RAV. G7441.201119	RAV. G7441.200716	RAV. G7441.200877	RAV. G7441.200821	RAV. G7641.200945	RAV. G7641.200006	RAV. G7641.201041	RAV.G7641.200907 RAV.G7641.200683	RAV. G7641.201010	RAV. G7641.201089	RAV. G7641.200761	RAV. G7645.201232	RAV. G7645.200914	RAV. G7645.200990	RAV. G8645.201249	SFA. GA441.200976	SPA. GA441.201126	SFA. GA441.202000	SFA. GA641.201027	SFA. GA641.201096	SFA. GA641.200952	SFA. GA641.201058	SFA. GA645.200600													
																	•				•																												



**LISTA DEI COMPONENTI - LIST OF COMPONENTS - TEILELISTE  
LISTE DES PIECES DETACHEES - LISTA DE PIEZAS**

**Tavola N°15B - Rev. 0**                      **770791000**

PREMITALLONE PNEUMATICO  
PNEUMATIC BEAD PRESS  
PNEUMATISCHER WULSTABDRÜCKER  
POUSSE-TALON PNEUMATIQUE  
PRESIONATALÓN NEUMÁTICO



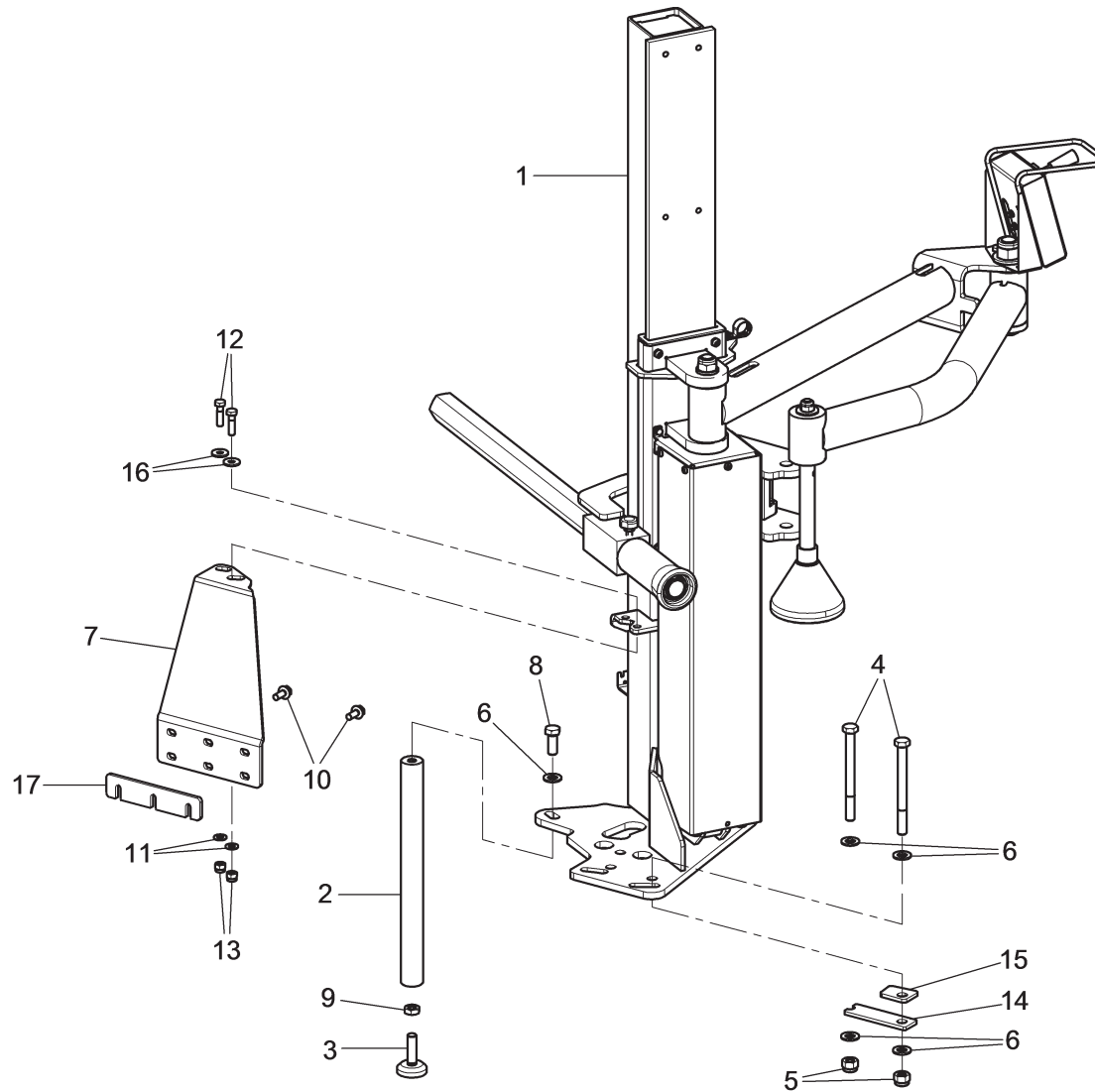

ROT. HP441.201102	ROT. HP641.200838	ROT. HF641.201034	ROT. HP641.200891	ROT. HF641.200785	ROT.HF641.201063 ROT.HF641.201788	ROT. HF641.201072	ROT. HF641.201065	ROT. HF641.201897	ROT.HF643.200894 ROT.HF643.201881	ROT. HF643.201133	ROT. HF643.200983	RAV. G7441.201140	RAV. G7441.200969	RAV. G7441.201119	RAV. G7441.200716	RAV. G7441.200877	RAV. G7441.200821	RAV. G7641.200945	RAV. G7641.200006	RAV. G7641.201010	RAV. G7641.201089	RAV. G7641.200761	RAV. G7645.201232	RAV. G7645.200914	RAV. G7645.200990	RAV. G8645.201249	SFA. GA441.200976	SPA. GA441.201126	SFA. GA441.202000	SPA. GA641.201027	SFA. GA641.201096	SPA. GA641.200952	SPA. GA641.201058	SPA. GA645.200600
----------------------	----------------------	----------------------	----------------------	----------------------	--------------------------------------	----------------------	----------------------	----------------------	--------------------------------------	----------------------	----------------------	----------------------	----------------------	----------------------	----------------------	----------------------	----------------------	----------------------	----------------------	----------------------	----------------------	----------------------	----------------------	----------------------	----------------------	----------------------	----------------------	----------------------	----------------------	----------------------	----------------------	----------------------	----------------------	----------------------



**LISTA DEI COMPONENTI - LIST OF COMPONENTS - TEILELISTE  
LISTE DES PIÈCES DÉTACHÉES - LISTA DE PIEZAS**

**Tavola N°15C - Rev. 0**

**770791020**

PREMITALLONE PNEUMATICO  
PNEUMATIC BEAD PRESS  
PNEUMATISCHER WULSTABDRÜCKER  
POUSSE-TALON PNEUMATIQUE  
PRESIONATALÓN NEUMÁTICO

**Pag. 131 di 235**



LISTA DEI COMPONENTI - LIST OF COMPONENTS - TEILELISTE  
LISTE DES PIÈCES DÉTACHÉES - LISTA DE PIEZAS

PREMITALLONE PNEUMATICO  
PNEUMATIC BEAD PRESS  
PNEUMATISCHER WULSTABDRÜCKER  
POUSSE-TALON PNEUMATIQUE  
PRESIONATALÓN NEUMÁTICO

Pag. 132 di 235

Tavola N°15C - Rev. 0

770791020

#		D.R	N	Descrizione	Description	Beschreibung	Description	Descripción		
---	--	-----	---	-------------	-------------	--------------	-------------	-------------	--	--

1	✓	16C.0	770791010	Premitallone	Bead press	Wulstabdrücker	Pousse-talon	Presionatalón		
2	✓		770713460	Piede posteriore	Rear foot	Hinterfuß	Pied postérieur	Pie posterior		
3	✓		B0013000	Piede in gomma	Rubber foot	Gummifuß	Pied en caoutchouc	Pie en goma		
4	✓		201382	TE M12x130	TE M12x130 bolt	Schraube TE M12x130	Vis TE M12x130	Tornillo TE M12x130		
5	✓		228006	Dado autobloccante M12	M12 self-locking nut	Selbstsichernde Mutter M12	Écrou auto-bloquant M12	Tuerca autobloccante M12		
6	✓		236011	Rondella piana 13	13 flat washer	Ebene Unterlagsscheibe 13	Rondelle plane 13	Arandela plana 13		
7	✓		770713201	Staffa laterale	Lateral bracket	Seitenbügel	Bride latérale	Brida lateral		
8	✓		203072	TE M12x30	TE M12x30 bolt	Schraube TE M12x30	Vis TE M12x30	Tornillo TE M12x30		
9	✓		226015	Dado esagonale basso M12	M12 jam hex nut	Niedrige Sechskantmutter M12	Écrou hexagonal bas M12	Tuerca hexagonal baja M12		
10	✓		272035	TE M8x20	TE M8x20 bolt	Schraube TE M8x20	Vis TE M8x20	Tornillo TE M8x20		
11	✓		236006	Rondella piana 8,4	8.4 flat washer	Ebene Unterlagsscheibe 8,4	Rondelle plane 8,4	Arandela plana 8,4		
12	✓		201040	TE M8x30	TE M8x30 bolt	Schraube TE M8x30	Vis TE M8x30	Tornillo TE M8x30		
13	✓		228011	Dado autobloccante M8	M8 self-locking nut	Selbstsichernde Mutter M8	Écrou auto-bloquant M8	Tuerca autobloccante M8		
14	✓		770711800	Distanziale	Spacer	Abstandsstück	Entretoise	Distanciador		
15	✓		770711250	Distanziale telaio	Frame spacer	Rahmenabstandsstück	Entretoise châssis	Distanciador bastidor		
16	✓		237072	Rosetta D.8,4x22x2,5	D.8.4x22x2.5 washer	Unterlegscheibe D.8,4x22x2,5	Rondelle D.8,4x22x2,5	Arandela D.8,4x22x2,5		
17	✓		770714181	Distanziale	Spacer	Abstandsstück	Entretoise	Distanciador		

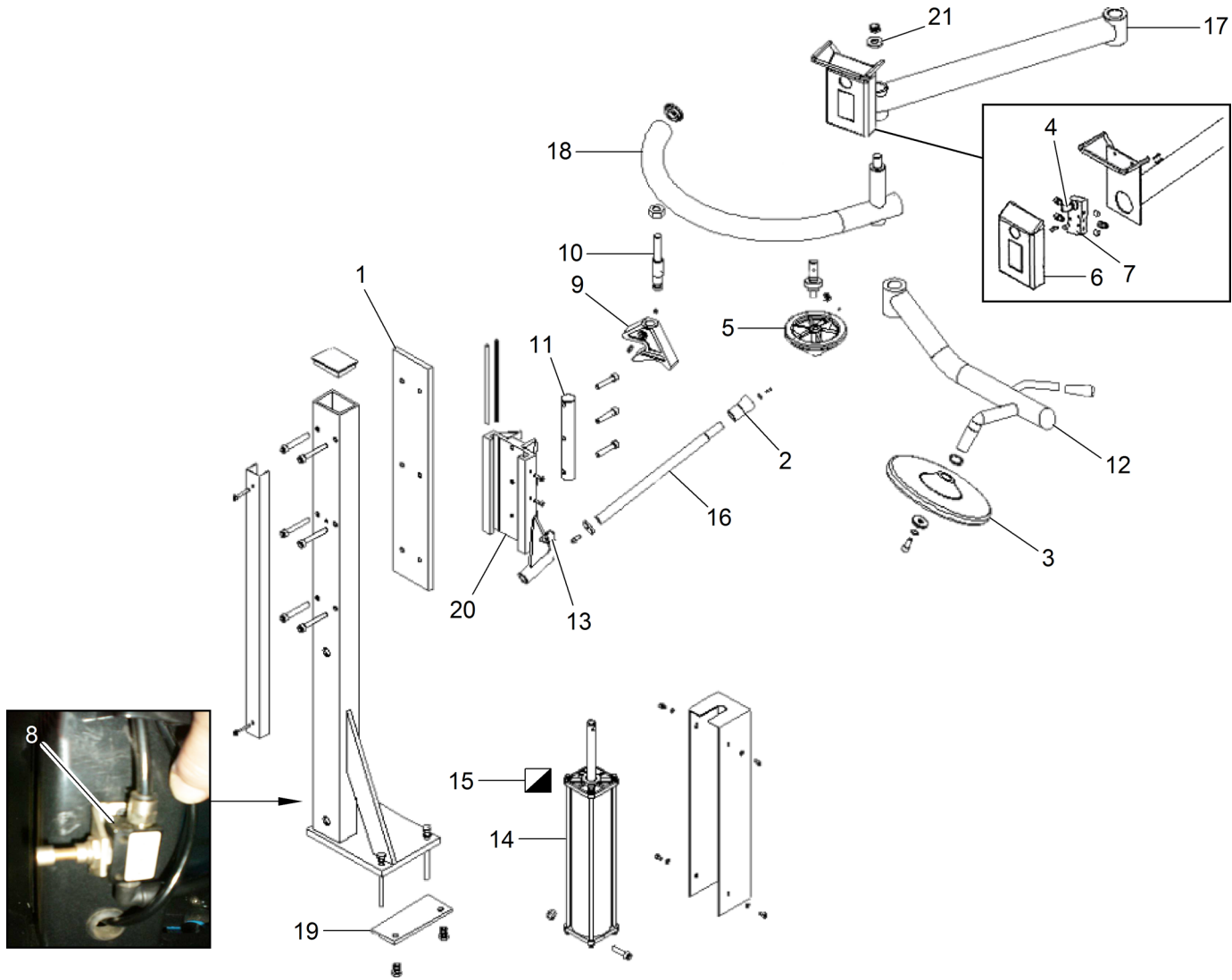

ROT. HP441.201102	ROT. HP641.200838	ROT. HF641.201034	ROT. HP641.200891	ROT. HF641.200785	ROT.HP641.201003	ROT.HP641.201788	ROT. HF641.201072	ROT. HF641.201065	ROT. HP641.201897	ROT.HP643.200894	ROT.HP643.201881	ROT. HP643.201133	ROT. HF643.200983	RAV. G7441.201140	RAV. G7441.200969	RAV. G7441.201119	RAV. G7441.200716	RAV. G7441.200877	RAV. G7441.200821	RAV. G7641.200945	RAV. G7641.200006	RAV. G7641.201041	RAV.G7641.200907	RAV.G7641.200683	RAV. G7641.201010	RAV. G7641.201089	RAV. G7641.200761	RAV. G7645.201232	RAV. G7645.200914	RAV. G7645.200990	RAV. G8645.201249	SFA. GA441.200976	SPA. GA441.201126	SFA. GA441.202000	SPA. GA641.201027	SPA. GA641.201096	SPA. GA641.200952	SPA. GA641.201058	SPA. GA645.200600
----------------------	----------------------	----------------------	----------------------	----------------------	------------------	------------------	----------------------	----------------------	----------------------	------------------	------------------	----------------------	----------------------	----------------------	----------------------	----------------------	----------------------	----------------------	----------------------	----------------------	----------------------	----------------------	------------------	------------------	----------------------	----------------------	----------------------	----------------------	----------------------	----------------------	----------------------	----------------------	----------------------	----------------------	----------------------	----------------------	----------------------	----------------------	----------------------



**LISTA DEI COMPONENTI - LIST OF COMPONENTS - TEILELISTE  
LISTE DES PIÈCES DÉTACHÉES - LISTA DE PIEZAS**

**Tavola N°15D - Rev. 0**

**PLUS73**

DISPOSITIVO PREMI-ALZA TALLONE PNEUMATICO  
PNEUMATIC BEAD PRESS/LIFT DEVICE  
PNEUMATISCHE WULSTABDRÜCK-HUBVORRICHTUNG  
DISPOSITIF POUSSE-LÈVE PNEU  
DISPOSITIVO PRESIONA-LEVANTATALÓN NEUMÁTICO



LISTA DEI COMPONENTI - LIST OF COMPONENTS - TEILELISTE  
LISTE DES PIÈCES DÉTACHÉES - LISTA DE PIEZAS

DISPOSITIVO PREMI-ALZA TALLONE PNEUMATICO  
PNEUMATIC BEAD PRESS/LIFT DEVICE  
PNEUMATISCHE WULSTABDRÜCK-HUBVORRICHTUNG  
DISPOSITIF POUSSE-LEVE PNEU  
DISPOSITIVO PRESIONA-LEVANTATALÓN NEUMÁTICO

Tavola N°15D - Rev. 0

PLUS73

#	D.R	N	Descrizione	Description	Beschreibung	Description	Descripción		
1	✓		770770010	Pattino guida carro	Carrriage guide sliding block	Wagenführungsschlitten	Patin de guide chariot	Patín de guía carro	
2	✓		770770020	Rullo conico	Conic roller	Konische Rolle	Rouleau contique	Rodillo cónico	
3	✓		770770030	Disco D.250	D.250 disc	Scheibe D.250	Disque D.250	Disco D.250	
4	✓		770770040	Levetta comando valvola	Valve control lever	Ventilsteuerhebel	Levier commande soupape	Palanca comando válvula	
5	✓		770770050	Cono di centraggio	Centring cone	Zentrierkegel	Cône de centrage	Cono de centrado	
6	✓		770770060	Carter copertura valvola	Valve covering guard	Ventilsabdeckgehäuse	Carter couverture soupape	Cárter cobertura válvula	
7	✓		770770070	Valvola di comando	Control valve	Steuerventil	Soupape commande	Válvula mando	
8	✓		770770080	Regolatore di flusso	Flow regulator	Flussregler	Regulateur de débit	Regulador de flujo	
9	✓		770770090	Utensile premitallone	Bead press tool	Wulstabdruckwerkzeug	Outil pousse-talon	Útil presionatalón	
10	✓		770770100	Perno	Pin	Zapfen	Pivot	Perno	
11	✓		770713390	Perno supporto bracci	Arms support pin	Armstützapfen	Pivot support bras	Perno soporte brazos	
12	✓		770770200	Braccio porta disco	Disc holder arm	Scheibenträgerarm	Bras porte-disque	Braccio porta disco	
13	✓		903105	Pomolo M10x50	M10x50 knob	Handgriff M10x50	Poignée M10x50	Pomo M10x50	
14	✓		770770110	Cilindro pneumatico	Pneumatic cylinder	Pneumatikzylinder	Cylindre pneumatique	Cilindro neumático	
15	✓		GU6100	Kit guarnizione cilindro	Cylinder gasket kit	Zylinderdichtungenset	Kit joint cylindre	Kit junta cilindro	
16	✓		770770120	Albero supporto rullo	Roller support shaft	Rollenstützwelle	Arbre support rouleau	Eje soporte rodillo	
17	✓		770770140	Braccio unità di comando	Control assembly arm	Antriebsatzarm	Bras unité de commande	Braccio unidad de mando	
18	✓		770770150	Braccio pressore	Pusher arm	Drückerarm	Bras presseur	Braccio prensador	
19	✓		730026510	Lamiera di spessoramento	Shim plate	Beilagsblech	Tôle d'épaisseur	Chapa de espesor	
20	✓		770770160	Supporto scorrevole bracci	Sliding arm support	Verschiebbare Armstütze	Support bras coulissant	Soporte brazos deslizante	
21	✓		770770130	Rondella perno fulcro	Pivot pin washer	Drehpunktzapfenunterlagsscheibe	Pivot point d'appui rondelle	Perno fulcro arandela	

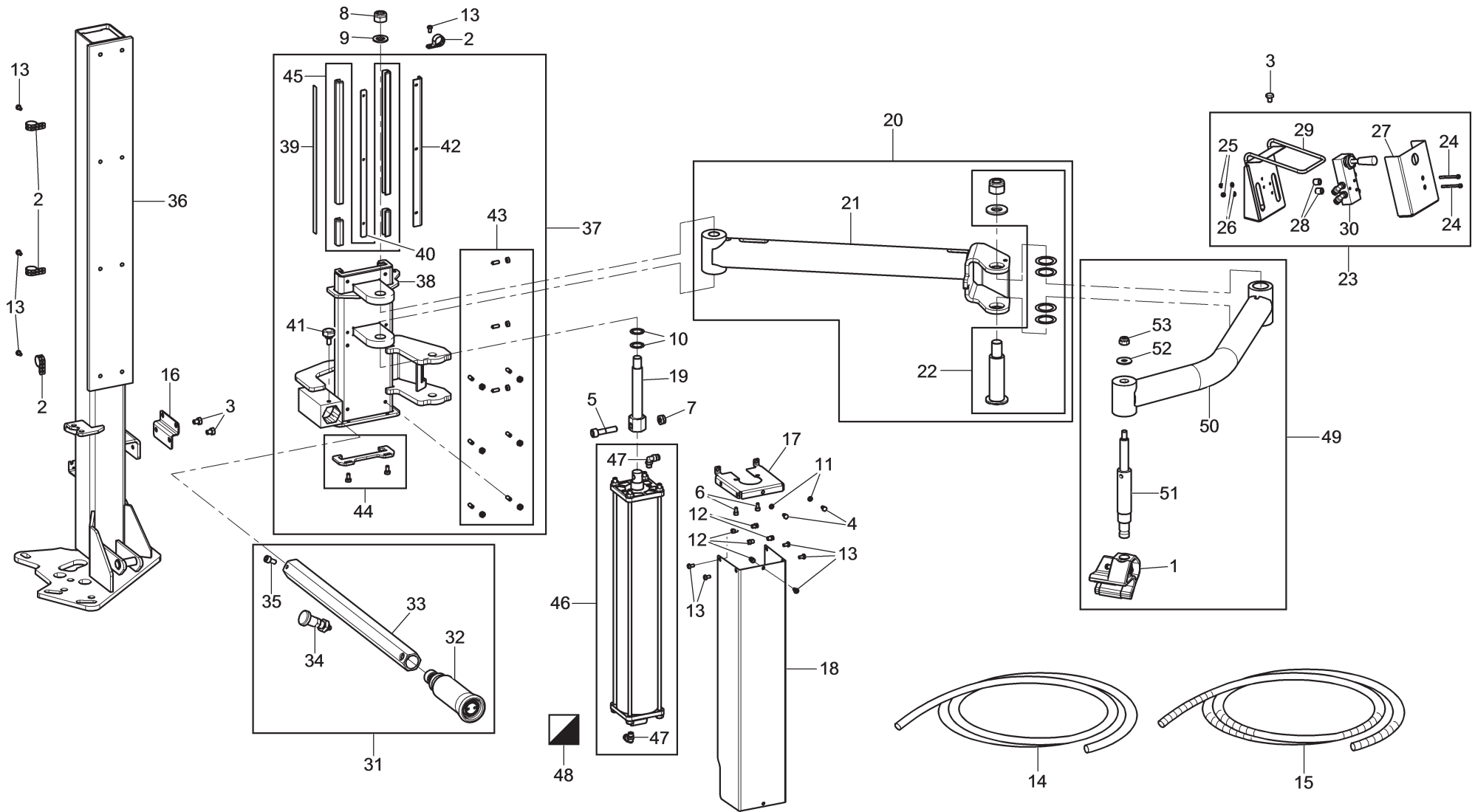

ROT. HP441.201102	ROT. HP641.200988	ROT. HP641.201034	ROT. HP641.200891	ROT. HP641.200785	ROT. HP641.201063	ROT. HP641.201788	ROT. HP641.201072	ROT. HP641.201065	ROT. HP641.201997	ROT. HP643.200894	ROT. HP643.201881	ROT. HP643.201133	ROT. HP643.200983	RAV. G7441.201140	RAV. G7441.200969	RAV. G7441.201119	RAV. G7441.200716	RAV. G7441.200877	RAV. G7441.200821	RAV. G7641.200945	RAV. G7641.200006	RAV. G7641.201041	RAV. G7641.200907	RAV. G7641.200683	RAV. G7641.201010	RAV. G7641.201089	RAV. G7641.200761	RAV. G7645.201232	RAV. G7645.200914	RAV. G7645.200990	RAV. G8645.201249	SPA. GA441.200976	SPA. GA441.201126	SPA. GA441.202000	SPA. GA641.201027	SPA. GA641.201096	SPA. GA641.200952	SPA. GA641.201058	SPA. GA645.200600				
			●	●				●		●	●	●																															







**LISTA DEI COMPONENTI - LIST OF COMPONENTS - TEILELISTE  
LISTE DES PIÈCES DÉTACHÉES - LISTA DE PIEZAS**



**Tavola N°16A - Rev. 0**

**770790980**

PREMITALLONE  
BEAD PRESS  
WULSTABDRÜCKER  
POUSSE-TALON  
PRESIONATALÓN

		<b>LISTA DEI COMPONENTI - LIST OF COMPONENTS - TEILELISTE</b> <b>LISTE DES PIÈCES DÉTACHÉES - LISTA DE PIEZAS</b>												PREMITALLONE BEAD PRESS WULSTABDRÜCKER POUSSE-TALON PRESIONATALÓN				<b>Pag. 136 di 235</b>																								
		<b>Tavola N°16A - Rev. 0</b>						<b>770790980</b>																																		
ROT. HP641.201102	ROT. HP641.200938	ROT. HP641.201034	ROT. HP641.200891	ROT. HP641.200785	ROT. HP641.201003	ROT. HP641.201788	ROT. HP641.201072	ROT. HP641.201065	ROT. HP641.201997	ROT. HP643.200984	ROT. HP643.201681	ROT. HP643.201133	ROT. HP643.200983	RAV. G7441.201140	RAV. G7441.200969	RAV. G7441.201119	RAV. G7441.200716	RAV. G7441.200877	RAV. G7441.200921	RAV. G7641.200945	RAV. G7641.200006	RAV. G7641.201041	RAV. G7641.200907	RAV. G7641.200689	RAV. G7641.201010	RAV. G7641.201089	RAV. G7641.200761	RAV. G7645.201232	RAV. G7645.200914	RAV. G7645.200990	RAV. G8645.201249	SFA. GA441.200976	SFA. GA441.201126	SFA. GA441.202000	SFA. GA641.201027	SFA. GA641.201096	SFA. GA641.200952	SFA. GA641.201058	SFA. GA645.200600			
			●	●			●		●	●	●	●																														
#		D.R	N	Descrizione	Description	Beschreibung	Description	Descripción																																		

1	✓		770790050	Utensile cuneo	Wedge tool	Keilwerkzeug	Outil cale	Útil cuña				
2	✓		B5717000	Fascetta stringitubo	Hose clamp	Lippklampe	Collier de serrage	Abrazadera para tubos				
3	✓		203028	TE M8x10	TE M8x10 bolt	Schraube TE M8x10	Vis TE M8x10	Tornillo TE M8x10				
4	✓		203206	TE M5x8	TE M5x8 bolt	Schraube TE M5x8	Vis TE M5x8	Tornillo TE M5x8				
5	✓		206064	TCEI M10x45	TCEI M10x45 bolt	Schraube TCEI M10x45	Vis TCEI M10x45	Tornillo TCEI M10x45				
6	✓		206229	TCEI M5x10	TCEI M5x10 bolt	Schraube TCEI M5x10	Vis TCEI M5x10	Tornillo TCEI M5x10				
7	✓		228022	Dado autobloccante basso M10	M10 jam self-locking nut	Untere selbstsichernde Mutter M10	Écrou auto-bloquant bas M10	Tuerca autobloccante baja M10				
8	✓		228040	Dado autobloccante M16	M16 self-locking nut	Selbstsichernde Mutter M16	Écrou auto-bloquant M16	Tuerca autobloccante M16				
9	✓		236020	Rondella piana 17	17 flat washer	Ebene Unterlagsscheibe 17	Rondelle plane 17	Arandela plana 17				
10	✓		237510	Rondella di spessore D.20	D.20 shim washer	Beilagscheibe D.20	Rondelle d'épaisseur D.20	Arandela de espesor D.20				
11	✓		238026	Rondella elastica 5,3	5.3 spring washer	Elastische Unterlagsscheibe 5,3	Rondelle élastique 5,3	Arandela elástica 5,3				
12	✓		251118	Insero filettato M5	M5 threaded insert	Gewindeinsatz M5	Renfort fileté M5	Insero roscado M5				
13	✓		271229	TBEI M5x10	TBEI M5x10 bolt	Schraube TBEI M5x10	Vis TBEI M5x10	Tornillo TBEI M5x10				
14	✓		317006	Tube rilsan 6x4 nero L=2130	6x4 black rilsan hose L=2130	Rilsan Rohr 6x4 schwarz L=2130	Tuyau rilsan 6x4 noir L=2130	Tubo rilsan 6x4 negro L=2130				
15	✓		599417	Spiralite	Spiral wire containment cable	Spiralenleitung für Kabeleindämmung	Spirale porte-câble	Porta-cable de espiral				
16	✓		730019430	Staffa	Bracket	Bügel	Bride	Brida				
17	✓		770713040	Staffa fissaggio copertura	Cover fixing bracket	Abdeckungsbefestigungsbügel	Bride fixation couvercle	Brida fijación tapa				
18	✓		770713180	Copertura cilindro	Cylinder cover	Zylinderabdeckung	Couverture cylindre	Cobertura cilindro				
19	✓		770714200	Perno di centraggio	Centring pin	Zentrierzapfen	Pivot de centrage	Perno de centrage				
20	✓		770790103	Braccio supporto cuneo	Wedge support arm	Keilträgerarm	Bras support cale	Brazo soporte cuña				
21	✓		770710303	Braccio supporto cuneo	Wedge support arm	Keilträgerarm	Bras support cale	Brazo soporte cuña				
22	✓		730071090	Kit perno	Pin kit	Zapfenset	Kit pivot	Kit perno				
23	✓		770790310	Comando valvola	Valve control	Ventilsbefehl	Commande soupape	Comando válvula				

#		D.R	N	Descrizione	Description	Beschreibung	Description	Descripción		
---	---	-----	---	-------------	-------------	--------------	-------------	-------------	---	---

24	✓		206360	TCEI M4x45	TCEI M4x45 bolt	Schraube TCEI M4x45	Vis TCEI M4x45	Tornillo TCEI M4x45		
25	✓		228036	Dado autobloccante basso M4	M4 jam self-locking nut	Untere selbstsichernde Mutter M4	Écrou auto-bloquant bas M4	Tuerca autobloccante baja M4		
26	✓		236025	Rosetta d. 4,3x9x0,8	D. 4.3x9x0.8 washer	Unterlegscheibe d. 4,3x9x0,8	Rondelle d. 4,3x9x0,8	Arandela d. 4,3x9x0,8		
27	✓		770710651	Carter valvola	Valve guard	Ventilgehäuse	Carter soupape	Cárter válvula		
28	✓		770711870	Distanziale per valvola	Spacer for valve	Abstandsstück für Ventil	Entretoise pour soupape	Distanciador para válvula		
29	✓		770711881	Carter valvola plus	Plus valve guard	Plus-Ventilgehäuse	Carter soupape	Cárter válvula Plus		
30	✓		770790421	Valvola comando cilindri	Cylinders control valve	Zylindersteuerventil	Soupape commande cylindres	Válvula mando cilindros		
31	✓		770790360	Braccio esagonale con rullo	Hex-nut arm with roller	Sechswinklingarm mit Rolle	Bras hexagonal avec rouleau	Brazo hexagonal con rodillo		
32	✓		770790150	Rullo	Roller	Rolle	Rouleau	Rodillo		
33	✓		770710430	Braccio esagonale	Hex-nut arm	Sechswinklingarm	Bras hexagonal	Brazo hexagonal		
34	✓		321201	Pistoncino a molla	Spring piston	Kolbenhalter	Piston à ressort	Pistón de resorte		
35	✓		203129	TE M8x12	TE M8x12 bolt	Schraube TE M8x12	Vis TE M8x12	Tornillo TE M8x12		
36	✓		770790591	Gruppo colonna	Column assembly	Säulesatz	Ensemble colonne	Conjunto columna		
37	✓		770790621	Supporto bracci	Arms support	Armsträger	Support bras	Soporte brazos		
38	✓		770713231	Supporto bracci	Arms support	Armsträger	Support bras	Soporte brazos		
39	✓		770714040	Lama di spessoramento	Shim blade	Beilagefeder	Lame d'épaisseur	Cuchilla de espesor		
40	✓		770713000	Piatto	Plate	Platte	Plateau	Plaque		
41	✓		B7298000	Pomolo D.25	D.25 knob	Handgriff D.25	Poignée D.25	Pomo D.25		
42	✓		770714010	Angolare	Angle bar	Winkel	Angulaire	Angular		
43	✓		730071100	Kit viti e dadi	Bolts and nuts kit	Schrauben- und Mutternset	Kit vis et écrous	Kit tornillos y tuercas		
44	✓		730071130	Kit chiusura pattini e viti	Sliding blocks and bolts closing kit	Schlitten und Schrauben Verschlussset	Kit fermeture patines et vis	Kit cierre patines y tornillos		
45	✓		770790720	Kit lardone lungo e corto	Long and short gib kit	Lange und kurze Leiste Set	Kit lardon long et court	Kit chaveta larga y corta		
46	✓		770790672	Cilindro D.80	D. 80 cylinder	Zylinder D.80	Cylindre D. 80	Cilindro D. 80		
47	✓		325178	Raccordo	Fitting	Anschluss	Raccord	Empalme		
48	✓		GU6130	Kit guarnizione cilindro D.80	Cylinder gasket kit D.80	Zylinderdichtungenset D.80	Kit joint cylindre D.80	Kit junta cilindro D.80		
49	✓		770790700	Gruppo braccio pressore	Pusher arm assembly	Druckarmsatz	Ensemble bras presseur	Conjunto brazo prensador		
50	✓		770711671	Braccio pressore	Pusher arm	Drückerarm	Bras presseur	Brazo prensador		
51	✓		770713400	Stelo per pressore	Rod for pusher	Stange für Niederhalter	Tige pour presseur	Vástago para prensador		
52	✓		237043	Rondella piana 10x30x2,5	10x30x2.5 flat washer	Ebene Unterlagsscheibe 10x30x2,5	Rondelle plane 10x30x2,5	Arandela plana 10x30x2,5		
53	✓		228012	Dado autobloccante M10	M10 self-locking nut	Selbstsichernde Mutter M10	Écrou auto-bloquant M10	Tuerca autobloccante M10		

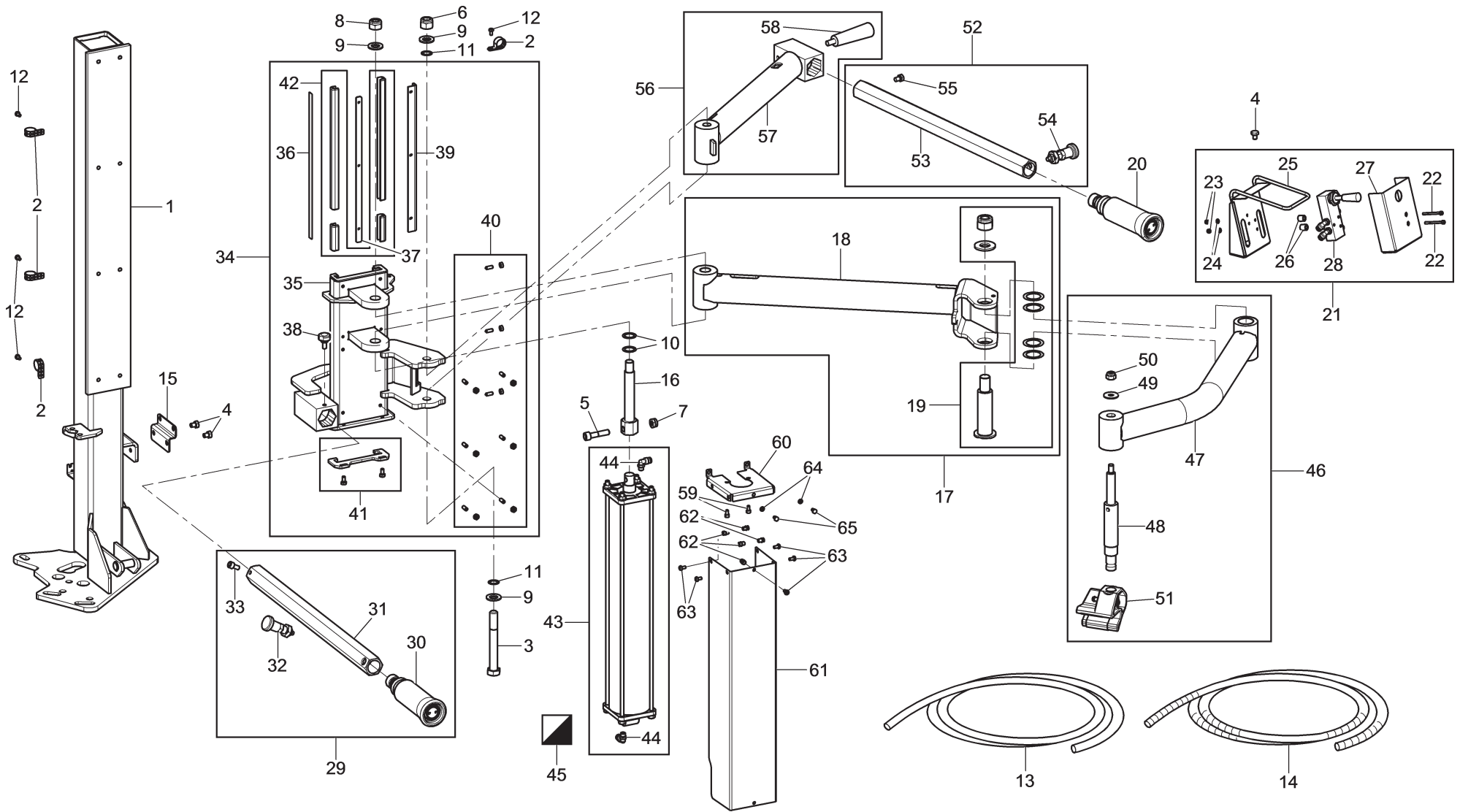

ROT. HP441.201102	ROT. HP641.200888	ROT. HP641.201034	ROT. HP641.200891	ROT. HP641.200785	ROT.HP641.201063 ROT.HP641.201788	ROT. HP641.201072	ROT. HP641.201065	ROT. HP641.201897	ROT.HP643.200894 ROT.HP643.201881	ROT. HP643.201133	ROT. HP643.200983	RAV. G7441.201140	RAV. G7441.200969	RAV. G7441.201119	RAV. G7441.200716	RAV. G7441.200877	RAV. G7441.200921	RAV. G7641.200945	RAV. G7641.200006	RAV. G7641.201041	RAV.G7641.200907 RAV.G7641.200683	RAV. G7641.201010	RAV. G7641.201089	RAV. G7641.200761	RAV. G7645.201232	RAV. G7645.200914	RAV. G7645.200990	RAV. G8645.201249	SPA. GA441.200976	SPA. GA441.201126	SPA. GA441.202000	SPA. GA641.201027	SPA. GA641.201096	SPA. GA641.200952	SPA. GA641.201058	SPA. GA645.200600
----------------------	----------------------	----------------------	----------------------	----------------------	--------------------------------------	----------------------	----------------------	----------------------	--------------------------------------	----------------------	----------------------	----------------------	----------------------	----------------------	----------------------	----------------------	----------------------	----------------------	----------------------	----------------------	--------------------------------------	----------------------	----------------------	----------------------	----------------------	----------------------	----------------------	----------------------	----------------------	----------------------	----------------------	----------------------	----------------------	----------------------	----------------------	----------------------



LISTA DEI COMPONENTI - LIST OF COMPONENTS - TEILELISTE  
LISTE DES PIECES DETACHEES - LISTA DE PIEZAS



Tavola N°16B - Rev. 0



770790990

PREMITALLONE  
BEAD PRESS  
WULSTABDRÜCKER  
POUSSE-TALON  
PRESIONATALÓN

Pag. 138 di 235

**Tavola N°16B - Rev. 0**
**770790990**

#		D.R	N	Descrizione	Description	Beschreibung	Description	Descripción		
1	✓		770790591	Gruppo colonna	Column assembly	Säulesatz	Ensemble colonne	Conjunto columna		
2	✓		B5717000	Fascetta stringitubo	Hose clamp	Lippklampe	Collier de serrage	Abrazadera para tubos		
3	✓		201379	TE M16x130	TE M16x130 bolt	Schraube TE M16x130	Vis TE M16x130	Tornillo TE M16x130		
4	✓		203028	TE M8x10	TE M8x10 bolt	Schraube TE M8x10	Vis TE M8x10	Tornillo TE M8x10		
5	✓		206064	TCEI M10x45	TCEI M10x45 bolt	Schraube TCEI M10x45	Vis TCEI M10x45	Tornillo TCEI M10x45		
6	✓		228013	Dado autobloccante M16	M16 self-locking nut	Selbstsichernde Mutter M16	Écrou auto-bloquant M16	Tuerca autobloccante M16		
7	✓		228022	Dado autobloccante basso M10	M10 jam self-locking nut	Untere selbstsichernde Mutter M10	Écrou auto-bloquant bas M10	Tuerca autobloccante baja M10		
8	✓		228040	Dado autobloccante M16	M16 self-locking nut	Selbstsichernde Mutter M16	Écrou auto-bloquant M16	Tuerca autobloccante M16		
9	✓		236020	Rondella piana 17	17 flat washer	Ebene Unterlagsscheibe 17	Rondelle plane 17	Arandela plana 17		
10	✓		237510	Rondella di spessore D.20	D.20 shim washer	Beilagscheibe D.20	Rondelle d'épaisseur D.20	Arandela de espesor D.20		
11	✓		237537	Rondella di spessoramento	Shim washer	Beilagscheibe	Rondelle d'épaisseur	Arandela de espesor		
12	✓		271229	TBEI M5x10	TBEI M5x10 bolt	Schraube TBEI M5x10	Vis TBEI M5x10	Tornillo TBEI M5x10		
13	✓		317006	Tubo rilsan 6x4 nero L=2130	6x4 black rilsan hose L=2130	Rilsan Rohr 6x4 schwarz L=2130	Tuyau rilsan 6x4 noir L=2130	Tubo rilsan 6x4 negro L=2130		
14	✓		599417	Spiralite	Spiral wire containment cable	Spiralenleitung für Kabelindämmung	Spirale porte-câble	Porta-cable de espiral		
15	✓		730019430	Staffa	Bracket	Bügel	Bride	Brida		
16	✓		770714200	Perno di centraggio	Centring pin	Zentrierzapfen	Pivot de centrage	Perno de centrage		
17	✓		770790103	Braccio supporto cuneo	Wedge support arm	Keilträgerarm	Bras support cale	Brazo soporte cuña		
18	✓		770710303	Braccio supporto cuneo	Wedge support arm	Keilträgerarm	Bras support cale	Brazo soporte cuña		
19	✓		730071090	Kit perno	Pin kit	Zapfenset	Kit pivot	Kit perno		
20	✓		770790150	Rullo	Roller	Rolle	Rouleau	Rodillo		
21	✓		770790310	Comando valvola	Valve control	Ventilsbefehl	Commande soupape	Comando válvula		
22	✓		206360	TCEI M4x45	TCEI M4x45 bolt	Schraube TCEI M4x45	Vis TCEI M4x45	Tornillo TCEI M4x45		
23	✓		228036	Dado autobloccante basso M4	M4 jam self-locking nut	Untere selbstsichernde Mutter M4	Écrou auto-bloquant bas M4	Tuerca autobloccante baja M4		
24	✓		236025	Rosetta d. 4,3x9x0,8	D. 4.3x9x0.8 washer	Unterlegscheibe d. 4,3x9x0,8	Rondelle d. 4,3x9x0,8	Arandela d. 4,3x9x0,8		
25	✓		770710651	Carter valvola	Valve guard	Ventilgehäuse	Carter soupape	Cárter válvula		
26	✓		770711870	Distanziale per valvola	Spacer for valve	Abstandsstück für Ventil	Entretoise pour soupape	Distanciador para válvula		
27	✓		770711881	Carter valvola plus	Plus valve guard	Plus-Ventilgehäuse	Carter soupape	Cárter válvula Plus		
28	✓		770790421	Valvola comando cilindri	Cylinders control valve	Zylindersteuerventil	Soupape commande cylindres	Válvula mando cilindros		
29	✓		770790360	Braccio esagonale con rullo	Hex-nut arm with roller	Sechswinklingarm mit Rolle	Bras hexagonal avec rouleau	Brazo hexagonal con rodillo		
30	✓		770790150	Rullo	Roller	Rolle	Rouleau	Rodillo		
31	✓		770710430	Braccio esagonale	Hex-nut arm	Sechswinklingarm	Bras hexagonal	Brazo hexagonal		

#		D.R	N	Descrizione	Description	Beschreibung	Description	Descripción		
---	---	-----	---	-------------	-------------	--------------	-------------	-------------	---	---

32	✓		321201	Pistoncino a molla	Spring piston	Kolbenhalter	Piston à ressort	Pistón de resorte		
33	✓		203129	TE M8x12	TE M8x12 bolt	Schraube TE M8x12	Vis TE M8x12	Tornillo TE M8x12		
34	✓		770790621	Supporto bracci	Arms support	Armsträger	Support bras	Soporte brazos		
35	✓		770713231	Supporto bracci	Arms support	Armsträger	Support bras	Soporte brazos		
36	✓		770714040	Lama di spessoramento	Shim blade	Beilagefeder	Lame d'épaisseur	Cuchilla de espesor		
37	✓		770713000	Piatto	Plate	Platte	Plateau	Plaque		
38	✓		B7298000	Pomolo D.25	D.25 knob	Handgriff D.25	Poignée D.25	Pomo D.25		
39	✓		770714010	Angolare	Angle bar	Winkel	Angulaire	Angular		
40	✓		730071100	Kit viti e dadi	Bolts and nuts kit	Schrauben- und Mutternset	Kit vis et écrous	Kit tornillos y tuercas		
41	✓		730071130	Kit chiusura pattini e viti	Sliding blocks and bolts closing kit	Schlitten und Schrauben Verschlussset	Kit fermeture patines et vis	Kit cierre patines y tornillos		
42	✓		770790720	Kit lardone lungo e corto	Long and short gib kit	Lange und kurze Leiste Set	Kit lardon long et court	Kit chaveta larga y corta		
43	✓		770790672	Cilindro D.80	D. 80 cylinder	Zylinder D.80	Cylindre D. 80	Cilindro D. 80		
44	✓		325178	Raccordo	Fitting	Anschluss	Raccord	Empalme		
45	✓		GU6130	Kit guarnizione cilindro D.80	Cylinder gasket kit D.80	Zylinderdichtungenset D.80	Kit joint cylindre D.80	Kit junta cilindro D.80		
46	✓		770790700	Gruppo braccio pressore	Pusher arm assembly	Druckarmsatz	Ensemble bras presseur	Conjunto brazo prensador		
47	✓		770711671	Braccio pressore	Pusher arm	Drückerarm	Bras presseur	Brazo prensador		
48	✓		770713400	Stelo per pressore	Rod for pusher	Stange für Niederhalter	Tige pour presseur	Vástago para prensador		
49	✓		237043	Rondella piana 10x30x2,5	10x30x2,5 flat washer	Ebene Unterlagsscheibe 10x30x2,5	Rondelle plane 10x30x2,5	Arandela plana 10x30x2,5		
50	✓		228012	Dado autobloccante M10	M10 self-locking nut	Selbstsichernde Mutter M10	Écrou auto-bloquant M10	Tuerca autobloccante M10		
51	✓		770790050	Utensile cuneo	Wedge tool	Keilwerkzeug	Outil cale	Útil cuña		
52	✓		770790710	Braccio esagonale	Hex-nut arm	Sechswinklingarm	Bras hexagonal	Brazo hexagonal		
53	✓		770710430	Braccio esagonale	Hex-nut arm	Sechswinklingarm	Bras hexagonal	Brazo hexagonal		
54	✓		321201	Pistoncino a molla	Spring piston	Kolbenhalter	Piston à ressort	Pistón de resorte		
55	✓		203129	TE M8x12	TE M8x12 bolt	Schraube TE M8x12	Vis TE M8x12	Tornillo TE M8x12		
56	✓		770790760	Gruppo braccio con supporto quadro	Arm assembly with cabinet support	Armsatz mit Tafelsträger	Ensemble bras avec support tableau	Conjunto brazo con soporte cuadro		
57	✓		770713950	Braccio supporto disco	Disc support arm	Scheibeträgerarm	Bras support disque	Brazo soporte disco		
58	✓		B1416700	Impugnatura con perno	Handgrip with pin	Handgriff mit Zapfen	Poignée avec pivot	Empuñadura con perno		
59	✓		206229	TCEI M5x10	TCEI M5x10 bolt	Schraube TCEI M5x10	Vis TCEI M5x10	Tornillo TCEI M5x10		
60	✓		770713040	Staffa fissaggio copertura	Cover fixing bracket	Abdeckungsbefestigungsbügel	Bride fixation couvercle	Brida fijación tapa		
61	✓		770713180	Copertura cilindro	Cylinder cover	Zylinderabdeckung	Couverture cylindre	Cobertura cilindro		
62	✓		251118	Inserto filettato M5	M5 threaded insert	Gewindeinsatz M5	Renfort fileté M5	Inserto roscado M5		
63	✓		271229	TBEI M5x10	TBEI M5x10 bolt	Schraube TBEI M5x10	Vis TBEI M5x10	Tornillo TBEI M5x10		



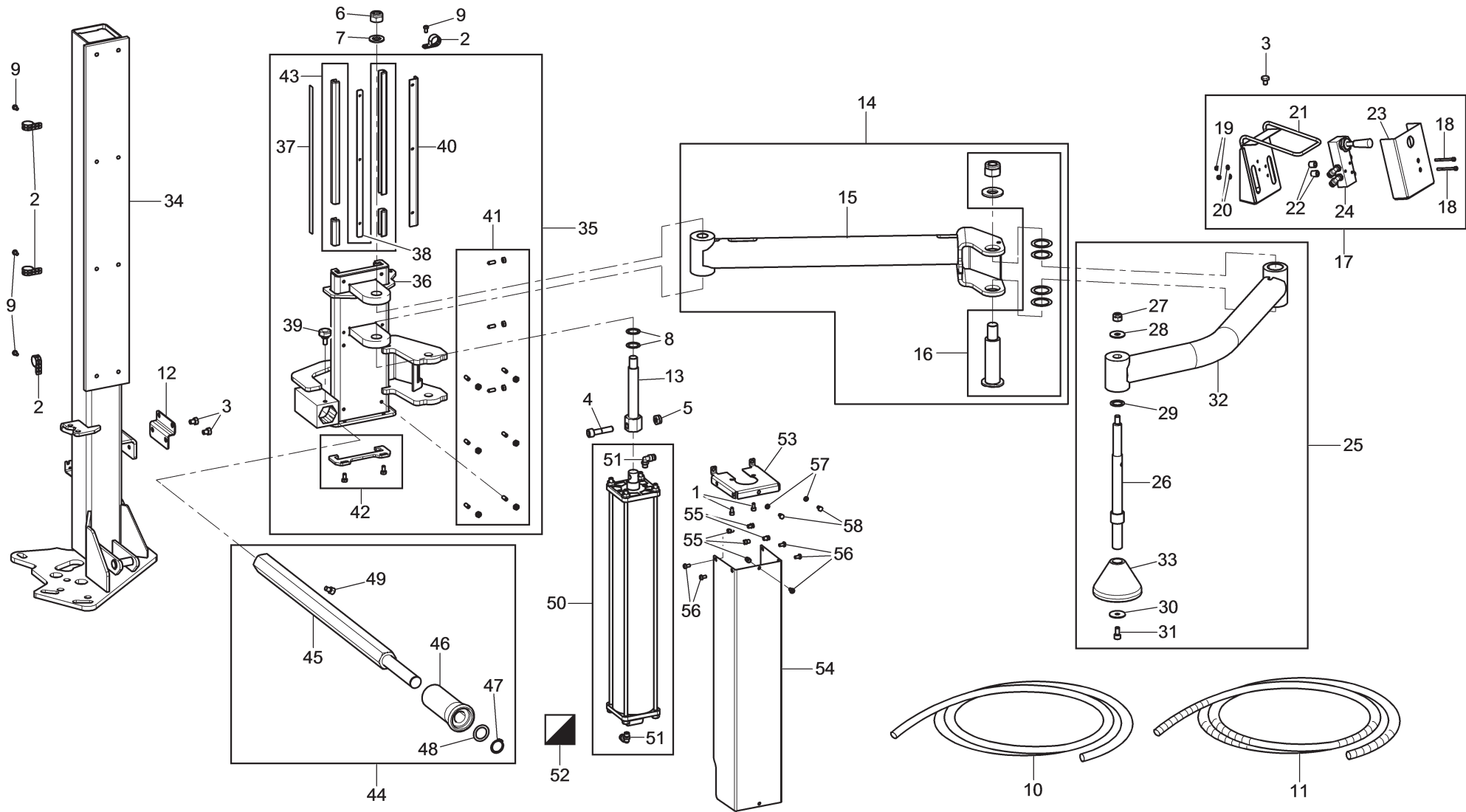

ROT. HP441.201102	ROT. HP641.200888	ROT. HP641.201034	ROT. HP641.200891	ROT. HP641.200785	ROT:HP641.201003	ROT:HP641.201788	ROT. HP641.201072	ROT. HP641.201065	ROT. HP641.201897	ROT:HP643.200894	ROT:HP643.201881	ROT. HP643.201133	ROT. HP643.200983	RAV. G7441.201140	RAV. G7441.200969	RAV. G7441.201119	RAV. G7441.200716	RAV. G7441.200877	RAV. G7441.200821	RAV. G7641.200945	RAV. G7641.200006	RAV. G7641.201041	RAV:G7641.200907	RAV:G7641.200683	RAV. G7641.201010	RAV. G7641.201089	RAV. G7641.200761	RAV. G7645.201232	RAV. G7645.200914	RAV. G7645.200990	RAV. G8645.201249	SPA. GA441.200976	SPA. GA441.201126	SPA. GA441.202000	SPA. GA641.201027	SPA. GA641.201096	SPA. GA641.200952	SPA. GA641.201058	SPA. GA645.200600
----------------------	----------------------	----------------------	----------------------	----------------------	------------------	------------------	----------------------	----------------------	----------------------	------------------	------------------	----------------------	----------------------	----------------------	----------------------	----------------------	----------------------	----------------------	----------------------	----------------------	----------------------	----------------------	------------------	------------------	----------------------	----------------------	----------------------	----------------------	----------------------	----------------------	----------------------	----------------------	----------------------	----------------------	----------------------	----------------------	----------------------	----------------------	----------------------



**LISTA DEI COMPONENTI - LIST OF COMPONENTS - TEILELISTE  
LISTE DES PIÈCES DÉTACHÉES - LISTA DE PIEZAS**



**Tavola N°16C - Rev. 0**

**770791010**



PREMITALLONE  
BEAD PRESS  
WULSTABDRÜCKER  
POUSSE-TALON  
PRESIONATALÓN



**Pag. 142 di 235**

#		D.R	N	Descrizione	Description	Beschreibung	Description	Descripción		
---	---	-----	---	-------------	-------------	--------------	-------------	-------------	---	---

1	✓		206229	TCEI M5x10	TCEI M5x10 bolt	Schraube TCEI M5x10	Vis TCEI M5x10	Tornillo TCEI M5x10		
2	✓		B5717000	Fascetta stringitubo	Hose clamp	Lippklampe	Collier de serrage	Abrazadera para tubos		
3	✓		203028	TE M8x10	TE M8x10 bolt	Schraube TE M8x10	Vis TE M8x10	Tornillo TE M8x10		
4	✓		206064	TCEI M10x45	TCEI M10x45 bolt	Schraube TCEI M10x45	Vis TCEI M10x45	Tornillo TCEI M10x45		
5	✓		228022	Dado autobloccante basso M10	M10 jam self-locking nut	Untere selbstsichernde Mutter M10	Écrou auto-bloquant bas M10	Tuerca autobloccante baja M10		
6	✓		228040	Dado autobloccante M16	M16 self-locking nut	Selbstsichernde Mutter M16	Écrou auto-bloquant M16	Tuerca autobloccante M16		
7	✓		236020	Rondella piana 17	17 flat washer	Ebene Unterlagsscheibe 17	Rondelle plane 17	Arandela plana 17		
8	✓		237510	Rondella di spessore D.20	D.20 shim washer	Beilagscheibe D.20	Rondelle d'épaisseur D.20	Arandela de espesor D.20		
9	✓		271229	TBEI M5x10	TBEI M5x10 bolt	Schraube TBEI M5x10	Vis TBEI M5x10	Tornillo TBEI M5x10		
10	✓		317006	Tubo rilsan 6x4 nero L=2130	6x4 black rilsan hose L=2130	Rilsan Rohr 6x4 schwarz L=2130	Tuyau rilsan 6x4 noir L=2130	Tubo rilsan 6x4 negro L=2130		
11	✓		599417	Spiralite	Spiral wire containment cable	Spiralenleitung für Kabeleindämmung	Spirale porte-câble	Porta-cable de espiral		
12	✓		730019430	Staffa	Bracket	Bügel	Bride	Brida		
13	✓		770714200	Perno di centraggio	Centring pin	Zentrierzapfen	Pivot de centrage	Perno de centrage		
14	✓		770790103	Braccio supporto cuneo	Wedge support arm	Keilträgerarm	Bras support cale	Brazo soporte cuña		
15	✓		770710303	Braccio supporto cuneo	Wedge support arm	Keilträgerarm	Bras support cale	Brazo soporte cuña		
16	✓		730071090	Kit perno	Pin kit	Zapfenset	Kit pivot	Kit perno		
17	✓		770790310	Comando valvola	Valve control	Ventilsbefehl	Commande soupape	Comando válvula		
18	✓		206360	TCEI M4x45	TCEI M4x45 bolt	Schraube TCEI M4x45	Vis TCEI M4x45	Tornillo TCEI M4x45		
19	✓		228036	Dado autobloccante basso M4	M4 jam self-locking nut	Untere selbstsichernde Mutter M4	Écrou auto-bloquant bas M4	Tuerca autobloccante baja M4		
20	✓		236025	Rosetta d. 4,3x9x0,8	D. 4.3x9x0.8 washer	Unterlegscheibe d. 4,3x9x0,8	Rondelle d. 4,3x9x0,8	Arandela d. 4,3x9x0,8		
21	✓		770710651	Carter valvola	Valve guard	Ventilgehäuse	Carter soupape	Cárter válvula		
22	✓		770711870	Distanziale per valvola	Spacer for valve	Abstandsstück für Ventil	Entretoise pour soupape	Distanciador para válvula		
23	✓		770711881	Carter valvola plus	Plus valve guard	Plus-Ventilgehäuse	Carter soupape	Cárter válvula Plus		
24	✓		770790421	Valvola comando cilindri	Cylinders control valve	Zylindersteuerventil	Soupape commande cylindres	Válvula mando cilindros		
25	✓		770790321	Gruppo braccio pressore	Pusher arm assembly	Druckarmsatz	Ensemble bras presseur	Conjunto brazo prensador		
26	✓		770714220	Stelo per pressore	Rod for pusher	Stange für Niederhalter	Tige pour presseur	Vástago para prensador		
27	✓		228012	Dado autobloccante M10	M10 self-locking nut	Selbstsichernde Mutter M10	Écrou auto-bloquant M10	Tuerca autobloccante M10		
28	✓		237043	Rondella piana 10x30x2,5	10x30x2.5 flat washer	Ebene Unterlagsscheibe 10x30x2,5	Rondelle plane 10x30x2,5	Arandela plana 10x30x2,5		
29	✓		237563	Rosetta 20x30x2	20x30x2 washer	Unterlegscheibe 20x30x2	Rondelle 20x30x2	Arandela 20x30x2		
30	✓		237037	Rondella piana tranciante 8x32x2,5	8x32x2.5 flat washer	Ebene Schneidscheibe 8x32x2,5	Rondelle plane 8x32x2,5	Arandela plana 8x32x2,5		

#		D.R	N	Descrizione	Description	Beschreibung	Description	Descripción		
---	---	-----	---	-------------	-------------	--------------	-------------	-------------	---	---



31	✓		206172	TCEI M8x16	TCEI M8x16 bolt	Schraube TCEI M8x16	Vis TCEI M8x16	Tornillo TCEI M8x16		
32	✓		770711671	Braccio pressore	Pusher arm	Drückerarm	Bras presseur	Brazo prensador		
33	✓		140820500	Cono pressore	Pusher cone	Druckkegel	Cône presseur	Cono prensador		
34	✓		770790591	Gruppo colonna	Column assembly	Säulesatz	Ensemble colonne	Conjunto columna		
35	✓		770790621	Supporto bracci	Arms support	Armsträger	Support bras	Soporte brazos		
36	✓		770713231	Supporto bracci	Arms support	Armsträger	Support bras	Soporte brazos		
37	✓		770714040	Lama di spessoramento	Shim blade	Beilagefeder	Lame d'épaisseur	Cuchilla de espesor		
38	✓		770713000	Piatto	Plate	Platte	Plateau	Plaque		
39	✓		B7298000	Pomolo D.25	D.25 knob	Handgriff D.25	Poignée D.25	Pomo D.25		
40	✓		770714010	Angolare	Angle bar	Winkel	Angulaire	Angular		
41	✓		730071100	Kit viti e dadi	Bolts and nuts kit	Schrauben- und Mutternset	Kit vis et écrous	Kit tornillos y tuercas		
42	✓		730071130	Kit chiusura pattini e viti	Sliding blocks and bolts closing kit	Schlitten und Schrauben Ver- schlussset	Kit fermeture patines et vis	Kit cierre patines y tornillos		
43	✓		770790720	Kit lardone lungo e corto	Long and short gib kit	Lange und kurze Leiste Set	Kit lardon long et court	Kit chaveta larga y corta		
44	✓		770790660	Braccio esagonale	Hex-nut arm	Sechswinklingarm	Bras hexagonal	Brazo hexagonal		
45	✓		770713310	Esagono porta rullo	Roller holder hex-nut	Rolleträger Sechskant	Hexagone porte-rouleau	Hexágono porta rodillo		
46	✓		140841360	Rullo	Roller	Rolle	Rouleau	Rodillo		
47	✓		243013	Seeger esterno 25	External clip ring 25	Externer Seeger 25	Anneau de retenue extérieur 25	Seeger externo 25		
48	✓		237511	Rondella di spessore	Shim washer	Beilagscheibe	Rondelle d'épaisseur	Arandela de espesor		
49	✓		203129	TE M8x12	TE M8x12 bolt	Schraube TE M8x12	Vis TE M8x12	Tornillo TE M8x12		
50	✓		770790672	Cilindro D.80	D. 80 cylinder	Zylinder D.80	Cylindre D. 80	Cilindro D. 80		
51	✓		325178	Raccordo	Fitting	Anschluss	Raccord	Empalme		
52	✓		GU6130	Kit guarnizione cilindro D.80	Cylinder gasket kit D.80	Zylinderdichtungenset D.80	Kit joint cylindre D.80	Kit junta cilindro D.80		
53	✓		770713040	Staffa fissaggio copertura	Cover fixing bracket	Abdeckungsbefestigungsbügel	Bride fixation couvercle	Brida fijación tapa		
54	✓		770713180	Copertura cilindro	Cylinder cover	Zylinderabdeckung	Couverture cylindre	Cobertura cilindro		
55	✓		251118	Insero filettato M5	M5 threaded insert	Gewindeinsatz M5	Renfort fileté M5	Insero roscado M5		
56	✓		271229	TBEI M5x10	TBEI M5x10 bolt	Schraube TBEI M5x10	Vis TBEI M5x10	Tornillo TBEI M5x10		
57	✓		238026	Rondella elastica 5.3	5.3 spring washer	Elastische Unterlagsscheibe 5.3	Rondelle élastique 5,3	Arandela elástica 5,3		
58	✓		203206	TE M5x8	TE M5x8 bolt	Schraube TE M5x8	Vis TE M5x8	Tornillo TE M5x8		



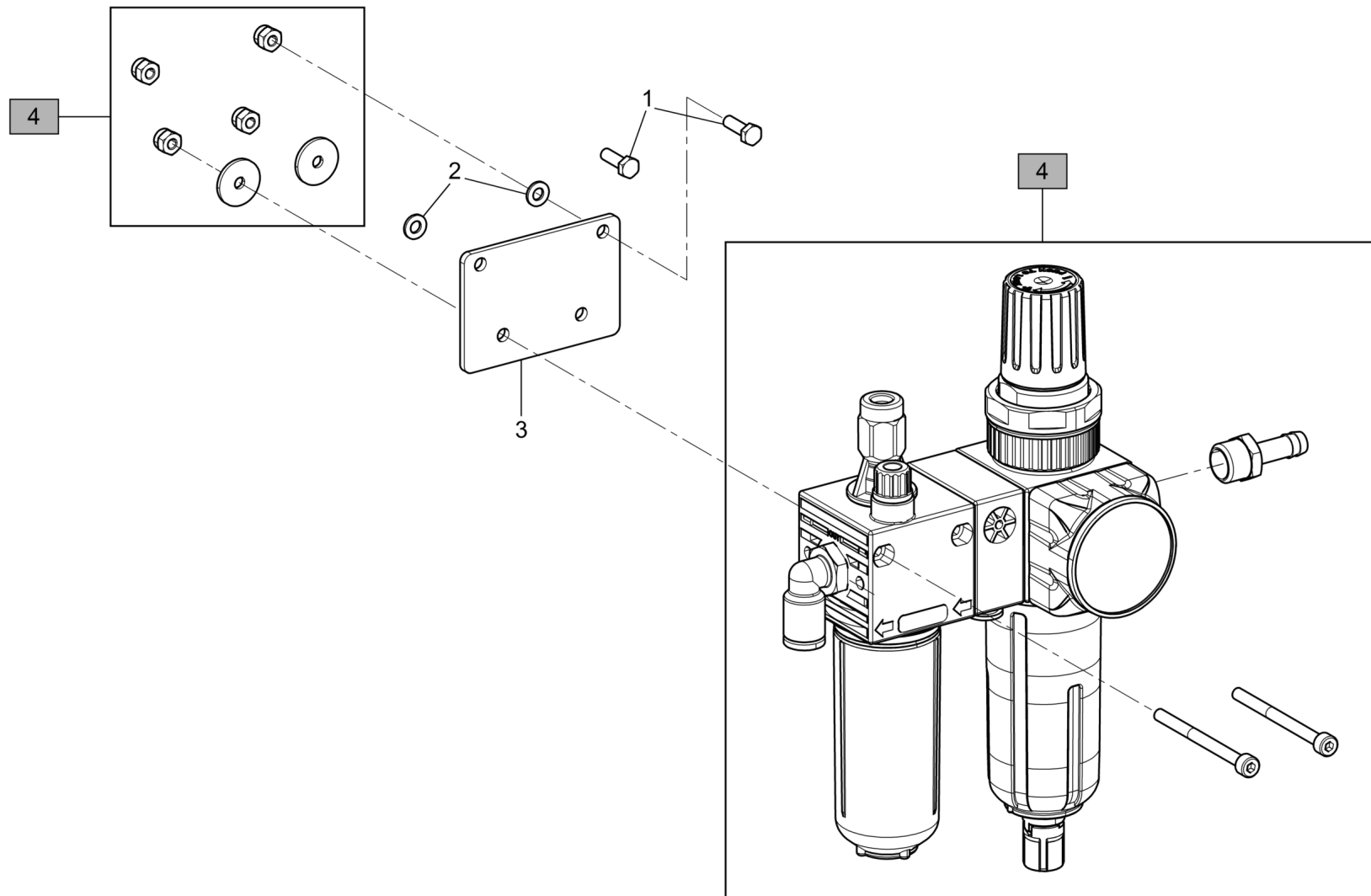



ROT. HP441.201102	ROT. HP641.200838	ROT. HF641.201034	ROT. HP641.200891	ROT. HF641.200785	ROT.HP641.201063 ROT.HP641.201788	ROT. HP641.201072	ROT. HP641.201065	ROT. HP641.201897	ROT.HP643.200884 ROT.HP643.201881	ROT. HP643.201133	ROT. HF643.200983	RAV. G7441.201140	RAV. G7441.200969	RAV. G7441.201119	RAV. G7441.200716	RAV. G7441.200877	RAV. G7441.200821	RAV. G7641.200945	RAV. G7641.200006	RAV. G7641.201041	RAV.G7641.200907 RAV.G7641.200683	RAV. G7641.201010	RAV. G7641.201089	RAV. G7641.200761	RAV. G7645.201232	RAV. G7645.200914	RAV. G7645.200990	RAV. G8645.201249	SFA. GA441.200976	SPA. GA441.201126	SFA. GA441.202000	SPA. GA641.201027	SPA. GA641.201096	SPA. GA641.200952	SPA. GA641.201058	SPA. GA645.200600				
			•				•		•	•	•						•				•			•																
		<b>LISTA DEI COMPONENTI - LIST OF COMPONENTS - TEILELISTE</b> <b>LISTE DES PIÈCES DÉTACHÉES - LISTA DE PIEZAS</b>																			KIT CONDIZIONAMENTO ARIA AIR CONDITIONING KIT LUFT-KLIMATISIERUNGSSET KIT CONDITIONNEMENT AIR KIT ACONDICIONAMIENTO AIRE																			
		Tavola N°17B - Rev. 1									730190020									Pag. 147 di 235																				

 <b>VSG</b> <small>VEHICLE SERVICE GROUP</small> <small>a  company</small>	<b>LISTA DEI COMPONENTI - LIST OF COMPONENTS - TEILELISTE</b> <b>LISTE DES PIECES DETACHEES - LISTA DE PIEZAS</b>					KIT CONDIZIONAMENTO ARIA AIR CONDITIONING KIT LUFK- KLIMATISIERUNGSSSET KIT CONDITIONNEMENT AIR KIT ACONDICIONAMIENTO AIRE										<b>Pag. 148 di 235</b>  <span style="font-size: 2em;">▶</span>  <span style="font-size: 2em;">▶</span>																							
	<b>Tavola N°17B - Rev. 1</b>					<b>730190020</b>																																	
ROT. HP441.201102	ROT. HP641.200938	ROT. HP641.201034	ROT. HP641.200891	ROT. HP641.200785	ROT. HP641.201003	ROT. HP641.201788	ROT. HP641.201072	ROT. HP641.201065	ROT. HP641.201997	ROT. HP643.200984	ROT. HP643.201881	ROT. HP643.201133	ROT. HP643.200983	RAV G7441.201140	RAV G7441.200969	RAV G7441.201119	RAV G7441.200716	RAV G7441.200877	RAV G7441.200921	RAV G7641.200945	RAV G7641.200006	RAV G7641.201041	RAV G7641.200907	RAV G7641.200689	RAV G7641.201010	RAV G7641.201089	RAV G7641.200761	RAV G7645.201232	RAV G7645.200914	RAV G7645.200990	RAV G8645.201249	SFA GA441.200976	SFA GA441.201126	SFA GA441.202000	SFA GAG41.201027	SFA GAG41.201096	SFA GAG41.200952	SFA GAG41.201058	SFA GAG45.200600
●	●	●	●	●	●	●	●	●	●	●	●	●	●	●	●	●	●	●	●	●	●	●	●	●	●	●	●	●	●	●	●	●	●	●	●	●	●	●	●
<b>#</b>		<b>D.R</b>	<b>N</b>	<b>Descrizione</b>			<b>Description</b>			<b>Beschreibung</b>			<b>Description</b>			<b>Descripción</b>					<b>▶</b>	<b>▶</b>																	

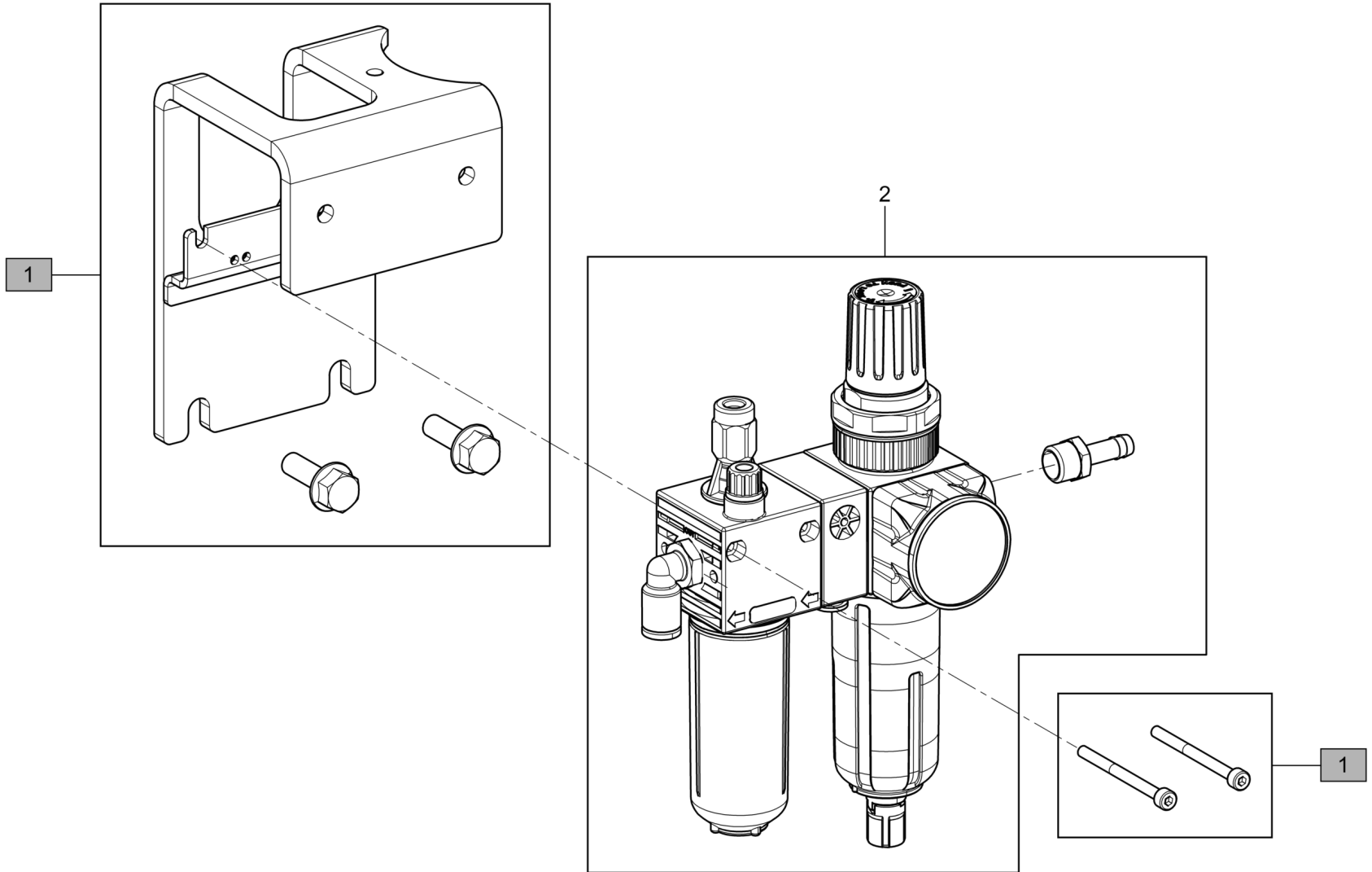

1	✓		203160	TE M4x12	Bolt TE M4x12	Schraube TE M4x12	Vis TE M4x12	Tornillo TE M4x12						
2	✓		236025	Rosetta d. 4,3x9x0,8	Washer d. 4.3x9x0.8	Unterlegscheibe d. 4,3x9x0,8	Rondelle d. 4,3x9x0,8	Arandela d. 4,3x9x0,8						
3	✓		730030590	Staffa supporto filtro	Filter support bracket	Filter-Trägersbügel	Bride support filtre	Brida soporte filtro						
4	✓		730071300	Kit ricambio gruppo filtro riduttore lubrificatore	Lubricator reduction gear filter assembly spare kit	Ersatzteilenset für Schmieruntersetzer-Filteratz	Kit de rechange ensemble filtre réducteur lubrificateur	Kit repuesto conjunto filtro reductor lubrificador						



ROT. HP441.201102	ROT. HP641.200888	ROT. HP641.201034	ROT. HP641.200891	ROT. HP641.200785	ROT:HP641.201063 ROT:HP641.201788	ROT. HP641.201072	ROT. HP641.201065	ROT. HP641.201897	ROT:HP643.200884 ROT:HP643.201881	ROT. HP643.201133	ROT. HP643.200983	RAV. G7441.201140	RAV. G7441.200969	RAV. G7441.201119	RAV. G7441.200716	RAV. G7441.200877	RAV. G7441.200921	RAV. G7641.200945	RAV. G7641.200006	RAV. G7641.201041	RAV:G7641.200907 RAV:G7641.200683	RAV. G7641.201010	RAV. G7641.201089	RAV. G7641.200761	RAV. G7645.201232	RAV. G7645.200914	RAV. G7645.200990	RAV. G8645.201249	SFA. GA441.200976	SPA. GA441.201126	SFA. GA441.202000	SPA. GA641.201027	SPA. GA641.201096	SPA. GA641.200952	SPA. GA641.201058	SPA. GA645.200600			
																									•	•													•
		<b>LISTA DEI COMPONENTI - LIST OF COMPONENTS - TEILELISTE</b> <b>LISTE DES PIÈCES DÉTACHÉES - LISTA DE PIEZAS</b>															KIT CONDIZIONAMENTO ARIA AIR CONDITIONING KIT LUFT-KLIMATISIERUNGSSET KIT CONDITIONNEMENT AIR KIT ACONDICIONAMIENTO AIRE																						
		<b>Tavola N°17C - Rev. 1</b>			<b>730190030</b>																																		
														<b>Pag. 149 di 235</b>																									

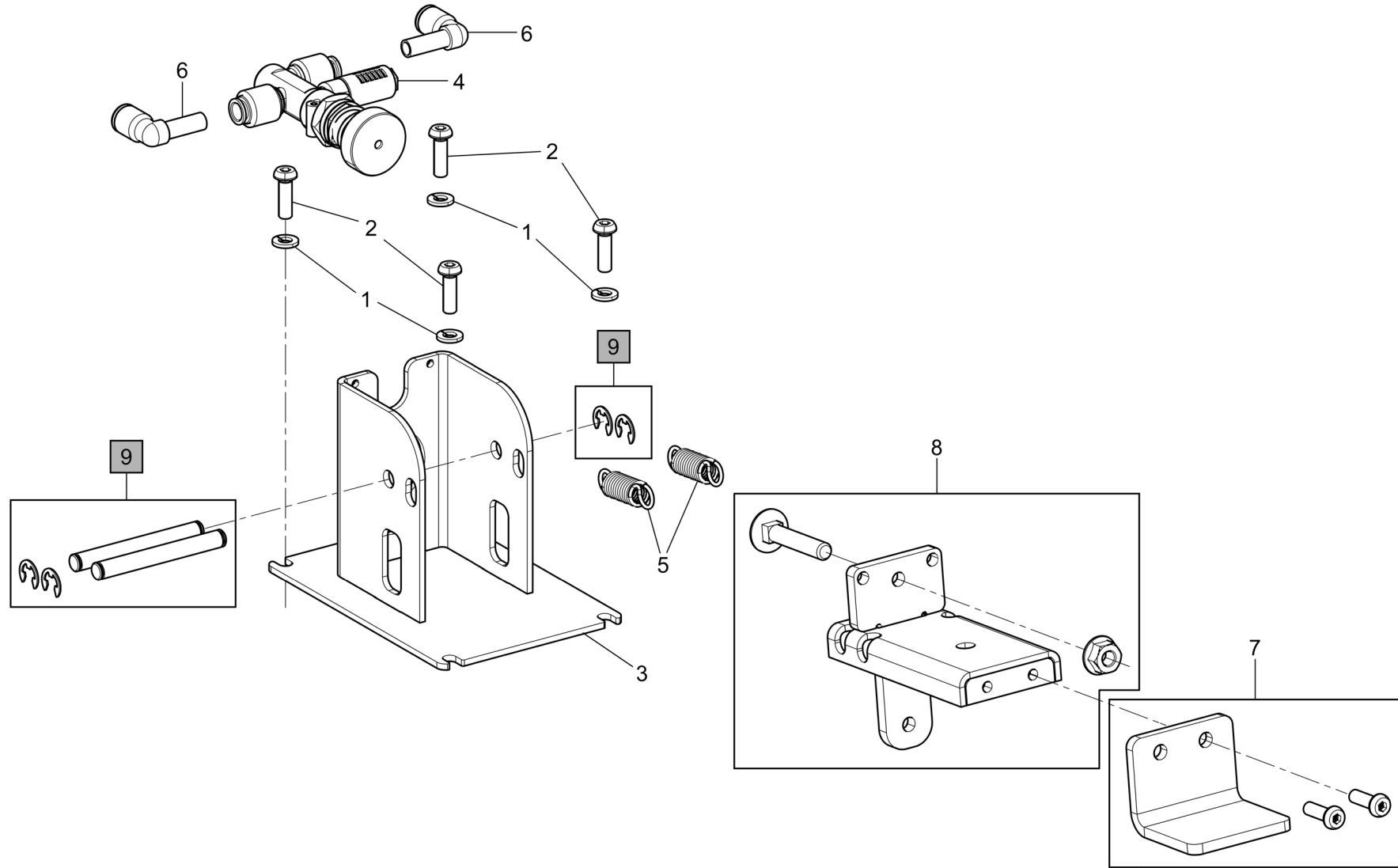



ROT. HP441.201102	ROT. HP641.200838	ROT. HP641.201034	ROT. HP641.200891	ROT. HP641.200785	ROT. HP641.201003	ROT. HP641.201788	ROT. HP641.201072	ROT. HP641.201065	ROT. HP641.201897	ROT. HP643.200894	ROT. HP643.201881	ROT. HP643.201133	ROT. HP643.200983	RAV. G7441.201140	RAV. G7441.200969	RAV. G7441.201119	RAV. G7441.200716	RAV. G7441.200877	RAV. G7441.200821	RAV. G7641.200945	RAV. G7641.200006	RAV. G7641.201041	RAV. G7641.200907	RAV. G7641.200683	RAV. G7641.201010	RAV. G7641.201089	RAV. G7641.200761	RAV. G7645.201232	RAV. G7645.200914	RAV. G7645.200990	RAV. G8645.201249	SFA. GA441.200976	SFA. GA441.201126	SFA. GA441.202000	SFA. GA641.201027	SFA. GA641.201096	SFA. GA641.200952	SFA. GA641.201058	SFA. GA645.200600					
•	•		•	•	•			•	•	•			•		•	•			•	•			•		•											•								•
		<b>LISTA DEI COMPONENTI - LIST OF COMPONENTS - TEILELISTE</b> <b>LISTE DES PIÈCES DÉTACHÉES - LISTA DE PIEZAS</b>																			PEDALE DI GONFIAGGIO INFLATION PEDAL AUFPUMPEDALÜ PÉDALE DE GONFLAGE PEDAL DE INFLADO							 		<b>Pag. 151 di 235</b>														
		Tavola N°18A - Rev. 1						730097650																																				



LISTA DEI COMPONENTI - LIST OF COMPONENTS - TEILELISTE  
LISTE DES PIÉCES DÉTACHÉES - LISTA DE PIEZAS

PEDALE DI GONFIAGGIO  
INFLATION PEDAL  
AUFPUMPEDALU  
PÉDALE DE GONFLAGE  
PEDAL DE INFLADO

Tavola N°18A - Rev. 1

730097650

ROT. HP441.201102	ROT. HP641.200938	ROT. HP641.201034	ROT. HP641.200891	ROT. HP641.200785	ROT. HP641.201003	ROT. HP641.201788	ROT. HP641.201072	ROT. HP641.201065	ROT. HP641.201997	ROT. HP643.200984	ROT. HP643.201681	ROT. HP643.201133	ROT. HP643.200983	RAV. G7441.201140	RAV. G7441.200969	RAV. G7441.201119	RAV. G7441.200716	RAV. G7441.200877	RAV. G7441.200921	RAV. G7641.200945	RAV. G7641.200006	RAV. G7641.201041	RAV. G7641.200907	RAV. G7641.200889	RAV. G7641.201010	RAV. G7641.201089	RAV. G7641.200761	RAV. G7645.201232	RAV. G7645.200914	RAV. G7645.200990	RAV. G8645.201249	SFA. GA441.200976	SFA. GA441.201126	SFA. GA441.202000	SFA. GA641.201027	SFA. GA641.201096	SFA. GA641.200952	SFA. GA641.201058	SFA. GA645.200600		
●	●		●	●	●		●	●	●	●		●	●			●	●	●	●	●	●		●	●	●	●			●				●	●			●				●
#		D.R	N	Descrizione	Description	Beschreibung	Description	Descripción																																	

1	✓		238004	Rondella elastica 6,4	6.4 spring washer	Elastische Unterlagsscheibe 6,4	Rondelle elastique 6,4	Arandela elástica 6,4				
2	✓		271021	TBEI M6x20	TBEI M6x20 bolt	Schraube TBEI M6x20	Vis TBEI M6x20	Tornillo TBEI M6x20				
3	✓		B4103200	Supporto pedale verniciato	Painted pedal support	Lackierter Pedalsträger	Support pédales peint	Soporte pedales pintado				
4	✓		B7075001	Valvola stallonatore	Bead-breaker valve	Abdrückersventil	Soupape décolle-pneus	Válvula destalonador				
5	✓		918006	Molla TRZ 1,8x12x40,4	1.8x12x40.4 TRZ spring	Feder TRZ 1,8x12x40,4	Ressort TRZ 1,8x12x40,4	Resorte TRZ 1,8x12x40,4				
6	✓		325186	Raccordo pneumatico L fisso 8-8	8-8 L pneumatic fixed fitting	Pneumatischer L-Festanschluss 8-8	Raccord pneumatique L fixe 8-8	Empalme neumático en L fijo 8-8				
7	✓		790070720	Kit pedalino e viti	Pedal kit and bolts	Pedalsatz und Schrauben	Kit pédale et vis	Kit pedal y tornillos				
8	✓		790070730	Kit pedale di gonfiaggio	Inflation pedal kit	Set des Aufpumpspedals	Kit pédale de gonflage	Kit pedal de inflado				
9	✓		790070740	Kit perno pedale di gonfiaggio	Inflation pedal pin kit	Aufblaspedal-Stiftsset	Kit pivot pédale de gonflage	Kit perno pedal de inflado				





**LISTA DEI COMPONENTI - LIST OF COMPONENTS - TEILELISTE  
LISTE DES PIECES DETACHEES - LISTA DE PIEZAS**

*KIT PEDALE DI GONFIAGGIO  
INFLATION PEDAL KIT  
AUFPUMPPEDALSET  
KIT PÉDALE DE GONFLAGE  
KIT PEDAL DE INFLADO*

**Tavola N°18B - Rev. 0**

**730097770**

ROT. HP441.201102	ROT. HP641.200938	ROT. HP641.201034	ROT. HP641.200891	ROT. HP641.200785	ROT. HP641.201003	ROT. HP641.201788	ROT. HP641.201072	ROT. HP641.201065	ROT. HP641.201997	ROT. HP643.200984	ROT. HP643.201681	ROT. HP643.201133	ROT. HP643.200983	RAV. G7441.201140	RAV. G7441.200969	RAV. G7441.201119	RAV. G7441.200716	RAV. G7441.200877	RAV. G7441.200921	RAV. G7641.200945	RAV. G7641.200006	RAV. G7641.201041	RAV. G7641.200807	RAV. G7641.200689	RAV. G7641.201010	RAV. G7641.201089	RAV. G7641.200761	RAV. G7645.201232	RAV. G7645.200914	RAV. G7645.200990	RAV. G8645.201249	SFA. GA441.200976	SFA. GA441.201126	SFA. GA441.202000	SFA. GA641.201027	SFA. GA641.201096	SFA. GA641.200952	SFA. GA641.201058	SFA. GA645.200600
		●					●					●					●								●	●							●		●		●		

#		D.R	N	Descrizione	Description	Beschreibung	Description	Descripción	→	→
1	✓		B2729000	Pedalino	Pedal	Pedal	Pédale	Pedal		
2	✓		B3067000	Perno pedaliera di gonfiaggio	Inflation pedal board pin	Aufpumpspedalenzapfen	Pivot pédalier de gonflage	Perno pedalera de inflado		
3	✓		B4103200	Supporto pedale verniciato	Painted pedal support	Lackierter Pedalsträger	Support pédales peint	Soporte pedales pintado		
4	✓		B7075001	Valvola stallonatore	Bead-breaker valve	Abdrückersventil	Soupape décolle-pneus	Válvula destalonador		
5	✓		B7076001	Valvola motore	Motor valve	Motorventil	Soupape moteur	Válvula motor		
6	✓		238004	Rondella elastica 6,4	6.4 spring washer	Elastische Unterlagsscheibe 6,4	Rondelle elastique 6,4	Arandela elástica 6,4		
7	✓		271021	TBEI M6x20	TBEI M6x20 bolt	Schraube TBEI M6x20	Vis TBEI M6x20	Tornillo TBEI M6x20		
8	✓		299051	Anello di fermo D.7	D.7 stopper ring	Stoppring D.7	Anneau d'arrêt D.7	Anillo de seguro D.7		
9	✓		918006	Molla TRZ 1,8x12x40,4	1.8x12x40,4 TRZ spring	Feder TRZ 1,8x12x40,4	Ressort TRZ 1,8x12x40,4	Resorte TRZ 1,8x12x40,4		
10	✓		325186	Raccordo pneumatico L fisso 8-8	8-8 L pneumatic fixed fitting	Pneumatischer L-Festanschluss 8-8	Raccord pneumatique L fixe 8-8	Empalme neumático en L fijo 8-8		
11	✓		790070750	Kit pedale di gonfiaggio	Inflation pedal kit	Set des Aufpumpspedals	Kit pédale de gonflage	Kit pedal de inflado		
12	✓		251107	Inserto filettato M6	M6 threaded insert	Gewindeinsatz M6	Renfort fileté M6	Inserto roscado M6		

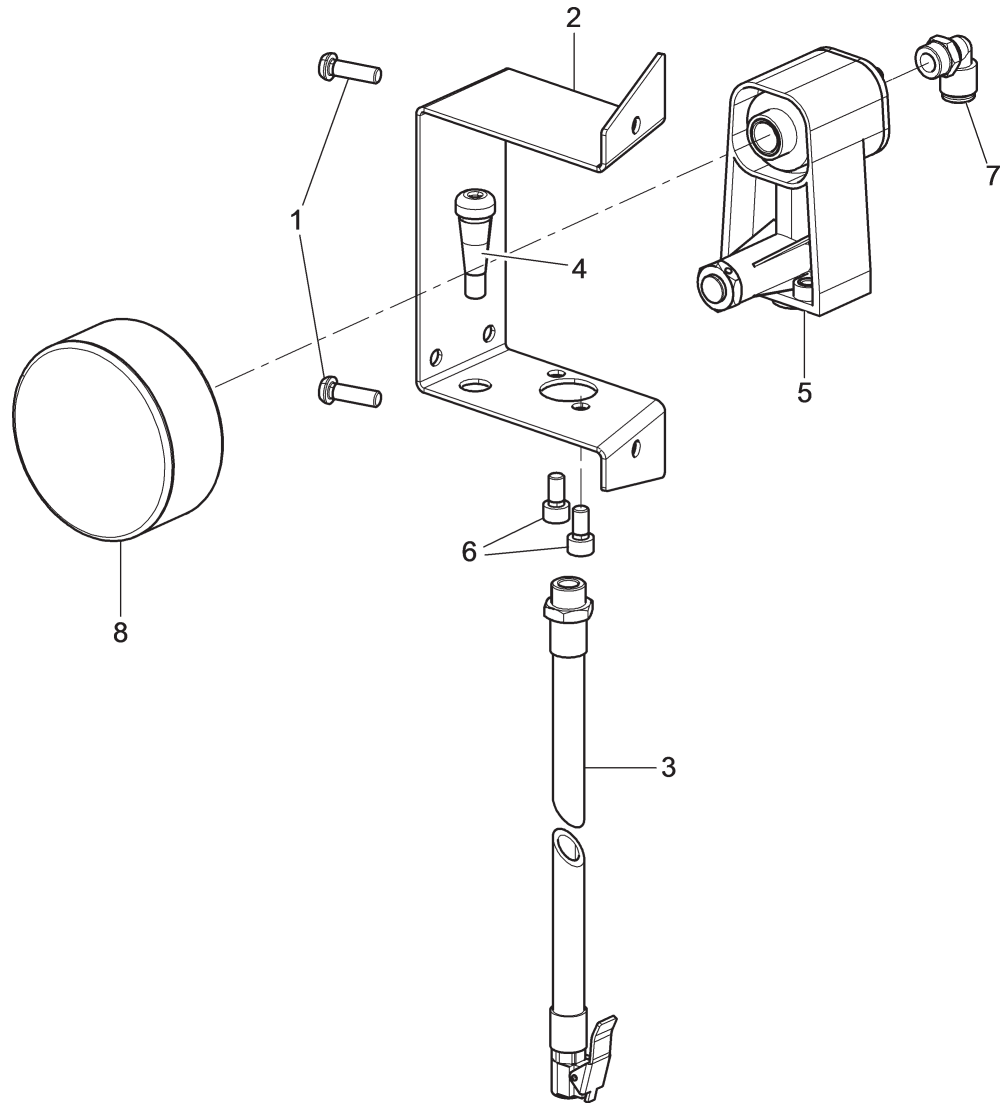

ROT. HP441.201102	ROT. HP641.200838	ROT. HF641.201034	ROT. HP641.200891	ROT. HF641.200785	ROT. HP641.201003	ROT. HP641.201788	ROT. HF641.201072	ROT. HF641.201065	ROT. HP641.201897	ROT. HP643.200684	ROT. HP643.201881	ROT. HP643.201133	ROT. HF643.200983	RAV. G7441.201140	RAV. G7441.200969	RAV. G7441.201119	RAV. G7441.200716	RAV. G7441.200877	RAV. G7441.200821	RAV. G7641.200945	RAV. G7641.200006	RAV. G7641.201041	RAV. G7641.200907	RAV. G7641.200683	RAV. G7641.201010	RAV. G7641.201089	RAV. G7641.200761	RAV. G7645.201232	RAV. G7645.200914	RAV. G7645.200990	RAV. G8645.201249	SFA. GA441.200976	SPA. GA441.201126	SFA. GA441.202000	SFA. GA641.201027	SFA. GA641.201096	SFA. GA641.200952	SFA. GA641.201058	SFA. GA645.200600					
•	•	•	•	•	•	•	•	•	•	•	•	•	•	•	•	•	•	•	•	•	•	•	•	•	•	•	•	•	•	•	•	•	•	•	•	•	•	•	•	•	•	•	•	•
		<b>LISTA DEI COMPONENTI - LIST OF COMPONENTS - TEILELISTE</b> <b>LISTE DES PIÈCES DÉTACHÉES - LISTA DE PIEZAS</b>																			KIT MANOMETRO DI GONFIAGGIO INFLATION PRESSURE GAUGE KIT LUFTDRUCKMESSER-SET KIT MANOMÈTRE DE GONFLAGE KIT MANÓMETRO DE INFLADO																							
		<b>Tavola N°19 - Rev. 0</b>											<b>730097660</b>								<b>Pag. 155 di 235</b>																							



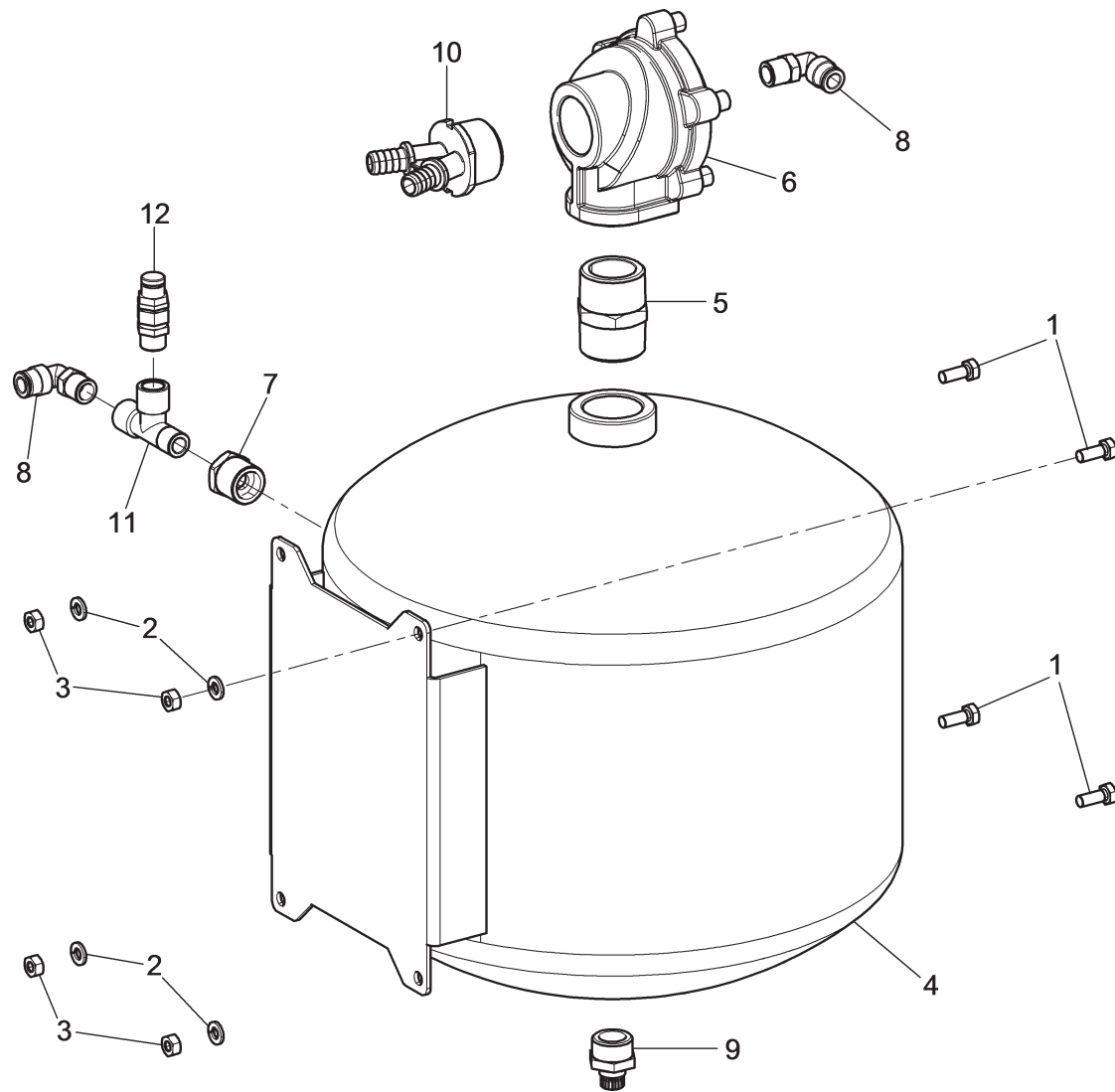

ROT. HP441.201102	ROT. HP641.200838	•	ROT. HP641.201034	ROT. HP641.200891	ROT. HP641.200785	ROT:HP641.201063	ROT:HP641.201788	•	ROT. HP641.201072	ROT. HP641.201065	ROT. HP641.201897	ROT:HP643.200884	ROT:HP643.201881	•	ROT. HP643.201133	ROT. HP643.200983	RAV. G7441.201140	RAV. G7441.200969	RAV. G7441.201119	RAV. G7441.200716	•	RAV. G7441.200877	RAV. G7441.200921	RAV. G7641.200945	RAV. G7641.200006	•	RAV. G7641.201041	RAV:G7641.200907	RAV:G7641.200683	RAV. G7641.201010	•	RAV. G7641.201089	RAV. G7641.200761	RAV. G7645.201232	RAV. G7645.200914	•	RAV. G7645.200990	RAV. G8645.201249	SFA. GA441.200976	SPA. GA441.201126	•	SFA. GA441.202000	SPA. GA641.201027	•	SFA. GA641.201096	SPA. GA641.200952	•	SPA. GA641.201058	SPA. GA645.200600
<b>LISTA DEI COMPONENTI - LIST OF COMPONENTS - TEILELISTE</b> <b>LISTE DES PIECES DETACHEES - LISTA DE PIEZAS</b>																								KIT SERBATOIO TANK KIT TANKSET KIT RÉSERVOIR KIT TANQUE						 																			
<b>Tavola N°20 - Rev. 0</b>												<b>730097780</b>												<b>Pag. 157 di 235</b>																									





LISTA DEI COMPONENTI - LIST OF COMPONENTS - TEILELISTE  
 LISTE DES PIÉCES DÉTACHÉES - LISTA DE PIEZAS

KIT SERBATOIO  
 TANK KIT  
 TANKSET  
 KIT RÉSERVOIR  
 KIT TANQUE

Tavola N°20 - Rev. 0

730097780

ROT. HP441.201102	ROT. HP641.200938	ROT. HP641.201034	ROT. HP641.200891	ROT. HP641.200785	ROT. HP641.201003	ROT. HP641.201788	ROT. HP641.201072	ROT. HP641.201065	ROT. HP641.201997	ROT. HP643.200984	ROT. HP643.201681	ROT. HP643.201133	ROT. HP643.200983	RAV. G7441.201140	RAV. G7441.200969	RAV. G7441.201119	RAV. G7441.200716	RAV. G7441.200877	RAV. G7441.200921	RAV. G7641.200945	RAV. G7641.200006	RAV. G7641.201041	RAV. G7641.200907	RAV. G7641.200689	RAV. G7641.201010	RAV. G7641.201089	RAV. G7641.200761	RAV. G7645.201232	RAV. G7645.200914	RAV. G7645.200990	RAV. G8645.201249	SFA. GA441.200976	SFA. GA441.201126	SFA. GA441.202000	SFA. GAG41.201027	SFA. GAG41.201096	SFA. GAG41.200952	SFA. GAG41.201058	SFA. GAG45.200600		
		●					●					●					●									●							●				●				
#		D.R	N	Descrizione	Description	Beschreibung	Description	Descripción																																	

1	✓		203019	TE M6x16	TE M6x16 bolt	Schraube TE M6x16	Vis TE M6x16	Tornillo TE M6x16				
2	✓		238004	Rondella elastica 6,4	6.4 spring washer	Elastische Unterlagsscheibe 6,4	Rondelle elastique 6,4	Arandela elástica 6,4				
3	✓		224007	Dado medio M6	M6 med nut	Mittlere Mutter M6	Écrou moyen M6	Tuerca media M6				
4	✓		790010121	Serbatoio	Tank	Tank	Réservoir	Tanque				
5	✓		B1202700	Raccordo nippo M-M1"	M-M1" nipple fitting	Nippelanschluss M-M1"	Raccord mamelon M-M1"	Empalme niple M-M1"				
6	✓		309095	Valvola di soffiaggio	Blow valve	Blasventil	Soupage de souflage	Válvula di soplado				
7	✓		533016	Riduzione	Reduction	Reduzierstück	Réduction	Reducción				
8	✓		325031	Raccordo girevole	Rotating fitting	Drehanschluss	Raccord pivotant	Empalme giratorio				
9	✓		B1175900	Rubinetto scarico 1/2"	1/2" Release cock	Ablaufventil 1/2"	Robinet décharge 1/2"	Llave descarga 1/2"				
10	✓		730016760	Raccordo a Y	Y-shaped fitting	Y-Anschluss	Raccord à Y	Empalme en Y				
11	✓		B1146000	Raccordo T 1/4" MFF	1/4" MFF T-fitting	T-Anschluss 1/4" MWW	Raccord T 1/4" MFF	Empalme T 1/4" MHH				
12	✓		B1505000	Valvola di sicurezza	Safety valve	Sicherheitsventil	Soupage de sécurité	Válvula de seguridad				

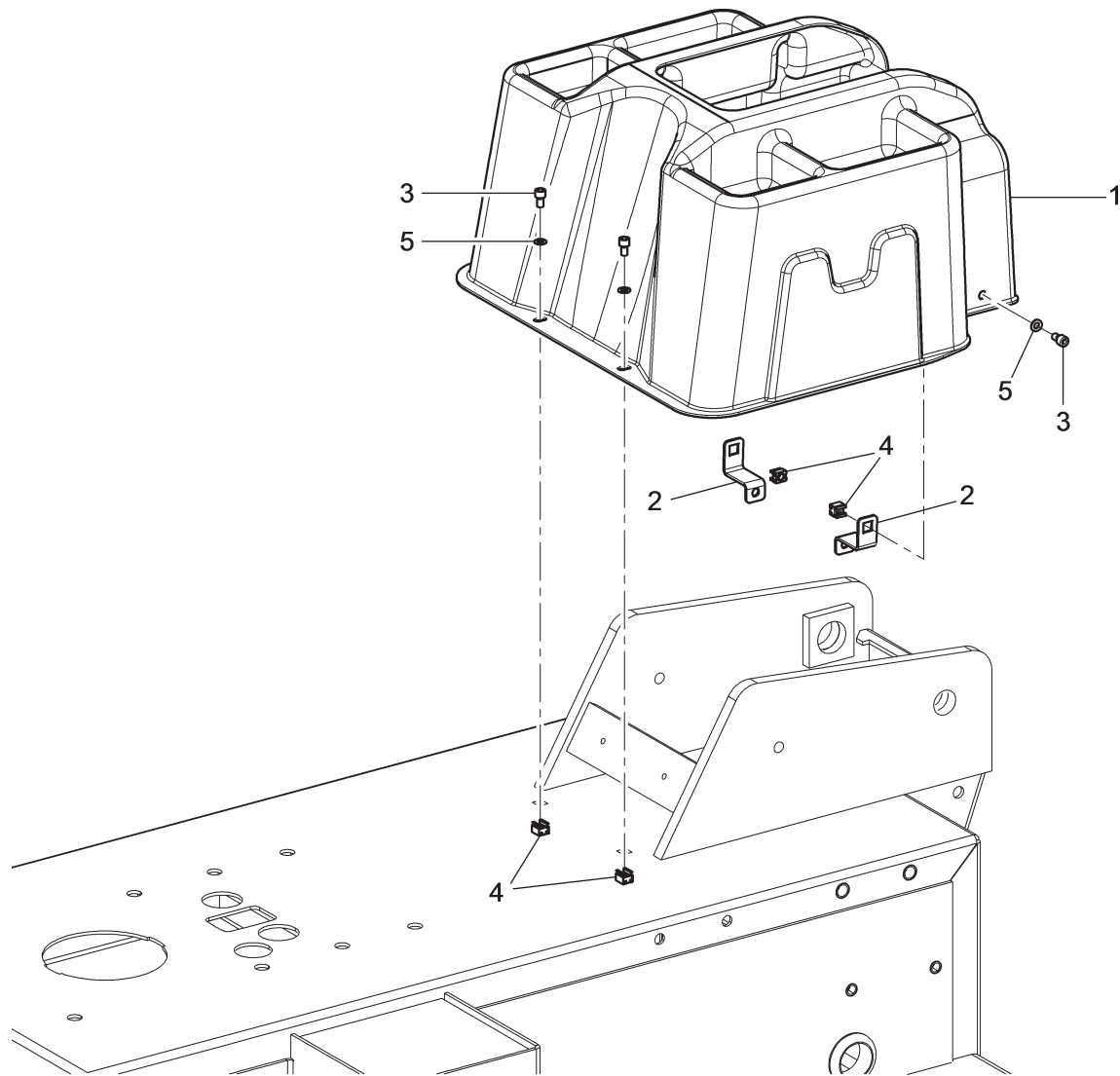

•	ROT. HP441.201102	ROT. HP641.200838	ROT. HF641.201034	ROT. HP641.200891	ROT. HF641.200785	ROT.HP641.201003	ROT.HP641.201788	ROT. HP641.201072	ROT. HP641.201065	ROT. HP641.201897	ROT.HP643.200684	ROT.HP643.201881	ROT. HP643.201133	ROT. HF643.200983	RAV. G7441.201140	RAV. G7441.200969	RAV. G7441.201119	RAV. G7441.200716	RAV. G7441.200877	RAV. G7441.200821	RAV. G7641.200945	RAV. G7641.200006	RAV. G7641.201041	RAV.G7641.200907	RAV.G7641.200683	RAV. G7641.201010	RAV. G7641.201089	RAV. G7641.200761	RAV. G7645.201232	RAV. G7645.200914	RAV. G7645.200990	RAV. G8645.201249	SFA. GA441.200976	SFA. GA441.201126	SFA. GA441.202000	SFA. GA641.201027	SFA. GA641.201096	SFA. GA641.200952	SFA. GA641.201058	SFA. GA645.200600
---	----------------------	----------------------	----------------------	----------------------	----------------------	------------------	------------------	----------------------	----------------------	----------------------	------------------	------------------	----------------------	----------------------	----------------------	----------------------	----------------------	----------------------	----------------------	----------------------	----------------------	----------------------	----------------------	------------------	------------------	----------------------	----------------------	----------------------	----------------------	----------------------	----------------------	----------------------	----------------------	----------------------	----------------------	----------------------	----------------------	----------------------	----------------------	----------------------



**LISTA DEI COMPONENTI - LIST OF COMPONENTS - TEILELISTE  
LISTE DES PIÈCES DÉTACHÉES - LISTA DE PIEZAS**

**Tavola N°21A - Rev. 0**

**140390790**

KIT SERBATOIO  
TANK KIT  
TANKSET  
KIT RÉSERVOIR  
KIT TANQUE



**Pag. 159 di 235**



LISTA DEI COMPONENTI - LIST OF COMPONENTS - TEILELISTE  
LISTE DES PIECES DETACHEES - LISTA DE PIEZAS

KIT SERBATOIO  
TANK KIT  
TANKSET  
KIT RÉSERVOIR  
KIT TANQUE

Tavola N°21A - Rev. 0

140390790

ROT. HP441.201102	ROT. HP641.200938	ROT. HP641.201034	ROT. HP641.200891	ROT. HP641.200785	ROT.HP641.201003	ROT.HP641.201788	ROT. HP641.201072	ROT. HP641.201065	ROT. HP641.201997	ROT.HP643.200984	ROT.HP643.201681	ROT. HP643.201133	ROT. HP643.200983	RAV G7441.201140	RAV G7441.200969	RAV G7441.201119	RAV G7441.200716	RAV G7441.200877	RAV G7441.200921	RAV G7641.200945	RAV G7641.200006	RAV G7641.201041	RAV.G7641.200907	RAV.G7641.200689	RAV G7641.201010	RAV G7641.201089	RAV G7641.200761	RAV G7645.201232	RAV G7645.200914	RAV G7645.200990	RAV G8645.201249	SFA GA441.200976	SFA GA441.201126	SFA GA441.202000	SFA GA641.201027	SFA GA641.201096	SFA GA641.200952	SFA GA641.201058	SFA GA645.200600				
●																																											
#		D.R	N	Descrizione	Description	Beschreibung	Description	Descripción	▶		▶																																

1	✓		B4114300	Copertura base palo	Post base cover	Stangenbodenabdeckung	Couverture embase poteau	Cobertura base palo		
2	✓		B4114400	Lamiera attacco carter	Guard coupling plate	Gehäusenanschlussblech	Tôle branchement carter	Chapa conexión cárter		
3	✓		206012	TCEI M6x10	TCEI M6x10 bolt	Schraube TCEI M6x10	Vis TCEI M6x10	Tornillo TCEI M6x10		
4	✓		228250	Dado in gabbia M6	M6 caged nut	Mutter im Käfig M6	Écrou en cage M6	Tuerca en jaula M6		
5	✓		236004	Rondella piana 6,4	6.4 flat washer	Ebene Unterlagsscheibe 6,4	Rondelle plane 6,4	Arandela plana 6,4		

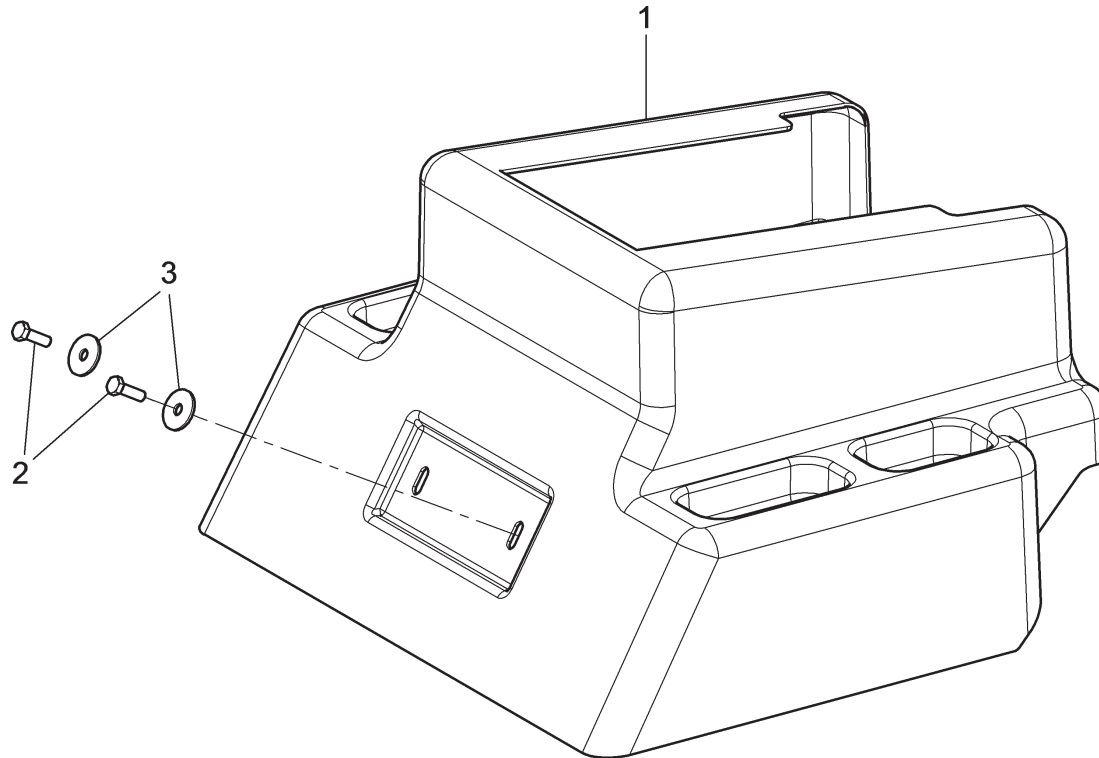

ROT. HP441.201102	•	ROT. HP641.200838	•	ROT. HF641.201034	•	ROT. HP641.200891	•	ROT. HP641.200785	•	ROT:HP641.201063 ROT:HP641.201788	•	ROT. HP641.201072	•	ROT. HP641.201065	•	ROT. HP641.201897	•	ROT:HP643.200884 ROT:HP643.201881	•	ROT. HP643.201133	•	ROT. HP643.200983	•	RAV. G7441.201140		RAV. G7441.200969		RAV. G7441.201119		RAV. G7441.200716		RAV. G7441.200877		RAV. G7441.200821		RAV. G7641.200945		RAV. G7641.200006		RAV. G7641.201041		RAV:G7641.200907 RAV:G7641.200683		RAV. G7641.201010		RAV. G7641.201089		RAV. G7641.200761		RAV. G7645.201232	•	RAV. G7645.200914	•	RAV. G7645.200990	•	RAV. G8645.201249	•	SFA. GA441.200976		SPA. GA441.201126		SFA. GA441.202000		SFA. GA641.201027		SFA. GA641.201096		SFA. GA641.200952		SFA. GA641.201058		SFA. GA645.200600	•
		<b>LISTA DEI COMPONENTI - LIST OF COMPONENTS - TEILELISTE</b> <b>LISTE DES PIÈCES DÉTACHÉES - LISTA DE PIEZAS</b>																								COPERTURA BASE PALO POST BASE COVER STANGENBODENABDECKUNG COUVERTURE EMBASE POTEAU COBERTURA BASE PALO												▶																																			
		<b>Tavola N°21B - Rev. 0</b>												<b>730097520</b>												<b>Pag. 161 di 235</b>																																															



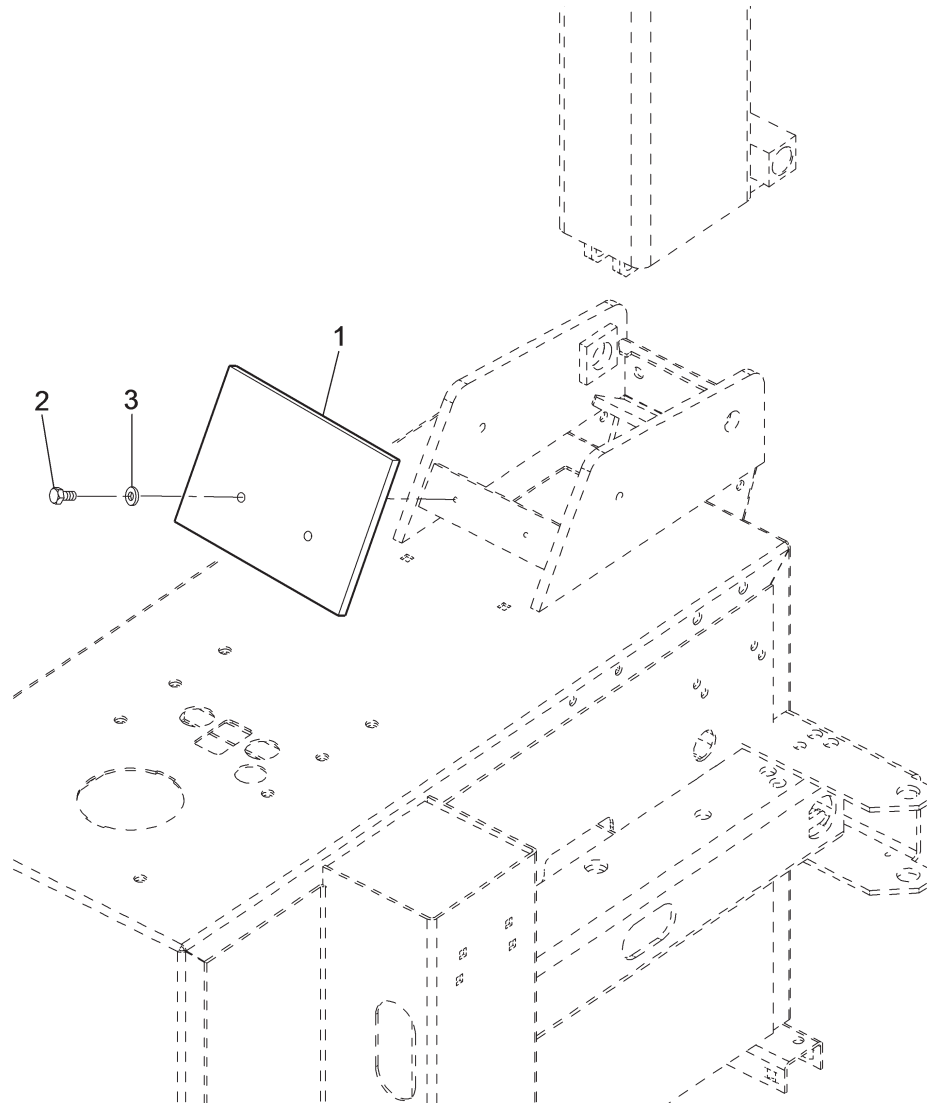

ROT.	HP441.201102	
ROT.	HP641.200838	
ROT.	HF641.201034	
ROT.	HP641.200891	
ROT.	HP641.200785	
ROT.	HP641.201063	
ROT.	HP641.201788	
ROT.	HP641.201072	
ROT.	HP641.201065	
ROT.	HP641.201897	
ROT.	HP643.200884	
ROT.	HP643.201881	
ROT.	HP643.201133	
ROT.	HP643.200983	
RAV.	G7441.201140	•
RAV.	G7441.200969	•
RAV.	G7441.201119	•
RAV.	G7441.200716	•
RAV.	G7441.200877	•
RAV.	G7441.200821	•
RAV.	G7641.200945	
RAV.	G7641.200006	
RAV.	G7641.201041	
RAV.	G7641.200907	
RAV.	G7641.200683	
RAV.	G7641.201010	
RAV.	G7641.201089	
RAV.	G7641.200761	
RAV.	G7645.201232	
RAV.	G7645.200914	
RAV.	G7645.200890	
RAV.	G8645.201249	
SFA.	GA441.200976	•
SFA.	GA441.201126	•
SFA.	GA441.202000	•
SFA.	GA641.201027	
SFA.	GA641.201096	
SFA.	GA641.200952	
SFA.	GA641.201058	
SFA.	GA645.200600	



**LISTA DEI COMPONENTI - LIST OF COMPONENTS - TEILELISTE**  
**LISTE DES PIÈCES DÉTACHÉES - LISTA DE PIEZAS**

**Tavola N°22A - Rev. 0**

**140390580**

GRUPPO PROTEZIONE BASE PALO  
 POST BASE PROTECTION ASSEMBLY  
 STANGENBODEN-SCHUTZSATZ  
 ENSEMBLE PROTECTION EMBASE POTEAU  
 CONJUNTO PROTECCIÓN BASE PALO



**LISTA DEI COMPONENTI - LIST OF COMPONENTS - TEILELISTE  
LISTE DES PIÈCES DÉTACHÉES - LISTA DE PIEZAS**

GRUPPO PROTEZIONE BASE PALO  
POST BASE PROTECTION ASSEMBLY  
STANGENBODEN-SCHUTZSATZ  
ENSEMBLE PROTECTION EMBASE POTEAU  
CONJUNTO PROTECCIÓN BASE PALO

**Tavola N°22A - Rev. 0**

**140390580**

ROT. HP641.201102	ROT. HP641.200938	ROT. HP641.201034	ROT. HP641.200891	ROT. HP641.200785	ROT. HP641.201003	ROT. HP641.201788	ROT. HP641.201072	ROT. HP641.201065	ROT. HP641.201997	ROT. HP643.200984	ROT. HP643.201681	ROT. HP643.201133	ROT. HP643.200983	RAV. G7441.201140	RAV. G7441.200969	RAV. G7441.201119	RAV. G7441.200716	RAV. G7441.200877	RAV. G7441.200921	RAV. G7641.200945	RAV. G7641.200006	RAV. G7641.201041	RAV. G7641.200907	RAV. G7641.200689	RAV. G7641.201010	RAV. G7641.201089	RAV. G7641.200761	RAV. G7645.201232	RAV. G7645.200914	RAV. G7645.200990	RAV. G8645.201249	SFA. GA441.200976	SFA. GA441.201126	SFA. GA441.202000	SFA. GA641.201027	SFA. GA641.201096	SFA. GA641.200952	SFA. GA641.201058	SFA. GA645.200600							
<b>#</b>		<b>D.R</b>	<b>N</b>	<b>Descrizione</b>	<b>Description</b>	<b>Beschreibung</b>	<b>Description</b>	<b>Descripción</b>																																						

1	✓		140301920	Copertura base palo	Post base cover	Stangenbodenabdeckung	Couverture embase poteau	Cobertura base palo		
2	✓		203146	TE M5x16	TE M5x6 bolt	Schraube TE M5x16	Vis TE M5x16	Tornillo TE M5x16		
3	✓		237010	Rondella piana 5,5x20x1,5	5x20x1.5 washer	Ebene Unterlagsscheibe 5x20x1,5	Rondelle 5x20x1,5	Arandela 5x20x1,5		

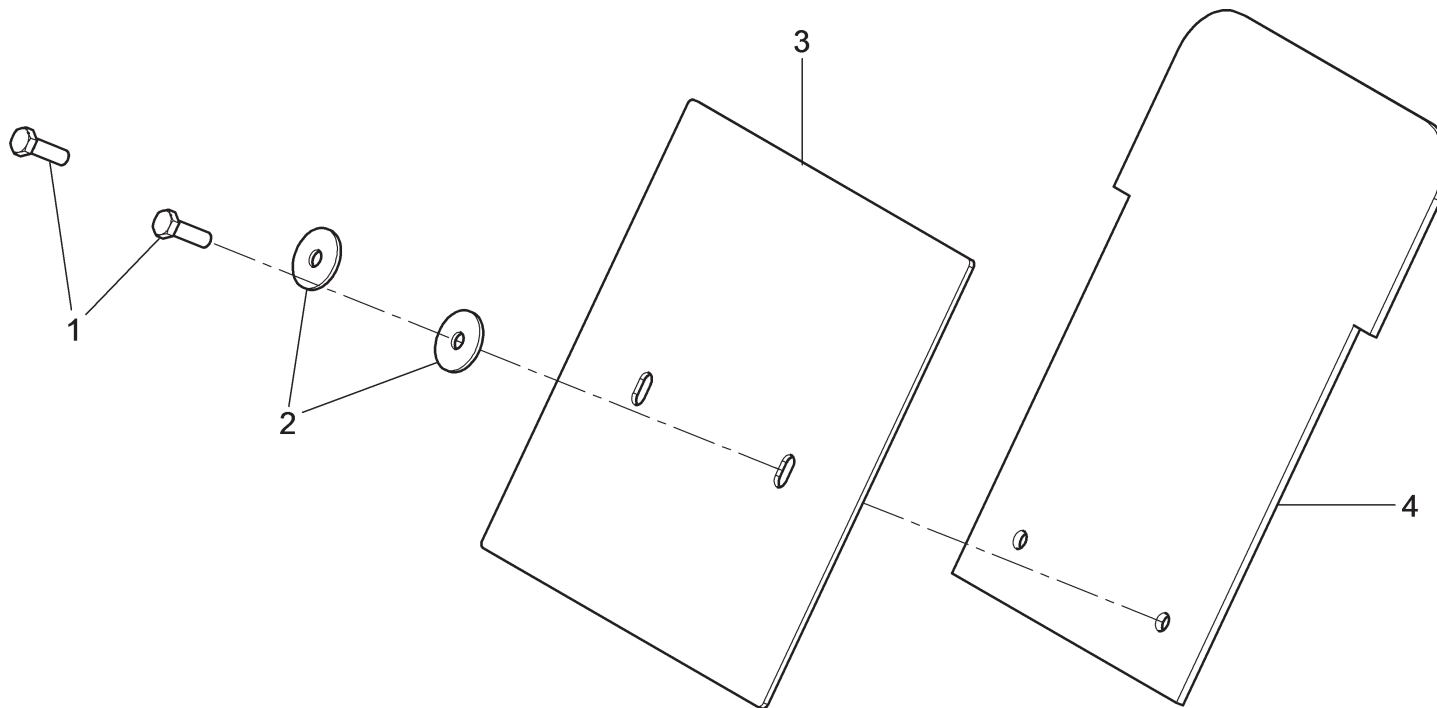

ROT. HP441.201102	ROT. HP641.200838	ROT. HF641.201034	ROT. HP641.200891	ROT. HF641.200785	ROT.HF641.201063 ROT.HF641.201788	ROT. HP641.201072	ROT. HP641.201065	ROT. HP641.201897	ROT.HF643.200894 ROT.HF643.201881	ROT. HP643.201133	ROT. HF643.200983	RAV. G7441.201140	RAV. G7441.200969	RAV. G7441.201119	RAV. G7441.200716	RAV. G7441.200877	RAV. G7441.200821	RAV. G7641.200945	RAV. G7641.200006	RAV. G7641.201041	RAV.G7641.200907 RAV.G7641.200683	RAV. G7641.201010	RAV. G7641.201089	RAV. G7641.200761	RAV. G7645.201232	RAV. G7645.200914	RAV. G7645.200990	RAV. G8645.201249	SFA. GA441.200976	SPA. GA441.201126	SFA. GA441.202000	SPA. GA641.201027	SFA. GA641.201096	SPA. GA641.200952	SPA. GA641.201058	SPA. GA645.200600	
																		•	•	•	•	•	•									•	•	•	•		
		<b>LISTA DEI COMPONENTI - LIST OF COMPONENTS - TEILELISTE</b> <b>LISTE DES PIÈCES DÉTACHÉES - LISTA DE PIEZAS</b>																			COPERTURA PALO POST COVER STANGENABDECKUNG COUVERTURE POTEAU COBERTURA PALO																
		<b>Tavola N°22B - Rev. 0</b>									<b>730098200</b>									<b>Pag. 165 di 235</b>																	



LISTA DEI COMPONENTI - LIST OF COMPONENTS - TEILELISTE  
LISTE DES PIÈCES DÉTACHÉES - LISTA DE PIEZAS

COPERTURA PALO  
POST COVER  
STANGENABDECKUNG  
COUVERTURE POTEAU  
COBERTURA PALO

Tavola N°22B - Rev. 0

730098200

#		D.R	N	Descrizione	Description	Beschreibung	Description	Descripción		
1	✓		203146	TE M5x16	TE M5x6 bolt	Schraube TE M5x16	Vis TE M5x16	Tornillo TE M5x16		
2	✓		237010	Rondella piana 5,5x20x1,5	5x20x1.5 washer	Ebene Unterlagsscheibe 5x20x1,5	Rondelle 5x20x1,5	Arandela 5x20x1,5		
3	✓		730029590	Carter anteriore	Front guard	Vorderes Gehäuse	Carter antérieur	Cárter anterior		
4	✓		730029580	Protezione	Guard	Gehäuse	Protection	Protección		

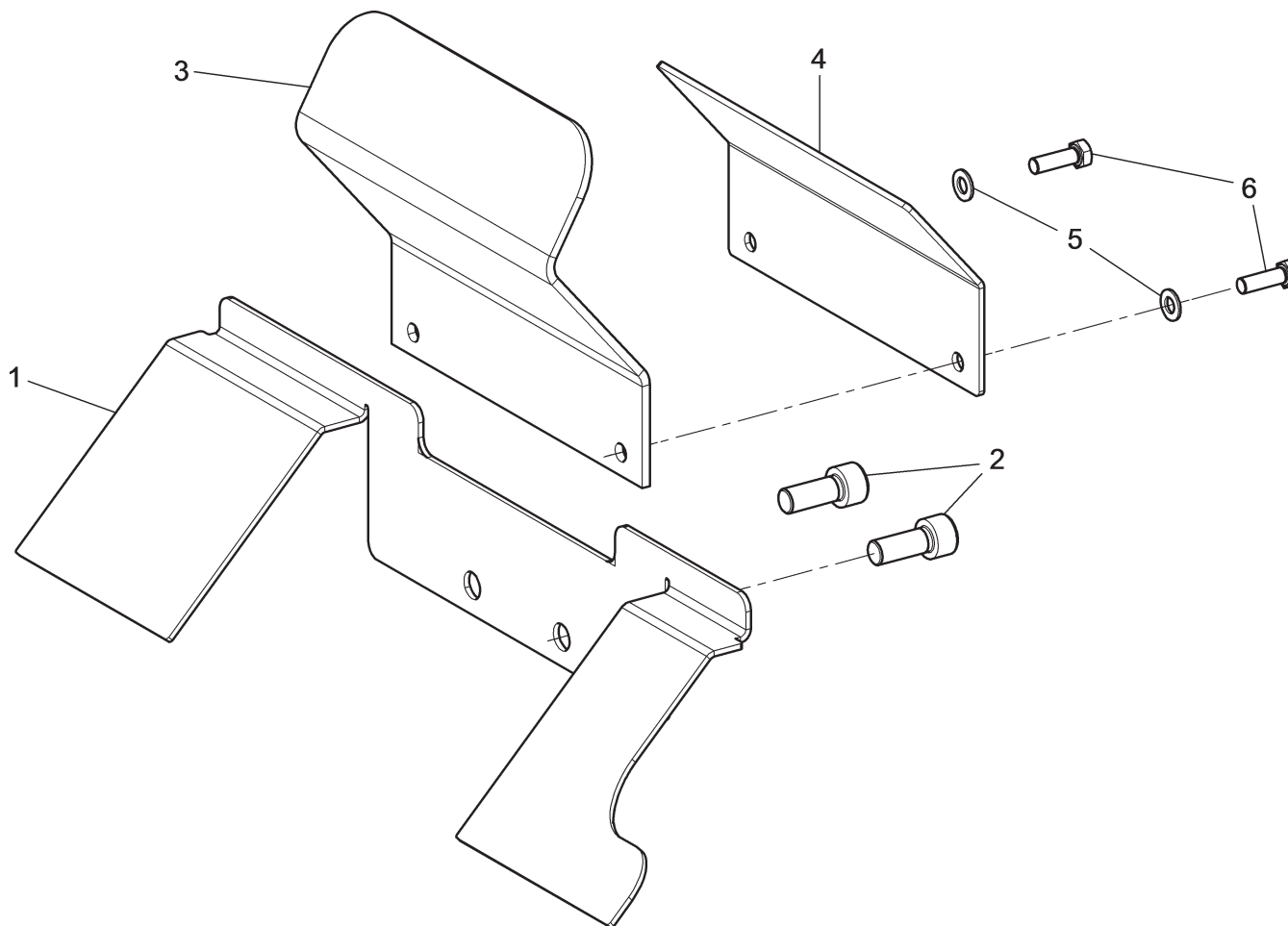

ROT. HP441.201102	•	ROT. HP641.200838	•	ROT. HF641.201034	•	ROT. HP641.200891	•	ROT. HP641.200785	•	ROT.HP641.201063 ROT.HP641.201788	•	ROT. HP641.201072	•	ROT. HP641.201065	•	ROT. HP641.201897	•	ROT.HP643.200884 ROT.HP643.201881	•	ROT. HP643.201133	•	ROT. HP643.200983	•	RAV. G7441.201140		RAV. G7441.200969		RAV. G7441.201119		RAV. G7441.200716		RAV. G7441.200877		RAV. G7441.200821		RAV. G7641.200945		RAV. G7641.200006		RAV. G7641.201041		RAV.G7641.200907 RAV.G7641.200683		RAV. G7641.201010		RAV. G7641.201089		RAV. G7641.200761		RAV. G7645.201232	•	RAV. G7645.200914	•	RAV. G7645.200890	•	RAV. G8645.201249	•	SFA. GA441.200976		SPA. GA441.201126		SFA. GA441.202000		SPA. GA641.201027		SPA. GA641.201096		SPA. GA641.200952		SPA. GA641.201058		SPA. GA645.200600	•
		<b>LISTA DEI COMPONENTI - LIST OF COMPONENTS - TEILELISTE</b> <b>LISTE DES PIÈCES DÉTACHÉES - LISTA DE PIEZAS</b>																								COPERTURA BASE PALO POST BASE COVER STANGENBODENABDECKUNG COUVERTURE EMBASE POTEAU COBERTURA BASE PALO												▶																																			
		<b>Tavola N°23A - Rev. 0</b>												<b>730097530</b>												<b>Pag. 167 di 235</b>																																															



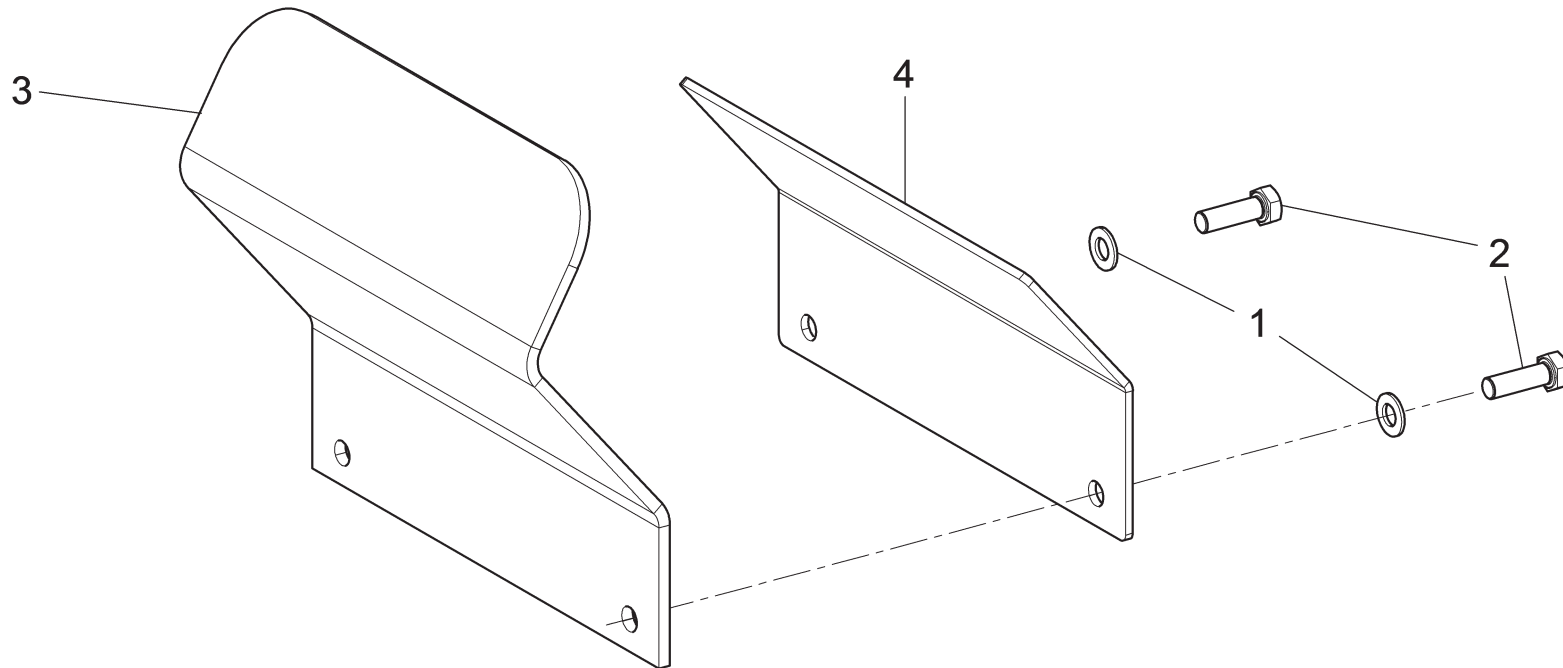

ROT. HP441.201102	ROT. HP641.200838	ROT. HF641.201034	ROT. HP641.200891	ROT. HP641.200785	ROT.HP641.201063 ROT.HP641.201788	ROT. HP641.201072	ROT. HP641.201065	ROT. HP641.201897	ROT.HP643.200884 ROT.HP643.201881	ROT. HP643.201133	ROT. HF643.200983	RAV. G7441.201140	RAV. G7441.200969	RAV. G7441.201119	RAV. G7441.200716	RAV. G7441.200877	RAV. G7441.200821	RAV. G7641.200945	RAV. G7641.200006	RAV. G7641.201041	RAV.G7641.200907 RAV.G7641.200683	RAV. G7641.201010	RAV. G7641.201089	RAV. G7641.200761	RAV. G7645.201232	RAV. G7645.200914	RAV. G7645.200890	RAV. G8645.201249	SFA. GA441.200876	SPA. GA441.201126	SFA. GA441.202000	SPA. GA641.201027	SPA. GA641.201096	SPA. GA641.200952	SPA. GA641.201058	SPA. GA645.200600	
																		•	•	•	•	•	•										•	•	•	•	
		<b>LISTA DEI COMPONENTI - LIST OF COMPONENTS - TEILELISTE</b> <b>LISTE DES PIÈCES DÉTACHÉES - LISTA DE PIEZAS</b>																			KIT COPERTURA BASE PALO POST BASE COVER KIT STANGENBODENABDECKUNGSSET KIT COUVERTURE EMBASE POTEAU KIT COBERTURA BASE PALO																
		<b>Tavola N°23B - Rev. 0</b>											<b>730099860</b>								<b>Pag. 169 di 235</b>																

**Tavola N°23B - Rev. 0**

**730099860**

ROT. HP641.201102	ROT. HP641.200938	ROT. HP641.201034	ROT. HP641.200891	ROT. HP641.200785	ROT.HP641.201003	ROT.HP641.201788	ROT. HP641.201072	ROT. HP641.201065	ROT. HP641.201997	ROT.HP643.200984	ROT.HP643.201681	ROT. HP643.201133	ROT. HP643.200983	RAV G7441.201140	RAV G7441.200969	RAV G7441.201119	RAV. G7441.200716	RAV. G7441.200877	RAV G7441.200921	RAV G7641.200945	RAV G7641.200006	RAV G7641.201041	RAV.G7641.200907	RAV.G7641.200689	RAV. G7641.201010	RAV. G7641.201089	RAV. G7641.200761	RAV G7645.201232	RAV G7645.200914	RAV G7645.200990	RAV G8645.201249	SFA GA441.200976	SFA GA441.201126	SFA GA441.202000	SFA GA641.201027	SFA GA641.201096	SFA GA641.200952	SFA GA641.201058	SFA GA645.200600					

#		D.R	N	Descrizione	Description	Beschreibung	Description	Descripción	→	→
1	✓		236026	Rondella 5,3	5.3 washer	Untertagsscheibe 5,3	Rondelle 5,3	Arandela 5,3		
2	✓		203146	TE M5x16	TE M5x6 bolt	Schraube TE M5x16	Vis TE M5x16	Tornillo TE M5x16		
3	✓		730012360	Protezione	Guard	Gehäuse	Protection	Protección		
4	✓		730012380	Carter	Guard	Gehäuse	Carter	Cárter		





LISTA DEI COMPONENTI - LIST OF COMPONENTS - TEILELISTE  
 LISTE DES PIÈCES DÉTACHÉES - LISTA DE PIEZAS

COPERTURA BRACCIO  
 ARM COVER  
 ARMABDECKUNG  
 COUVERTURE BRAS  
 COBERTURA BRAZO

Tavola N°24A - Rev. 0

730097730

#	D.R	N	Descrizione	Description	Beschreibung	Description	Descripción	→	→
1	✓	730021521	Copertura anteriore	Front cover	Vordere Abdeckung	Couverture antérieure	Cobertura anterior		
2	✓	220063	TCB M4,2x13	TCB M4.2x13 bolt	Schraube M4,2x13	Vis M4,2x13	Tornillo M4,2x13		
3	✓	236025	Rosetta d. 4,3x9x0,8	D. 4.3x9x0.8 washer	Unterlegscheibe d. 4,3x9x0,8	Rondelle d. 4,3x9x0,8	Arandela d. 4,3x9x0,8		

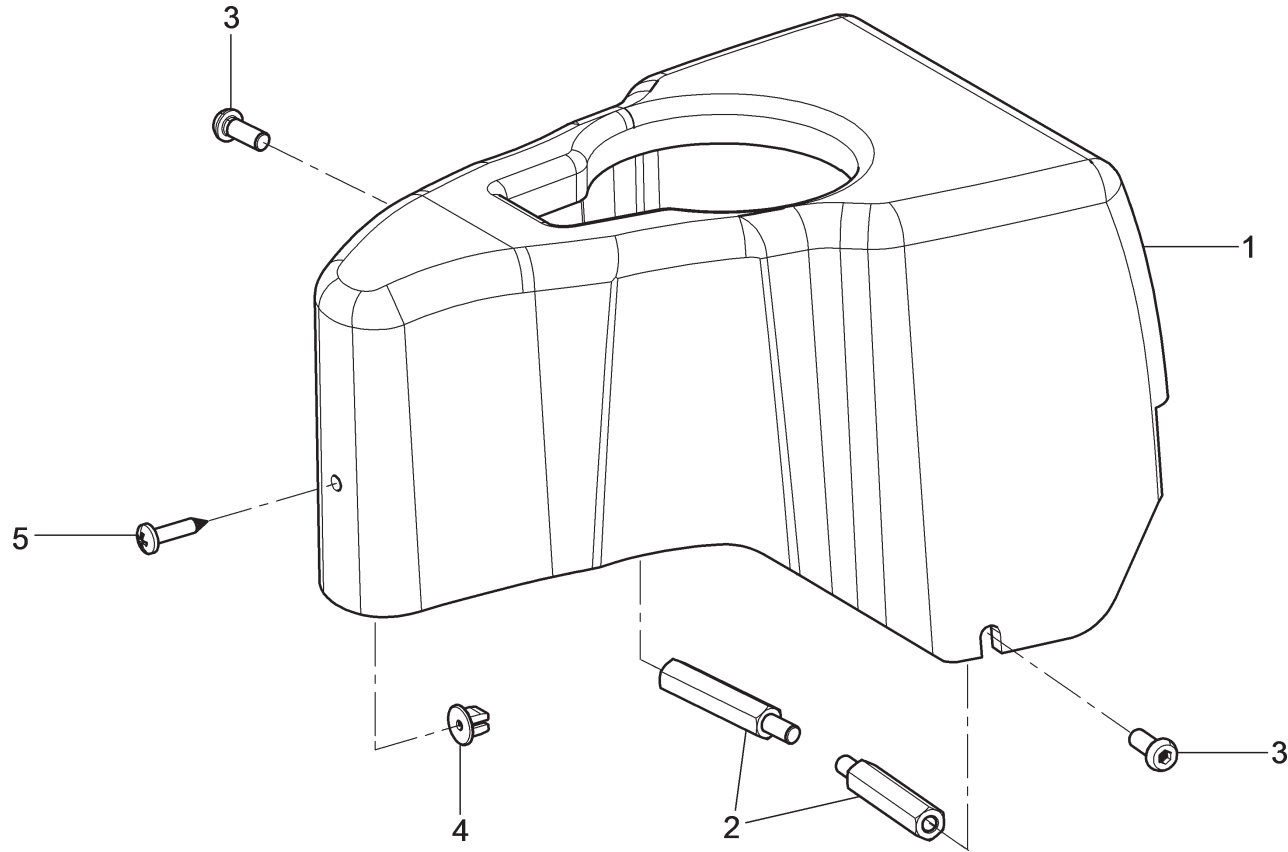

ROT. HP441.201102	ROT. HP641.200838	ROT. HF641.201034	ROT. HP641.200891	ROT. HF641.200785	ROT.HP641.201063 ROT.HP641.201788	ROT. HP641.201072	•	ROT. HF641.201065	ROT. HP641.201897	ROT.HP643.200884 ROT.HP643.201881	ROT. HP643.201133	ROT. HF643.200983	RAV. G7441.201140	RAV. G7441.200969	RAV. G7441.201119	RAV. G7441.200716	RAV. G7441.200877	RAV. G7441.200821	RAV. G7641.200945	RAV. G7641.200006	RAV. G7641.201041	RAV.G7641.200907 RAV.G7641.200683	RAV. G7641.201010	RAV. G7641.201089	RAV. G7641.200761	RAV. G7645.201232	RAV. G7645.200914	RAV. G7645.200990	RAV. G8645.201249	SFA. GA441.200976	SPA. GA441.201126	SFA. GA441.202000	SPA. GA641.201027	SPA. GA641.201096	SPA. GA641.200952	SPA. GA641.201058	SPA. GA645.200600				
																				<b>LISTA DEI COMPONENTI - LIST OF COMPONENTS - TEILELISTE</b> <b>LISTE DES PIÈCES DÉTACHÉES - LISTA DE PIEZAS</b>										COPERTURA BRACCIO ARM COVER ARMABDECKUNG COUVERTURE BRAS COBERTURA BRAZO											
Tavola N°24B - Rev. 0										730098280										<b>Pag. 173 di 235</b>																					



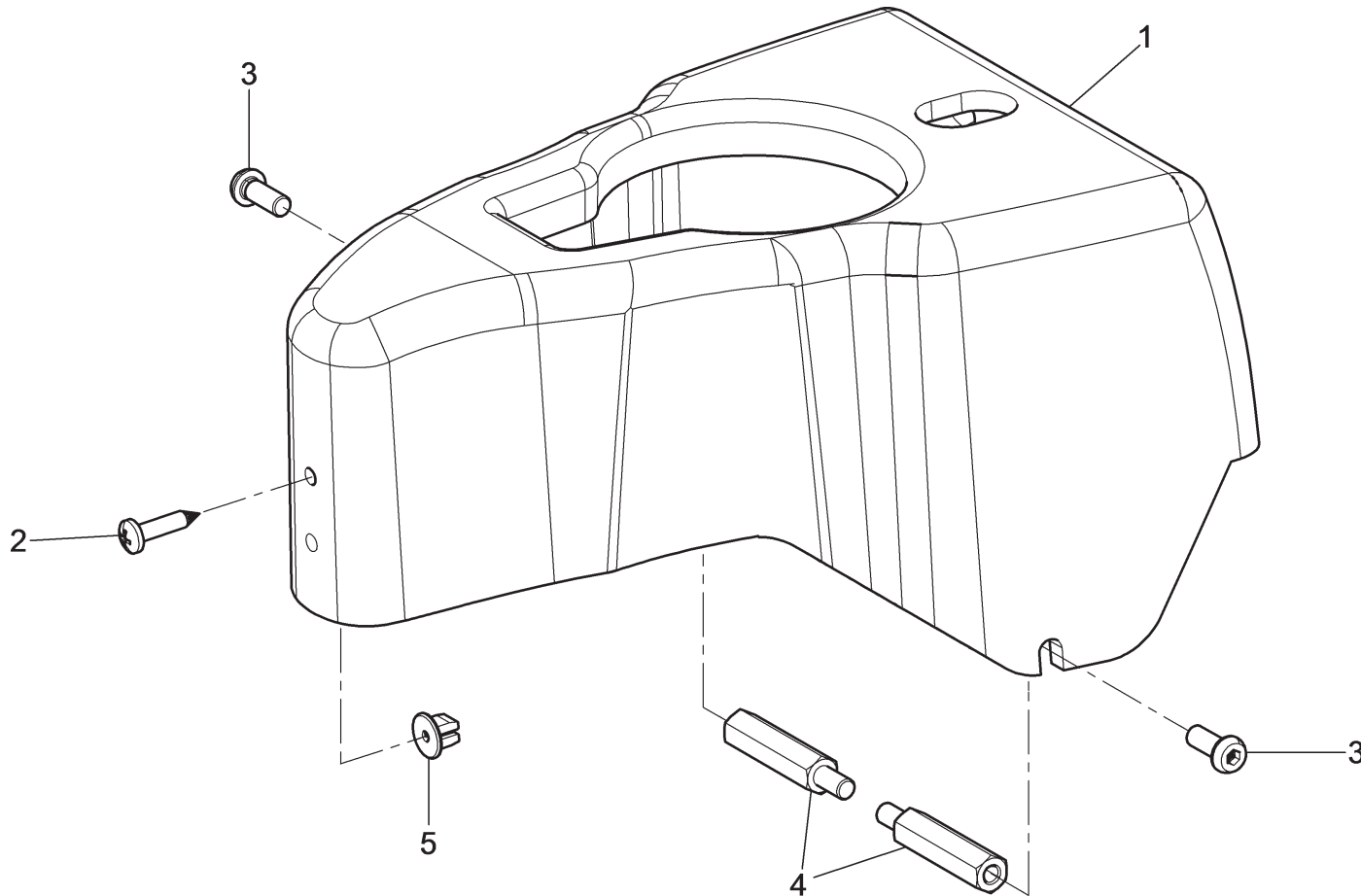

ROT. HP441.201102	ROT. HP641.200838	ROT. HF641.201034	ROT. HP641.200891	ROT. HF641.200785	ROT. HP641.201063	ROT. HP641.201788	ROT. HP641.201072	ROT. HF641.201065	ROT. HP641.201897	ROT. HF643.200894	ROT. HP643.201881	ROT. HP643.201133	ROT. HF643.200983	RAV. G7441.201140	RAV. G7441.200969	RAV. G7441.201119	RAV. G7441.200716	RAV. G7441.200877	RAV. G7441.200821	RAV. G7641.200945	RAV. G7641.200006	RAV. G7641.201041	RAV. G7641.200907	RAV. G7641.200683	RAV. G7641.201010	RAV. G7641.201089	RAV. G7641.200761	RAV. G7645.201232	RAV. G7645.200914	RAV. G7645.200990	RAV. G8645.201249	SFA. GA441.200976	SPA. GA441.201126	SFA. GA441.202000	SPA. GA641.201027	SPA. GA641.201096	SPA. GA641.200952	SPA. GA641.201058	SPA. GA645.200600
●																																							
<b>LISTA DEI COMPONENTI - LIST OF COMPONENTS - TEILELISTE</b> <b>LISTE DES PIÈCES DÉTACHÉES - LISTA DE PIEZAS</b>																			COPERTURA BRACCIO ARM COVER ARMABDECKUNG COUVERTURE BRAS COBERTURA BRAZO						▶														
<b>Tavola N°24C - Rev. 0</b>																			<b>730097550</b>						▶														
																									<b>Pag. 175 di 235</b>														



**LISTA DEI COMPONENTI - LIST OF COMPONENTS - TEILELISTE  
LISTE DES PIÈCES DÉTACHÉES - LISTA DE PIEZAS**

COPERTURA BRACCIO  
ARM COVER  
ARMABDECKUNG  
COUVERTURE BRAS  
COBERTURA BRAZO

**Tavola N°24C - Rev. 0**

**730097550**

ROT. HP441.201102	ROT. HP641.200938	ROT. HP641.201034	ROT. HP641.200891	ROT. HP641.200785	ROT.HP641.201003	ROT.HP641.201788	ROT. HP641.201072	ROT. HP641.201065	ROT. HP641.201997	ROT.HP643.200984	ROT.HP643.201681	ROT. HP643.201133	ROT. HP643.200983	RAV. G7441.201140	RAV. G7441.200969	RAV. G7441.201119	RAV. G7441.200716	RAV. G7441.200877	RAV. G7441.200921	RAV. G7641.200945	RAV. G7641.200006	RAV. G7641.201041	RAV.G7641.200907	RAV.G7641.200689	RAV. G7641.201010	RAV. G7641.201089	RAV. G7641.200761	RAV. G7645.201232	RAV. G7645.200914	RAV. G7645.200990	RAV. G8645.201249	SFA. GA441.200976	SFA. GA441.201126	SFA. GA441.202000	SFA. GA641.201027	SFA. GA641.201096	SFA. GA641.200952	SFA. GA641.201058	SFA. GA645.200600
----------------------	----------------------	----------------------	----------------------	----------------------	------------------	------------------	----------------------	----------------------	----------------------	------------------	------------------	----------------------	----------------------	----------------------	----------------------	----------------------	----------------------	----------------------	----------------------	----------------------	----------------------	----------------------	------------------	------------------	----------------------	----------------------	----------------------	----------------------	----------------------	----------------------	----------------------	----------------------	----------------------	----------------------	----------------------	----------------------	----------------------	----------------------	----------------------

#		D.R	N	Descrizione	Description	Beschreibung	Description	Descripción		
---	--	-----	---	-------------	-------------	--------------	-------------	-------------	--	--

1	✓		730026230	Carter anteriore	Front guard	Vorderes Gehäuse	Carter antérieur	Cárter anterior		
2	✓		220084	TCB 4,2x22	4.2x22 TCB bolt	Schraube TCB 4,2x22	Vis TCB4,2x22	Tornillo TCB 4,2x22		
3	✓		266019	TBEI M6x16	TBEI M6x16 bolt	Schraube TBEI M6x16	Vis TBEI M6x16	Tornillo TBEI M6x16		
4	✓		730015160	Distanziale	Spacer	Abstandsstück	Entretoise	Distanciador		
5	✓		B3163000	Madrevite	Nut bolt	Leitspindel	Mère vis	Tornillo madre		

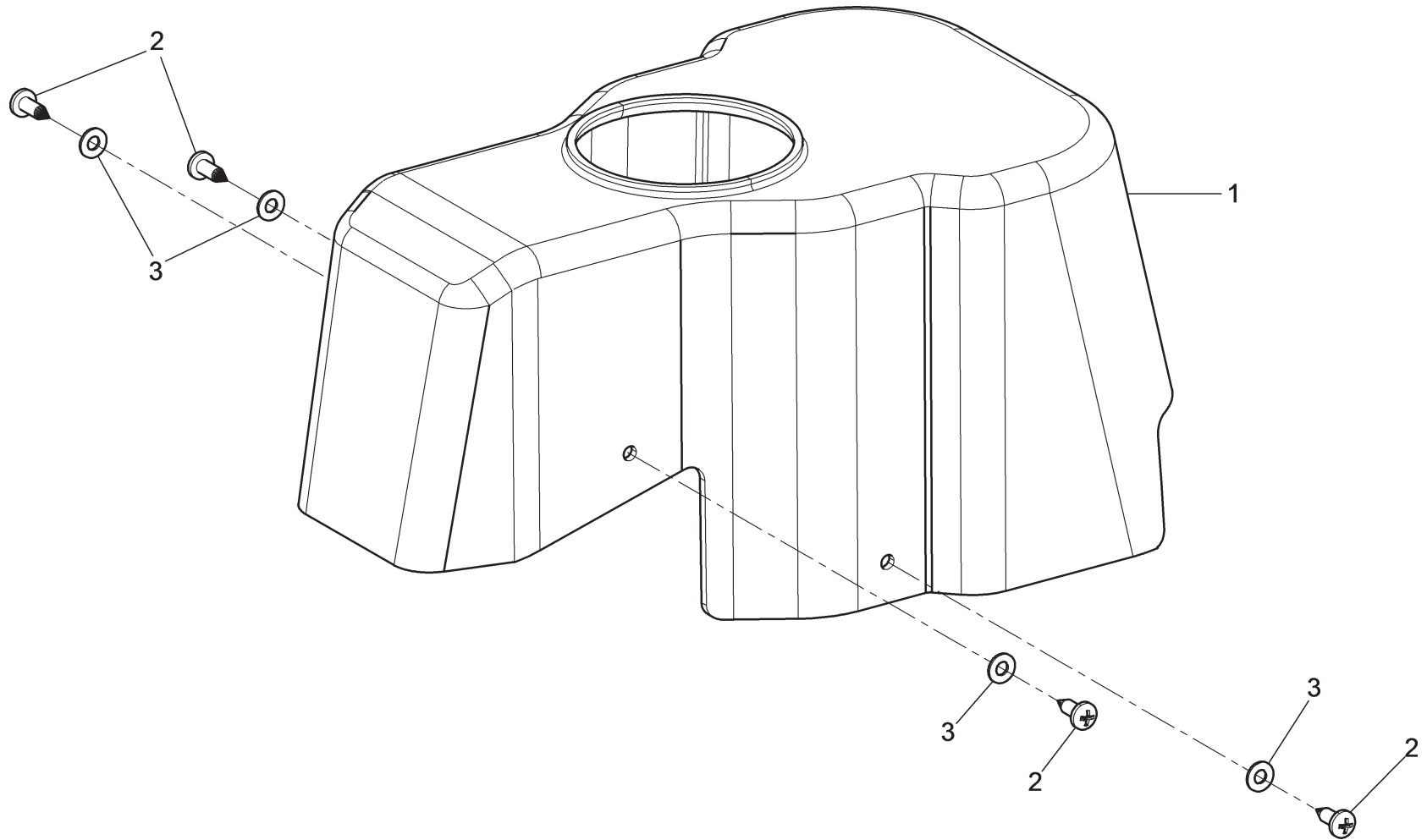



ROT. HP441.201102	ROT. HP641.200838	ROT. HF641.201034	ROT. HP641.200891	ROT. HF641.200785	ROT.HF641.201063 ROT.HF641.201788	ROT. HP641.201072	ROT. HF641.201065	ROT. HP641.201897	ROT.HF643.200884 ROT.HF643.201881	ROT. HP643.201133	ROT. HF643.200983	RAV. G7441.201140	RAV. G7441.200969	RAV. G7441.201119	RAV. G7441.200716	RAV. G7441.200877	RAV. G7441.200821	RAV. G7641.200945	RAV. G7641.200006	RAV. G7641.201041	RAV.G7641.200907 RAV.G7641.200683	RAV. G7641.201010	RAV. G7641.201089	RAV. G7641.200761	RAV. G7645.201232	RAV. G7645.200914	RAV. G7645.200990	RAV. G8645.201249	SFA. GA441.200976	SPA. GA441.201126	SFA. GA441.202000	SPA. GA641.201027	SFA. GA641.201096	SPA. GA641.200952	SPA. GA641.201058	SPA. GA645.200600				
												•	•	•	•	•	•	•	•	•	•	•	•	•	•	•	•	•	•	•	•	•	•	•	•	•	•	•	•	•
		<b>LISTA DEI COMPONENTI - LIST OF COMPONENTS - TEILELISTE</b> <b>LISTE DES PIÈCES DÉTACHÉES - LISTA DE PIEZAS</b>																			COPERTURA BRACCIO ARM COVER ARMABDECKUNG COUVERTURE BRAS COBERTURA BRAZO																			
		<b>Tavola N°24D - Rev. 0</b>		<b>730097820</b>		<b>Pag. 177 di 235</b>																																		

Tavola N°24D - Rev. 0

730097820

ROT. HP441.201102	ROT. HP641.200938	ROT. HP641.201034	ROT. HP641.200891	ROT. HP641.200785	ROT. HP641.201003	ROT. HP641.201788	ROT. HP641.201072	ROT. HP641.201065	ROT. HP641.201997	ROT. HP643.200984	ROT. HP643.201881	ROT. HP643.201133	ROT. HP643.200983	RAV G7441.201140	RAV G7441.200969	RAV G7441.201119	RAV G7441.200716	RAV G7441.200877	RAV G7441.200921	RAV G7641.200945	RAV G7641.200006	RAV G7641.201041	RAV G7641.200907	RAV G7641.200689	RAV G7641.201010	RAV G7641.201089	RAV G7641.200761	RAV G7645.201232	RAV G7645.200914	RAV G7645.200990	RAV G8645.201249	SFA GA441.200976	SFA GA441.201126	SFA GA441.202000	SFA GA641.201027	SFA GA641.201096	SFA GA641.200952	SFA GA641.201058	SFA GA645.200600
----------------------	----------------------	----------------------	----------------------	----------------------	----------------------	----------------------	----------------------	----------------------	----------------------	----------------------	----------------------	----------------------	----------------------	---------------------	---------------------	---------------------	---------------------	---------------------	---------------------	---------------------	---------------------	---------------------	---------------------	---------------------	---------------------	---------------------	---------------------	---------------------	---------------------	---------------------	---------------------	---------------------	---------------------	---------------------	---------------------	---------------------	---------------------	---------------------	---------------------

#	D.R	N	Descrizione	Description	Beschreibung	Description	Descripción		
---	-----	---	-------------	-------------	--------------	-------------	-------------	--	--

1	✓	730021540	Copertura anteriore	Front cover	Vordere Abdeckung	Couverture antérieure	Cobertura anterior		
2	✓	220063	TCB M4,2x13	TCB M4.2x13 bolt	Schraube M4,2x13	Vis M4,2x13	Tornillo M4,2x13		
3	✓	236025	Rosetta d. 4,3x9x0,8	D. 4.3x9x0.8 washer	Unterlegscheibe d. 4,3x9x0,8	Rondelle d. 4,3x9x0,8	Arandela d. 4,3x9x0,8		

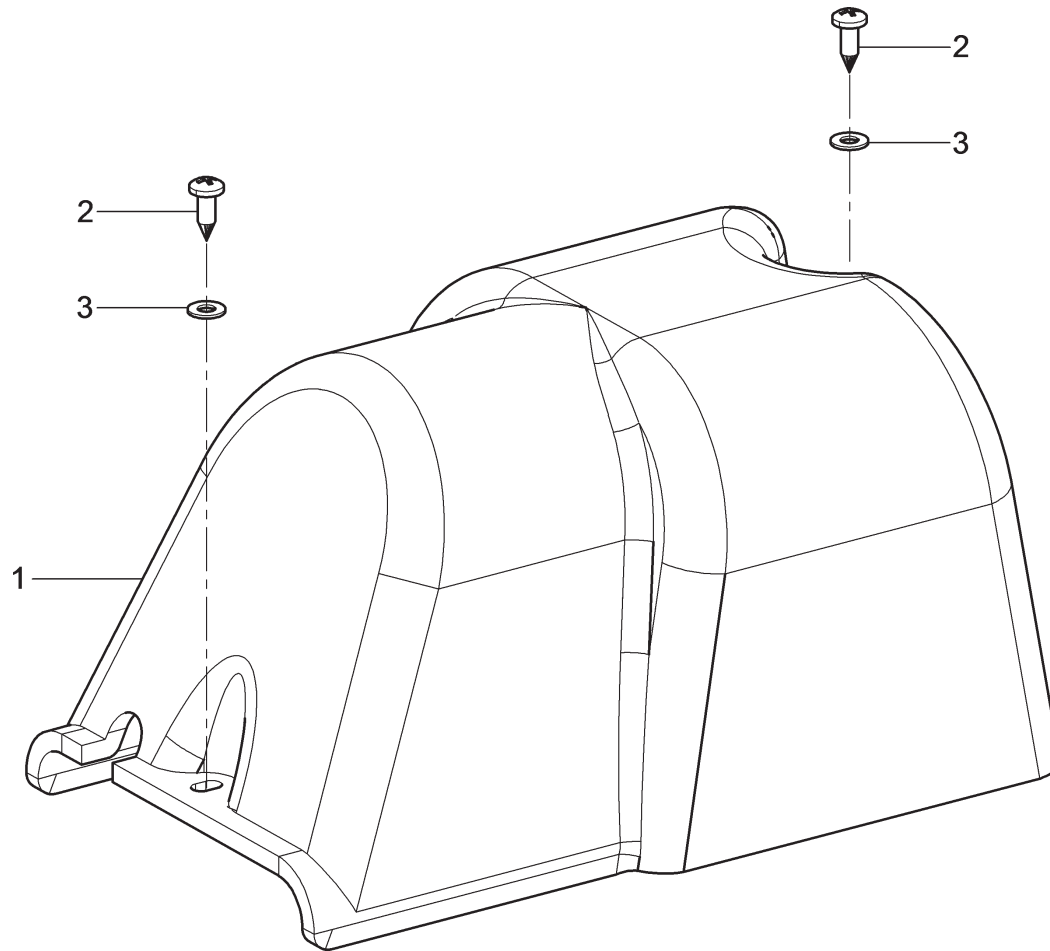

ROT. HP441.201102	ROT. HP641.200838	ROT. HF641.201034	ROT. HP641.200891	ROT. HF641.200785	ROT. HF641.201063	ROT. HF641.201788	ROT. HF641.201072	ROT. HF641.201065	ROT. HF641.201897	ROT. HP643.200894	ROT. HP643.201881	ROT. HP643.201133	ROT. HF643.200983	RAV. G7441.201140	RAV. G7441.200969	RAV. G7441.201119	RAV. G7441.200716	RAV. G7441.200877	RAV. G7441.200921	RAV. G7641.200945	RAV. G7641.200006	RAV. G7641.201041	RAV. G7641.200907	RAV. G7641.200683	RAV. G7641.201010	RAV. G7641.201089	RAV. G7641.200761	RAV. G7645.201232	RAV. G7645.200914	RAV. G7645.200990	RAV. G8645.201249	SFA. GA441.200976	SPA. GA441.201126	SFA. GA441.202000	SPA. GA641.201027	SPA. GA641.201096	SPA. GA641.200952	SPA. GA641.201058	SPA. GA645.200600			
•	•	•	•	•	•	•	•	•	•																																	



**LISTA DEI COMPONENTI - LIST OF COMPONENTS - TEILELISTE  
LISTE DES PIÈCES DÉTACHÉES - LISTA DE PIEZAS**

**Tavola N°25A - Rev. 0**

**730098130**

COPERTURA PALO  
POST COVER  
STANGENABDECKUNG  
COUVERTURE POTEAU  
COBERTURA PALO



LISTA DEI COMPONENTI - LIST OF COMPONENTS - TEILELISTE  
LISTE DES PIECES DETACHEES - LISTA DE PIEZAS

COPERTURA PALO  
POST COVER  
STANGENABDECKUNG  
COUVERTURE POTEAU  
COBERTURA PALO

Tavola N°25A - Rev. 0

730098130

ROT. HP441.201102	ROT. HP641.200938	ROT. HP641.201034	ROT. HP641.200891	ROT. HP641.200785	ROT. HP641.201003	ROT. HP641.201788	ROT. HP641.201072	ROT. HP641.201065	ROT. HP641.201997	ROT. HP643.200984	ROT. HP643.201681	ROT. HP643.201133	ROT. HP643.200983	RAV. G7441.201140	RAV. G7441.200969	RAV. G7441.201119	RAV. G7441.200716	RAV. G7441.200877	RAV. G7441.200921	RAV. G7641.200945	RAV. G7641.200006	RAV. G7641.201041	RAV. G7641.200907	RAV. G7641.200889	RAV. G7641.201010	RAV. G7641.201089	RAV. G7641.200761	RAV. G7645.201232	RAV. G7645.200914	RAV. G7645.200990	RAV. G8645.201249	SFA. GA441.200976	SFA. GA441.201126	SFA. GA441.202000	SFA. GA641.201027	SFA. GA641.201096	SFA. GA641.200952	SFA. GA641.201058	SFA. GA645.200600		
●	●	●	●	●	●	●	●	●	●																																
#		D.R	N	Descrizione	Description	Beschreibung	Description	Descripción																																	

1	✓		B4114200	Carter	Guard	Gehäuse	Carter	Cárter		
2	✓		220063	TCB M4,2x13	TCB M4.2x13 bolt	Schraube M4,2x13	Vis M4,2x13	Tornillo M4,2x13		
3	✓		236025	Rosetta d. 4,3x9x0,8	D. 4.3x9x0.8 washer	Unterlegscheibe d. 4,3x9x0,8	Rondelle d. 4,3x9x0,8	Arandela d. 4,3x9x0,8		

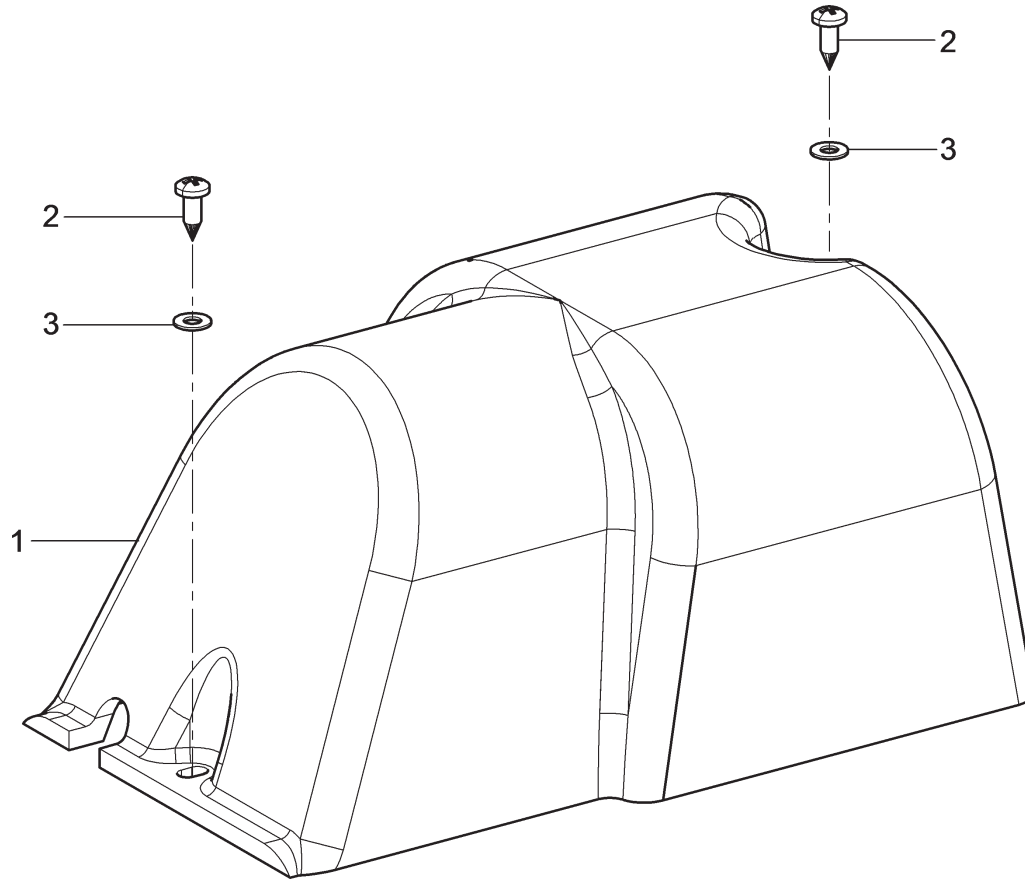

ROT. HP441.201102	ROT. HP641.200838	ROT. HF641.201034	ROT. HP641.200891	ROT. HF641.200785	ROT.HF641.201063 ROT.HF641.201788	ROT. HF641.201072	ROT. HF641.201065	ROT. HF641.201897	ROT.HF643.200894 ROT.HF643.201881	ROT. HP643.201133	ROT. HF643.200983	RAV. G7441.201140	RAV. G7441.200969	RAV. G7441.201119	RAV. G7441.200716	RAV. G7441.200877	RAV. G7441.200821	RAV. G7641.200945	RAV. G7641.200006	RAV. G7641.201041	RAV.G7641.200907 RAV.G7641.200683	RAV. G7641.201010	RAV. G7641.201089	RAV. G7641.200761	RAV. G7645.201232	RAV. G7645.200914	RAV. G7645.200890	RAV. G8645.201249	SFA. GA441.200976	SPA. GA441.201126	SFA. GA441.202000	SFA. GA641.201027	SFA. GA641.201096	SFA. GA641.200952	SFA. GA641.201058	SFA. GA645.200600							
								•	•	•																																	
												<b>LISTA DEI COMPONENTI - LIST OF COMPONENTS - TEILELISTE</b> <b>LISTE DES PIÈCES DÉTACHÉES - LISTA DE PIEZAS</b>										COPERTURA PALO POST COVER STANGENABDECKUNG COUVERTURE POTEAU COBERTURA PALO																					
Tavola N°25B - Rev. 0												730097560																		<b>Pag. 181 di 235</b>													

Tavola N°25B - Rev. 0

730097560

ROT. HP441.201102	ROT. HP641.200938	ROT. HP641.201034	ROT. HP641.200891	ROT. HP641.200785	ROT. HP641.201003	ROT. HP641.201788	ROT. HP641.201072	ROT. HP641.201065	ROT. HP641.201997	ROT. HP643.200984	ROT. HP643.201881	ROT. HP643.201133	ROT. HP643.200983	RAV. G7441.201140	RAV. G7441.200969	RAV. G7441.201119	RAV. G7441.200716	RAV. G7441.200877	RAV. G7441.200921	RAV. G7641.200945	RAV. G7641.200006	RAV. G7641.201041	RAV. G7641.200907	RAV. G7641.200689	RAV. G7641.201010	RAV. G7641.201089	RAV. G7641.200761	RAV. G7645.201232	RAV. G7645.200914	RAV. G7645.200990	RAV. G8645.201249	SFA. GA441.200976	SFA. GA441.201126	SFA. GA441.202000	SFA. GA641.201027	SFA. GA641.201096	SFA. GA641.200952	SFA. GA641.201058	SFA. GA645.200600					
										●	●	●																																
#		D.R	N	Descrizione	Description	Beschreibung	Description	Descripción																																				

1	✓		730015340	Carter posteriore	Rear guard	Hinteres Gehäuse	Carter postérieur	Cárter posterior				
2	✓		220063	TCB M4,2x13	TCB M4.2x13 bolt	Schraube M4,2x13	Vis M4,2x13	Tornillo M4,2x13				
3	✓		236025	Rosetta d. 4,3x9x0,8	D. 4.3x9x0.8 washer	Unterlegscheibe d. 4,3x9x0,8	Rondelle d. 4,3x9x0,8	Arandela d. 4,3x9x0,8				

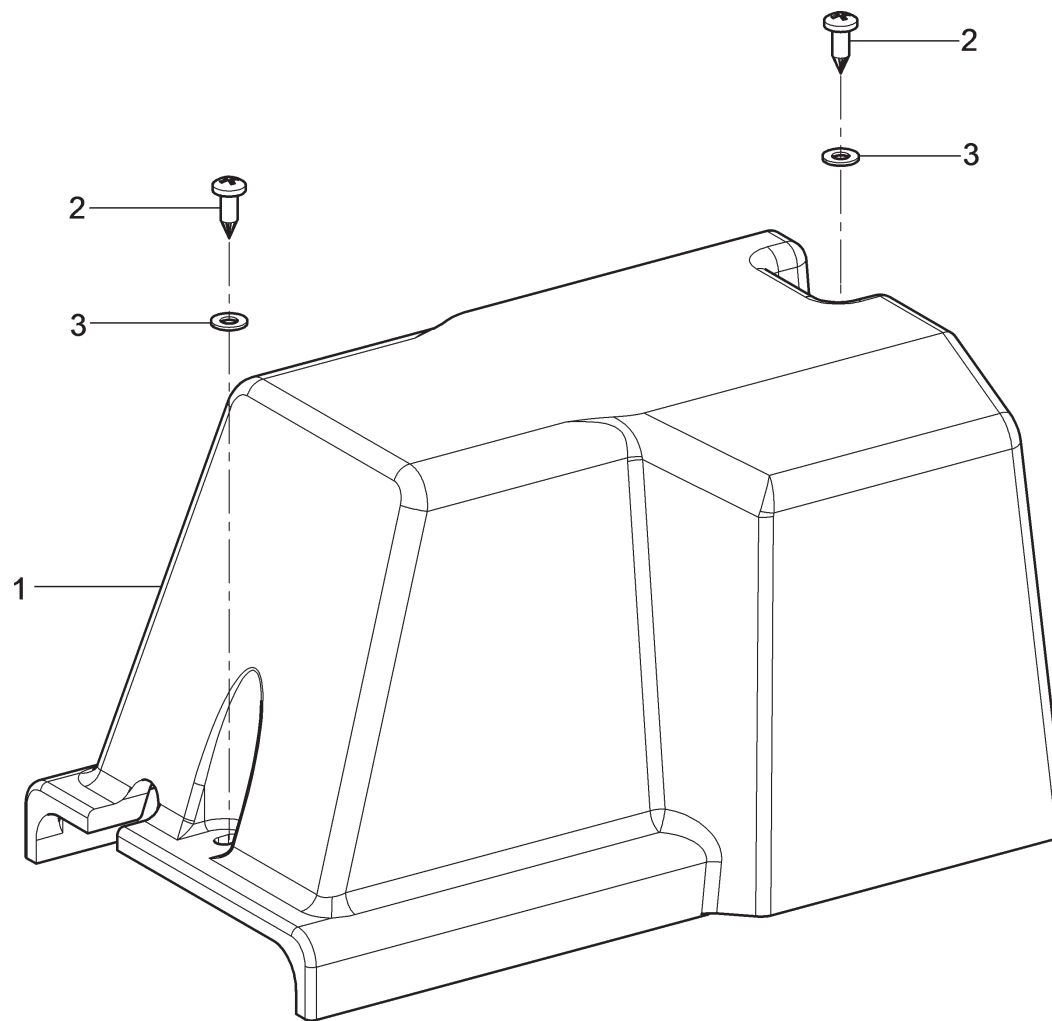

ROT. HP441.201102	ROT. HP641.200838	ROT. HF641.201034	ROT. HP641.200891	ROT. HF641.200785	ROT.HP641.201063 ROT.HP641.201788	ROT. HF641.201072	ROT. HF641.201065	ROT. HF641.201897	ROT.HP643.200884 ROT.HP643.201881	ROT. HP643.201133	ROT. HF643.200983	RAV. G7441.201140	RAV. G7441.200969	RAV. G7441.201119	RAV. G7441.200716	RAV. G7441.200877	RAV. G7441.200821	RAV. G7641.200945	RAV. G7641.200006	RAV. G7641.201041	RAV.G7641.200907 RAV.G7641.200683	RAV. G7641.201010	RAV. G7641.201089	RAV. G7641.200761	RAV. G7645.201232	RAV. G7645.200914	RAV. G7645.200890	RAV. G8645.201249	SFA. GA441.200976	SPA. GA441.201126	SFA. GA441.202000	SFA. GA641.201027	SFA. GA641.201096	SFA. GA641.200952	SFA. GA641.201058	SFA. GA645.200600			
												•	•	•	•	•	•	•	•	•	•	•	•						•	•	•	•	•	•	•	•	•	•	•
		<b>LISTA DEI COMPONENTI - LIST OF COMPONENTS - TEILELISTE</b> <b>LISTE DES PIECES DETACHEES - LISTA DE PIEZAS</b>																			COPERTURA PALO POST COVER STANGENABDECKUNG COUVERTURE POTEAU COBERTURA PALO																		
		<b>Tavola N°25C - Rev. 0</b>									<b>730098210</b>									<b>Pag. 183 di 235</b>																			







LISTA DEI COMPONENTI - LIST OF COMPONENTS - TEILELISTE  
LISTE DES PIECES DETACHEES - LISTA DE PIEZAS

COPERTURA PALO  
POST COVER  
STANGENABDECKUNG  
COUVERTURE POTEAU  
COBERTURA PALO

Tavola N°25D - Rev. 0

730097830

ROT. HF441.201102	ROT. HF641.200938	ROT. HF641.201034	ROT. HF641.200891	ROT. HF641.200785	ROT.HF641.201003 ROT.HF641.201788	ROT. HF641.201072	ROT. HF641.201065	ROT. HF641.201997	ROT.HF643.200984 ROT.HF643.201681	ROT. HF643.201133	ROT. HF643.200983	RAV G7441.201140	RAV G7441.200969	RAV G7441.201119	RAV G7441.200716	RAV G7441.200877	RAV G7441.200921	RAV G7641.200945	RAV G7641.200006	RAV G7641.201041	RAV.G7641.200907 RAV.G7641.200689	RAV G7641.201010	RAV G7641.201089	RAV G7641.200761	RAV G7645.201232	RAV G7645.200914	RAV G7645.200990	RAV GS8645.201249	SFA GA441.200976	SFA GA441.201126	SFA GA441.202000	SFA GA641.201027	SFA GA641.201096	SFA GA641.200952	SFA GA641.201058	SFA GA645.200600
----------------------	----------------------	----------------------	----------------------	----------------------	--------------------------------------	----------------------	----------------------	----------------------	--------------------------------------	----------------------	----------------------	---------------------	---------------------	---------------------	---------------------	---------------------	---------------------	---------------------	---------------------	---------------------	--------------------------------------	---------------------	---------------------	---------------------	---------------------	---------------------	---------------------	----------------------	---------------------	---------------------	---------------------	---------------------	---------------------	---------------------	---------------------	---------------------

#		D.R	N	Descrizione	Description	Beschreibung	Description	Descripción		
---	--	-----	---	-------------	-------------	--------------	-------------	-------------	--	--

1	✓		140302151	Carter superiore	Upper guard	Oberes Gehäuse	Carter supérieur	Cárter superior		
2	✓		220063	TCB M4,2x13	TCB M4.2x13 bolt	Schraube M4,2x13	Vis M4,2x13	Tornillo M4,2x13		
3	✓		236025	Rosetta d. 4,3x9x0,8	D. 4.3x9x0.8 washer	Unterlegscheibe d. 4,3x9x0,8	Rondelle d. 4,3x9x0,8	Arandela d. 4,3x9x0,8		





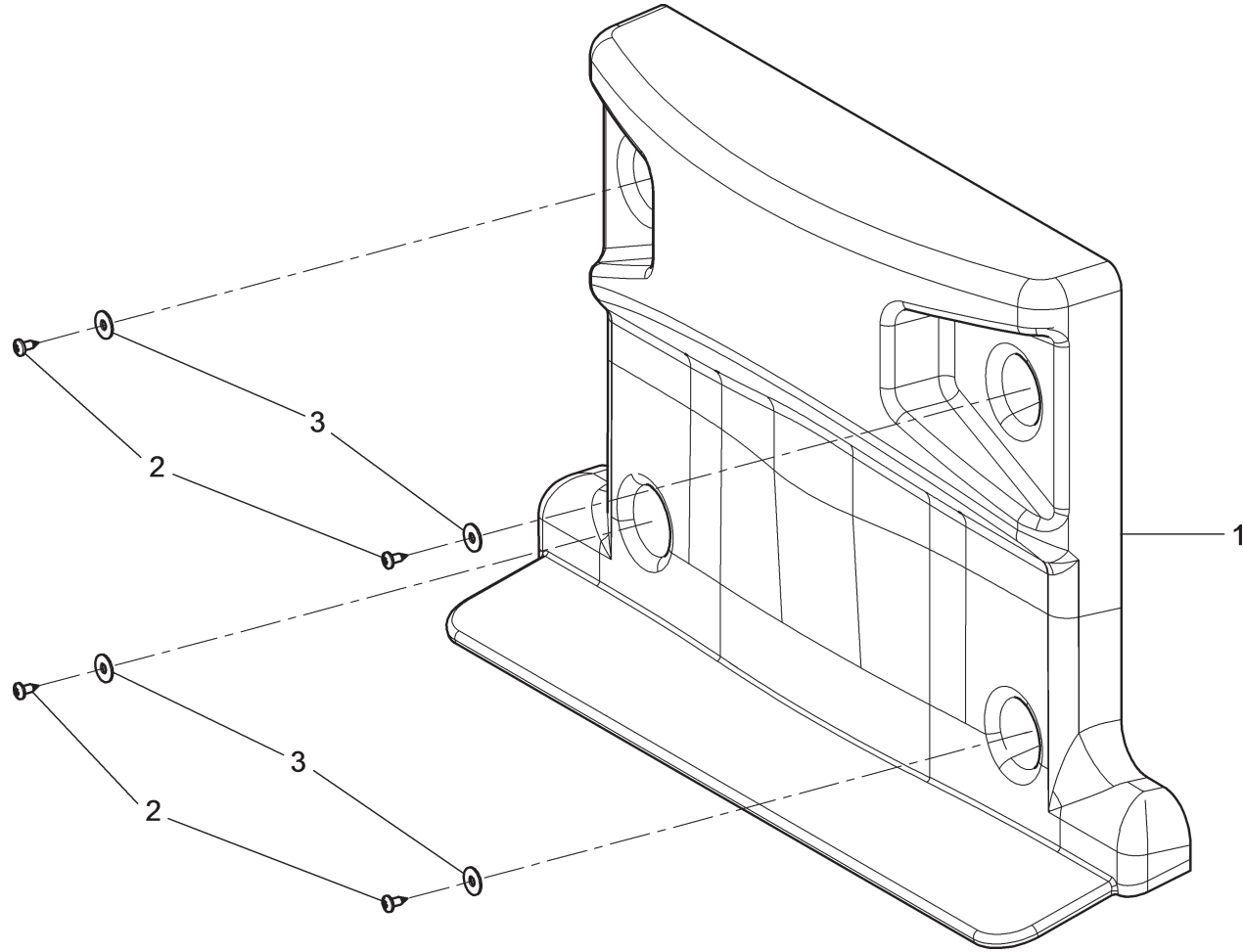

ROT. HP441.201102	ROT. HP641.200838	ROT. HF641.201034	ROT. HP641.200891	ROT. HF641.200785	ROT.HF641.201063 ROT.HF641.201788	ROT. HP641.201072	ROT. HP641.201065	ROT. HP641.201897	ROT.HF643.200894 ROT.HF643.201881	ROT. HP643.201133	ROT. HF643.200983	RAV. G7441.201140	RAV. G7441.200969	RAV. G7441.201119	RAV. G7441.200716	RAV. G7441.200877	RAV. G7441.200821	RAV. G7641.200945	RAV. G7641.200006	RAV. G7641.201041	RAV.G7641.200907 RAV.G7641.200683	RAV. G7641.201010	RAV. G7641.201089	RAV. G7641.200761	RAV. G7645.201232	RAV. G7645.200914	RAV. G7645.200990	RAV. G8645.201249	SFA. GA441.200976	SPA. GA441.201126	SFA. GA441.202000	SPA. GA641.201027	SFA. GA641.201096	SPA. GA641.200952	SPA. GA641.201058	SPA. GA645.200600
----------------------	----------------------	----------------------	----------------------	----------------------	--------------------------------------	----------------------	----------------------	----------------------	--------------------------------------	----------------------	----------------------	----------------------	----------------------	----------------------	----------------------	----------------------	----------------------	----------------------	----------------------	----------------------	--------------------------------------	----------------------	----------------------	----------------------	----------------------	----------------------	----------------------	----------------------	----------------------	----------------------	----------------------	----------------------	----------------------	----------------------	----------------------	----------------------

	<b>LISTA DEI COMPONENTI - LIST OF COMPONENTS - TEILELISTE</b> <b>LISTE DES PIÈCES DÉTACHÉES - LISTA DE PIEZAS</b>																				 			
	<b>Tavola N°26B - Rev. 0</b>										<b>730097510</b>										CARTER FRONTALE FRONT GUARD VORDERES GEHÄUSE CARTER FRONTAL CARTER ANTERIOR		<b>Pag. 189 di 235</b>	



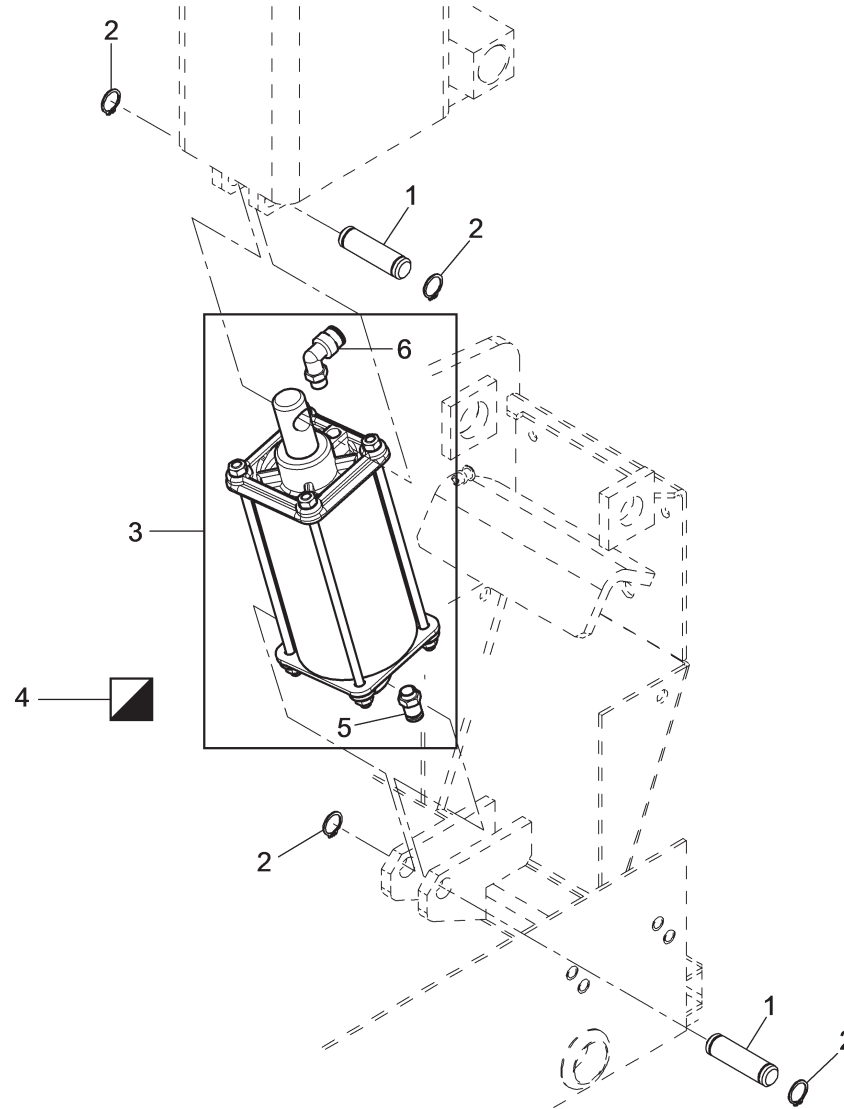

ROT. HP441.201102	ROT. HP641.200838	ROT. HF641.201034	ROT. HP641.200891	ROT. HF641.200785	ROTI:HP641.201063 ROTI:HP641.201788	ROT. HP641.201072	ROT. HP641.201065	ROT. HP641.201897	ROTI:HP643.200884 ROTI:HP643.201881	ROT. HP643.201133	ROT. HF643.200883	RAV. G7441.201140	RAV. G7441.200969	RAV. G7441.201119	RAV. G7441.200716	RAV. G7441.200877	RAV. G7441.200821	RAV. G7641.200945	RAV. G7641.200006	RAV. G7641.201041	RAV:G7641.200907 RAV:G7641.200683	RAV. G7641.201010	RAV. G7641.201089	RAV. G7641.200761	RAV. G7645.201232	RAV. G7645.200914	RAV. G7645.200990	RAV. G8645.201249	SFA. GA441.200976	SPA. GA441.201126	SFA. GA441.202000	SPA. GA641.201027	SFA. GA641.201096	SPA. GA641.200952	SPA. GA641.201058	SPA. GA645.200600		
●												●	●	●	●	●	●												●	●	●							



LISTA DEI COMPONENTI - LIST OF COMPONENTS - TEILELISTE  
LISTE DES PIÉCES DÉTACHÉES - LISTA DE PIEZAS

Tavola N°27A - Rev. 0

730091270

GRUPPO PISTONE RIBALTAMENTO PALO  
TILTING POST PISTON ASSEMBLY  
STANGENEINHEITSSKIPPUNG-KOLBENSATZ  
ENSEMBLE PISTON BASCULAGE POTEAU  
CONJUNTO PISTÓN VUELCO PALO



LISTA DEI COMPONENTI - LIST OF COMPONENTS - TEILELISTE  
LISTE DES PIECES DETACHEES - LISTA DE PIEZAS

GRUPPO PISTONE RIBALTAMENTO PALO  
TILTING POST PISTON ASSEMBLY  
STANGENEINHEITSSKIPPUNG-KOLBENSATZ  
ENSEMBLE PISTON BASCULAGE POTEAU  
CONJUNTO PISTÓN VUELCO PALO

Tavola N°27A - Rev. 0

730091270

#	D.R	N	Descrizione	Description	Beschreibung	Description	Descripción		
1	✓	14030131	Perno	Pin	Zapfen	Pivot	Perno		
2	✓	243006	Seeger est.14 7435	External clip ring 14 7435	Externer Seeger 14 7435	Anneau de retenue extérieur 14 7435	Seeger esterno 14 7435		
3	✓	730091250	Cilindro ribaltamento palo D.70	D.70 post tilting cylinder	Umkippzylinder der Stange D.70	Cylindre basculement poteau D.70	Cilindro volcado palo D.70		
4	✓	GU4870	Kit guarnizione cilindro D.70	Cylinder gasket kit D.70	Zylinderdichtungenset D.70	Kit joint cylindre D.70	Kit junta cilindro D.70		
5	✓	325110	Raccordo	Fitting	Anschluss	Raccord	Empalme		
6	✓	325159	Raccordo a L	L-shaped fitting	L-Anschluss	Raccord à L	Empalme en L		

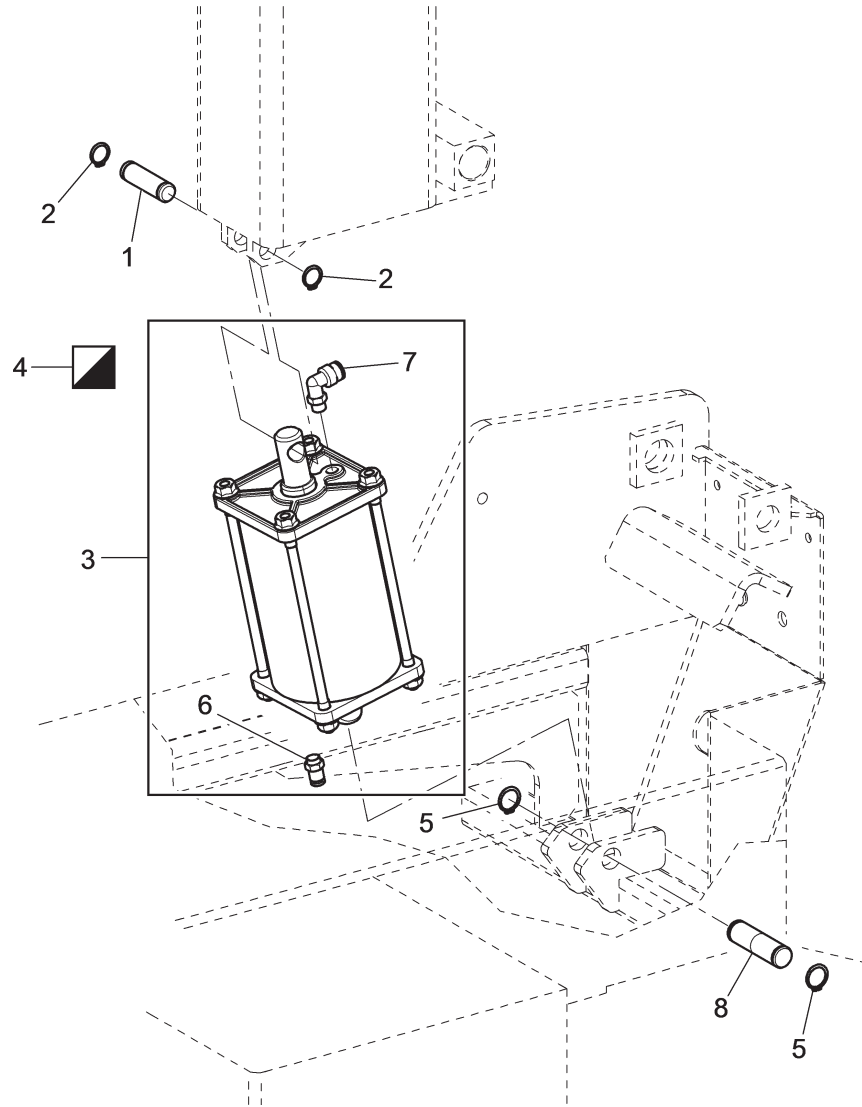

ROT. HP441.201102	•	ROT. HP641.200838	•	ROT. HF641.201034	•	ROT. HP641.200891	•	ROT. HF641.200785	•	ROT:HP641.201063	•	ROT:HP641.201788	•	ROT. HP641.201072	•	ROT. HF641.201065	•	ROT. HP641.201897	•	ROT:HP643.200884	•	ROT:HP643.201881	•	ROT. HP643.201133	•	ROT. HF643.200983	•	RAV. G7441.201140	•	RAV. G7441.200969	•	RAV. G7441.201119	•	RAV. G7441.200716	•	RAV. G7441.200877	•	RAV. G7441.200821	•	RAV. G7641.200945	•	RAV. G7641.200006	•	RAV. G7641.201041	•	RAV:G7641.200907	•	RAV:G7641.200683	•	RAV. G7641.201010	•	RAV. G7641.201089	•	RAV. G7641.200761	•	RAV. G7645.201232	•	RAV. G7645.200914	•	RAV. G7645.200890	•	RAV. G8645.201249	•	SFA. GA441.200876	•	SPA. GA441.201126	•	SFA. GA441.202000	•	SFA. GA641.201027	•	SFA. GA641.201096	•	SFA. GA641.200952	•	SFA. GA641.201058	•	SFA. GA645.200600	•
		<b>LISTA DEI COMPONENTI - LIST OF COMPONENTS - TEILELISTE</b> <b>LISTE DES PIÈCES DÉTACHÉES - LISTA DE PIEZAS</b>																								<b>GRUPPO CILINDRO RIBALTAMENTO</b> <b>TILTING CYLINDER ASSEMBLY</b> <b>ZYLINDERSKIPPUNGSATZÜ</b> <b>ENSEMBLE CYLINDRE BASCULAGE</b> <b>CONJUNTO CILINDRO VUELCO</b>												▶																																									
		<b>Tavola N°27B - Rev. 0</b>												<b>730092590</b>												<b>Pag. 193 di 235</b>																																																					



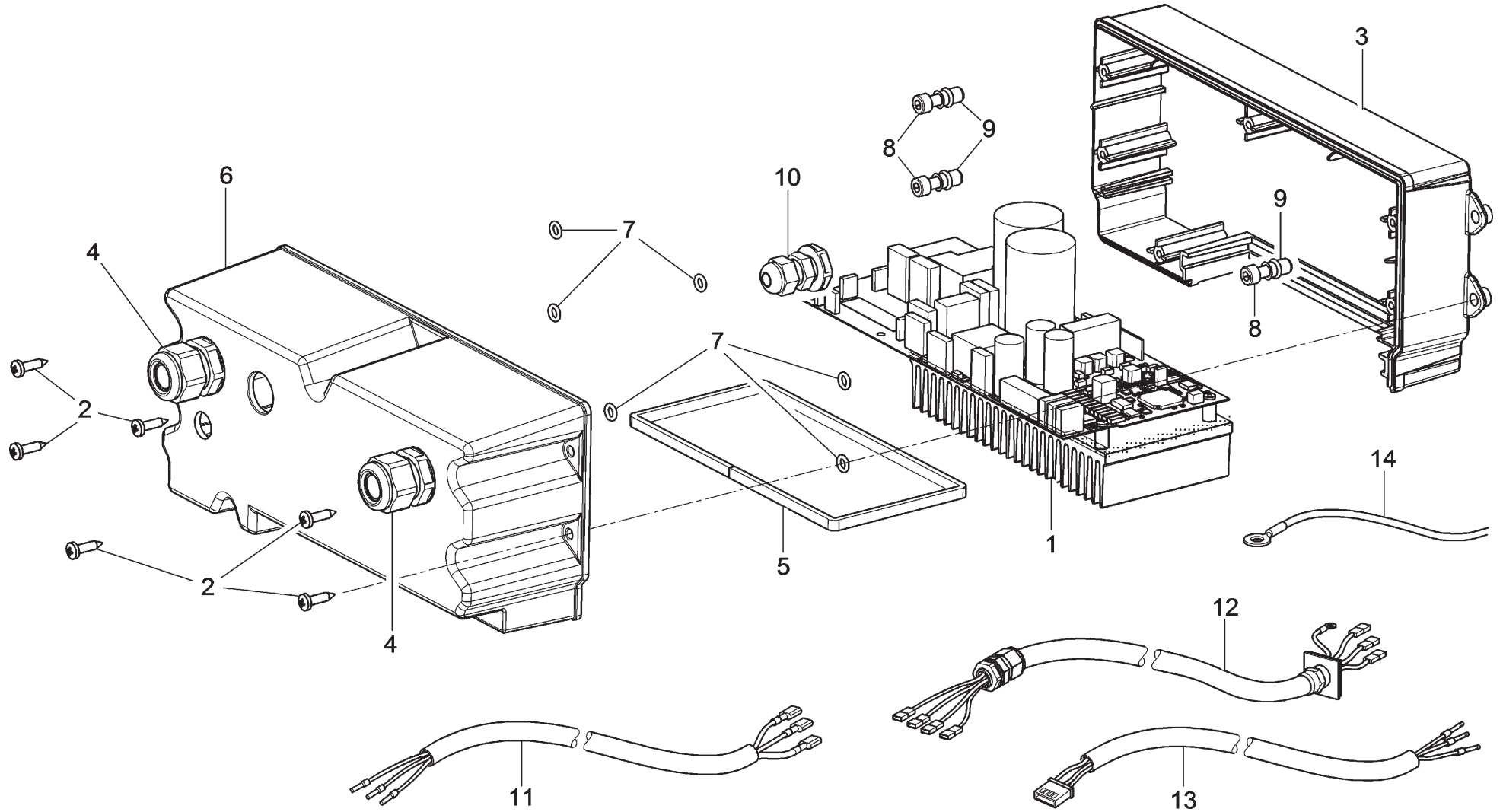

ROT. HP441.201102	ROT. HP641.200838	ROT. HP641.201034	ROT. HP641.200891	ROT. HP641.200785	ROT.HP641.201003	ROT.HP641.201788	ROT. HP641.201072	ROT. HP641.201065	ROT. HP641.201897	ROT.HP643.200684	ROT.HP643.201881	ROT. HP643.201133	ROT. HP643.200983	RAV. G7441.201140	RAV. G7441.200969	RAV. G7441.201119	RAV. G7441.200716	RAV. G7441.200877	RAV. G7441.200821	RAV. G7641.200945	RAV. G7641.200006	RAV. G7641.201041	RAV.G7641.200907	RAV.G7641.200683	RAV. G7641.201010	RAV. G7641.201089	RAV. G7641.200761	RAV. G7645.201232	RAV. G7645.200914	RAV. G7645.200990	RAV. G8645.201249	SFA. GA441.200976	SFA. GA441.201126	SFA. GA441.202000	SFA. GA641.201027	SFA. GA641.201096	SFA. GA641.200952	SFA. GA641.201058	SFA. GA645.200600
	•	•	•	•						•	•	•								•	•	•	•				•	•	•	•							•	•	•
		<b>LISTA DEI COMPONENTI - LIST OF COMPONENTS - TEILELISTE</b> <b>LISTE DES PIÈCES DÉTACHÉES - LISTA DE PIEZAS</b>																		GRUPPO INVERTER INVERTER ASSEMBLY FREQUENZUMFORMERSATZ ENSEMBLE INVERSEUR CONJUNTO INVERSOR								<b>Pag. 195 di 235</b>											
		Tavola N°28 - Rev. 1									730096861																												





LISTA DEI COMPONENTI - LIST OF COMPONENTS - TEILELISTE  
LISTE DES PIECES DETACHEES - LISTA DE PIEZAS

GRUPPO INVERTER  
INVERTER ASSEMBLY  
FREQUENZUMFORMERSATZ  
ENSEMBLE INVERSEUR  
CONJUNTO INVERSOR

Pag. 196 di 235

Tavola N°28 - Rev. 1

730096861

#		D.R	N	Descrizione	Description	Beschreibung	Description	Descripción		
---	---	-----	---	-------------	-------------	--------------	-------------	-------------	---	---

1	✓		20788	Scheda inverter	Inverter board	Frequenzumformerplatte	Carte inverseur	Tarjeta invector		
2	✓		220061	TCB 3,9x16	3,9x16 TCB bolt	Schraube TCB 3,9x16	Vis TCB 3,9x16	Tornillo TCB 3,9x16		
3	✓		790013161	Fondo scatola inverter	Inverter box bottom	Boden des Frequenzumformerkastens	Fond boîte inverseur	Fondo caja invector		
4	✓		599445	Pressacavo	Cable press	Kabeldurchführung	Presse-câble	Prensaestopas		
5	✓		790013180	Nastro in gomma	Rubber tape	Gummiband	Ruban en caoutchouc	Cinta de goma		
6	✓		790013172	Coperchio con inverter	Inverter cover	Abdeckung mit Frequenzumformer	Couvercle avec inverseur	Tapa con invector		
7	✓		401028	OR	OR	OR	OR	OR		
8	✓		206146	TCEI M5x16	TCEI M5x16 bolt	Schraube TCEI M5x16	Vis TCEI M5x16	Tornillo TCEI M5x16		
9	✓		B9751000	Inserto filettato M5	M5 threaded insert	Gewindeinsatz M5	Renfort fileté M5	Inserto roscado M5		
10	✓		599300	Pressacavo	Cable press	Kabeldurchführung	Presse-câble	Prensaestopas		
11	✓		730065321	Cavo alimentazione inverter	Inverter supply cable	Stromkabel des Frequenzumformers	Câble alimentation inverseur	Cable alimentación invector		
12	✓		730065210	Insieme cavo inverter	Inverter cable assembly	Frequenzumformerkabelsatz	Ensemble câble inverseur	Conjunto cable invector		
13	✓		710565021	Cavo segnali inverter	Inverter signal cable	Frequenzumformer-Signalkabel	Câble signaux inverseur	Cable señales invector		
14	✓		790065190	Cavo di terra	Ground cable	Erdkabel	Câble de masse	Cable de tierra		

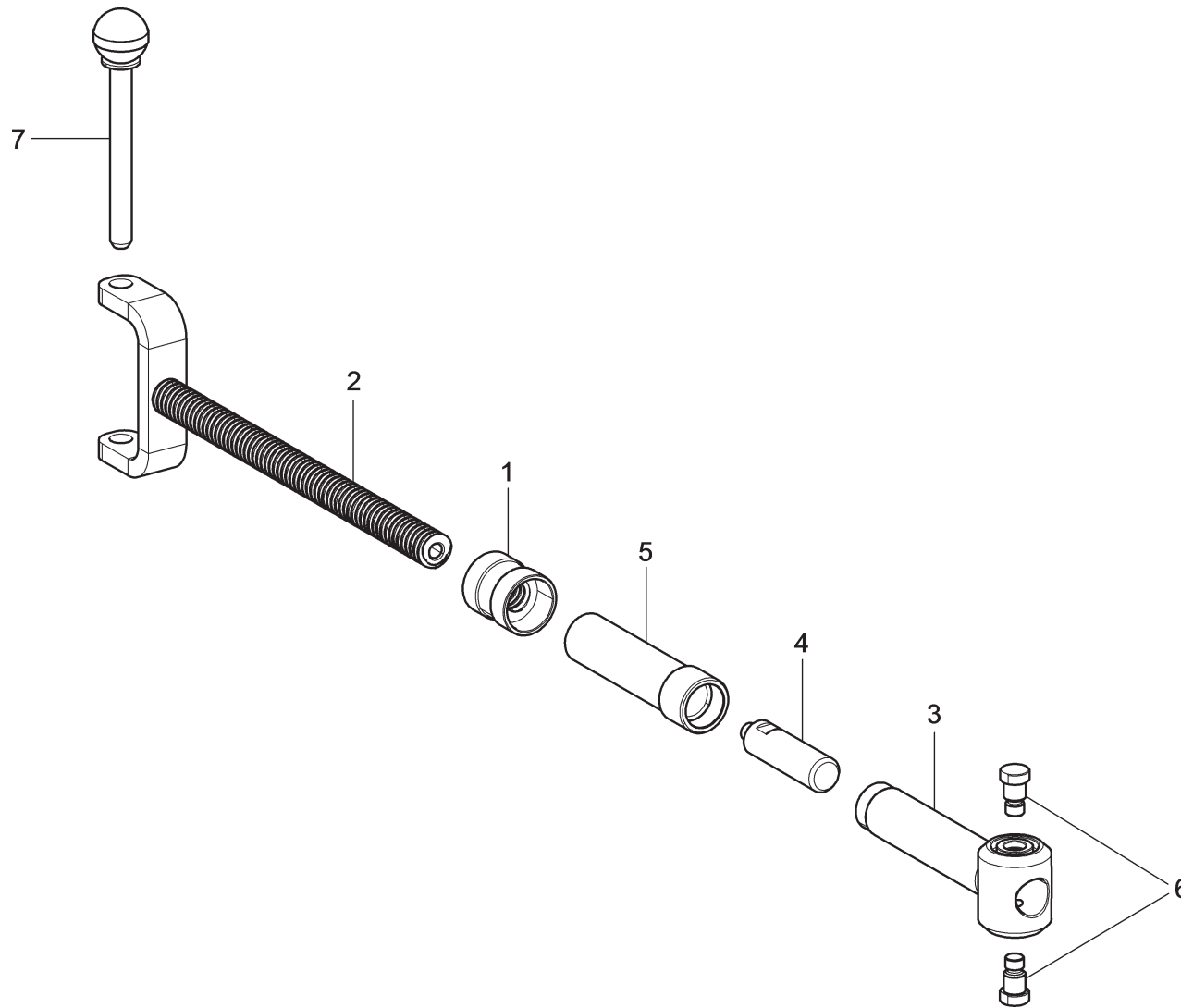

ROT. HP441.201102	ROT. HP641.200838	ROT. HF641.201034	ROT. HP641.200891	ROT. HF641.200785	ROT.HF641.201063 ROT.HF641.201788	ROT. HP641.201072	ROT. HF641.201065	ROT. HF641.201897	ROT.HF643.200894 ROT.HF643.201881	ROT. HP643.201133	ROT. HF643.200983	RAV. G7441.201140	RAV. G7441.200969	RAV. G7441.201119	RAV. G7441.200716	RAV. G7441.200877	RAV. G7441.200921	RAV. G7641.200945	RAV. G7641.200006	RAV. G7641.201041	RAV.G7641.200907 RAV.G7641.200693	RAV. G7641.201010	RAV. G7641.201089	RAV. G7641.200761	RAV. G7645.201232	RAV. G7645.200914	RAV. G7645.200990	RAV. G8645.201249	SFA. GA441.200976	SPA. GA441.201126	SFA. GA441.202000	SFA. GA641.201027	SFA. GA641.201096	SFA. GA641.200952	SFA. GA641.201058	SFA. GA645.200600						
			•	•			•		•	•	•																															
			<b>LISTA DEI COMPONENTI - LIST OF COMPONENTS - TEILELISTE</b> <b>LISTE DES PIÈCES DÉTACHÉES - LISTA DE PIEZAS</b>																		GRUPPO LIMITATORE DI CORSA STROKE LIMITING DEVICE ASSEMBLY HUBBEGRENZERSATZ ENSEMBLE LIMITEUR DE COURSE CONJUNTO LIMITADOR DE CARRERA						 		<b>Pag. 197 di 235</b>													
			<b>Tavola N°29 - Rev. 0</b>						<b>770090370</b>						<b>Pag. 197 di 235</b>																											



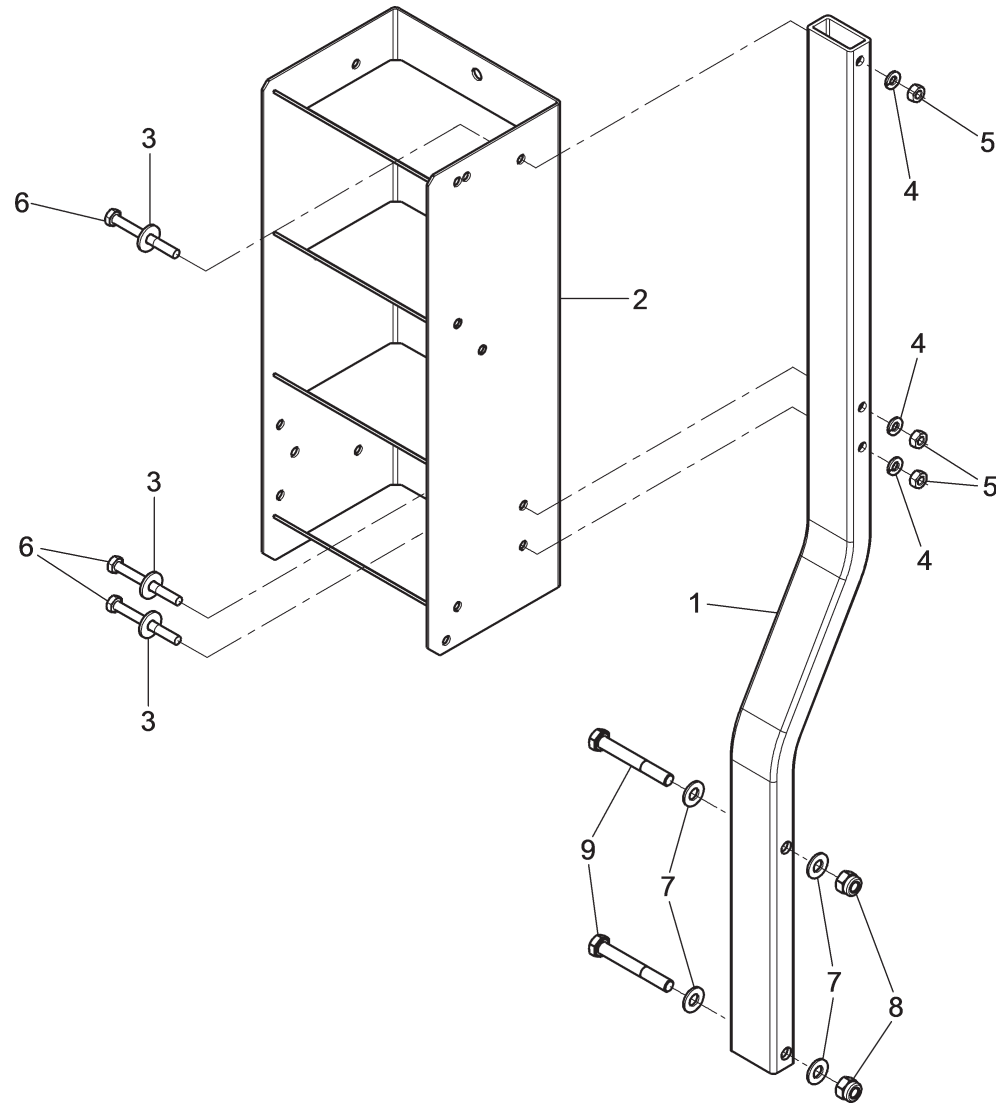

ROT. HP441.201102	ROT. HP641.200838	ROT. HF641.201034	ROT. HP641.200891	ROT. HF641.200785	ROT. HP641.201063	ROT. HP641.201788	ROT. HF641.201072	ROT. HF641.201065	ROT. HP641.201897	ROT. HP643.200884	ROT. HP643.201881	ROT. HP643.201133	ROT. HF643.200983	RAV. G7441.201140	RAV. G7441.200969	RAV. G7441.201119	RAV. G7441.200716	RAV. G7441.200877	RAV. G7441.200821	RAV. G7641.200945	RAV. G7641.200006	RAV. G7641.201041	RAV. G7641.200907	RAV. G7641.200683	RAV. G7641.201010	RAV. G7641.201089	RAV. G7641.200761	RAV. G7645.201232	RAV. G7645.200914	RAV. G7645.200890	RAV. G8645.201249	SFA. GA441.200976	SPA. GA441.201126	SFA. GA441.202000	SPA. GA641.201027	SPA. GA641.201096	SPA. GA641.200952	SPA. GA641.201058	SPA. GA645.200600				
				•												•			•			•																					



LISTA DEI COMPONENTI - LIST OF COMPONENTS - TEILELISTE  
LISTE DES PIÈCES DÉTACHÉES - LISTA DE PIEZAS

Tavola N°30 - Rev. 0

770090410

PORTAOGGETTI  
TOOL BOX  
OBJEKTTRÄGER  
PORTE-OBJETS  
PORTA-OBJETOS



Pag. 199 di 235



•	ROT. HP441.201102	•	ROT. HP641.200838	•	ROT. HP641.201034		ROT. HP641.200891	•	ROT. HP641.200785		ROT. HP641.201072		ROT. HP641.201065		ROT. HP641.201897		ROT. HP643.200884		ROT. HP643.201881		ROT. HP643.201133		ROT. HP643.200883		RAV. G7441.201140		RAV. G7441.200869		RAV. G7441.201119	•	RAV. G7441.200716		RAV. G7441.200877	•	RAV. G7441.200821		RAV. G7641.200845		RAV. G7641.200006	•	RAV. G7641.201041		RAV. G7641.200907		RAV. G7641.200983	•	RAV. G7641.201010		RAV. G7641.201089	•	RAV. G7641.200761		RAV. G7645.201232	•	RAV. G7645.200914	•	RAV. G7645.200890		RAV. G8645.201249		SFA. GA441.200876		SPA. GA441.201126	•	SFA. GA441.202000	•	SFA. GA641.201027	•	SFA. GA641.201096	•	SFA. GA641.200852	•	SFA. GA641.201058	•	SFA. GA645.200600	•
		<b>LISTA DEI COMPONENTI - LIST OF COMPONENTS - TEILELISTE</b> <b>LISTE DES PIÈCES DÉTACHÉES - LISTA DE PIEZAS</b>												KIT DOTAZIONE ACCESSORY KIT ASSEMBLY AUSSTATTUNGSSET KIT DOTATION KIT DOTACIÓ												▶																																																		
<b>Tavola N°31A - Rev. 0</b>		<b>730097900</b>																								▶																																																		
																										<b>Pag. 201 di 235</b>																																																		

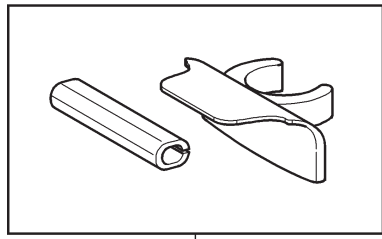

1

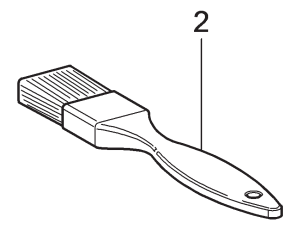

2

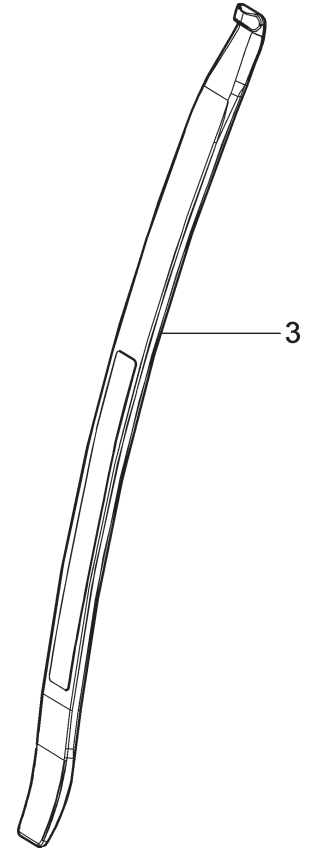

3



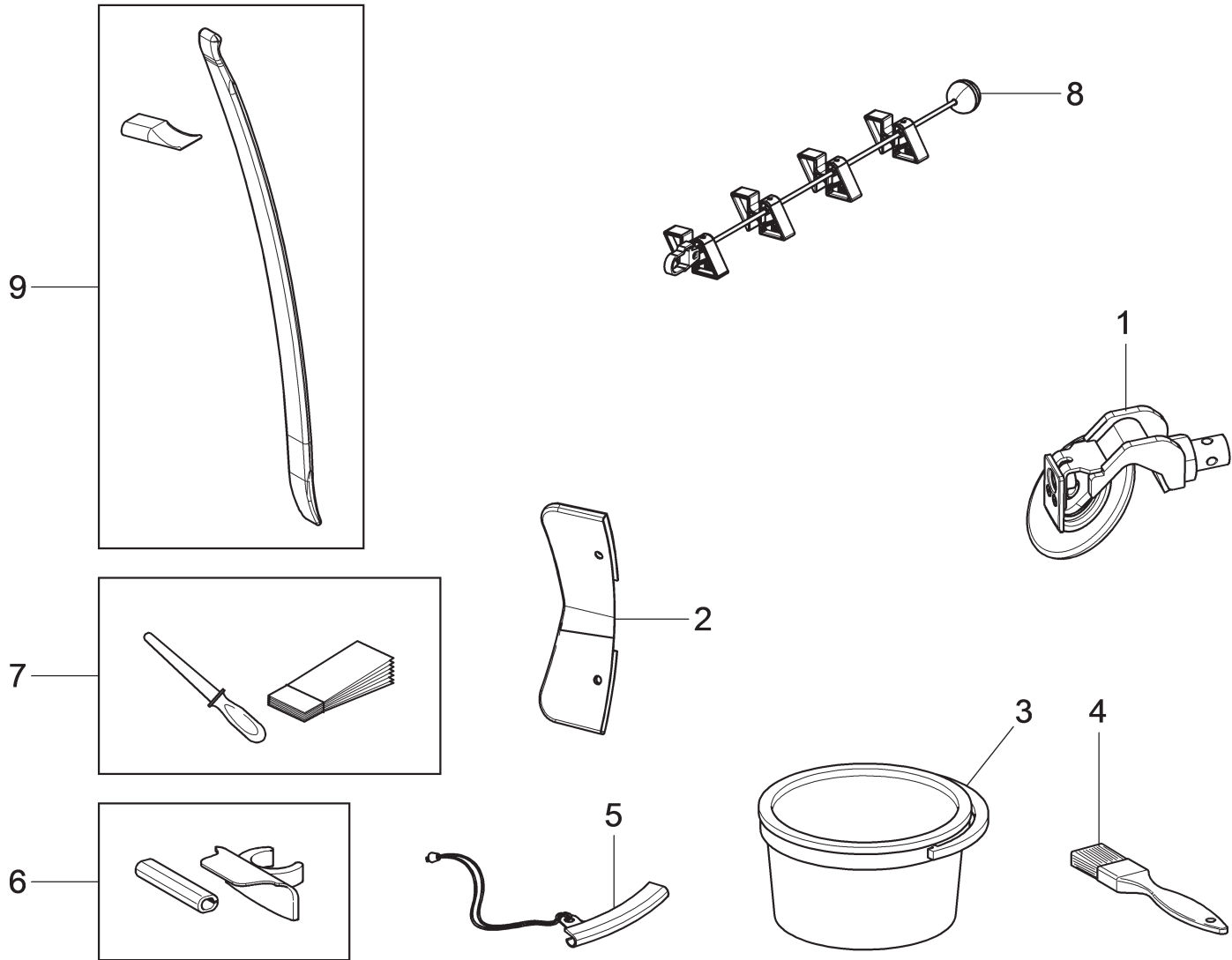

ROT. HP441.201102	ROT. HP641.200838	ROT. HF641.201034	ROT. HP641.200891	ROT. HF641.200785	ROT.HF641.201063 ROT.HF641.201788	ROT. HP641.201072	ROT. HP641.201065	ROT. HP641.201897	ROT.HF643.200884 ROT.HF643.201881	ROT. HP643.201133	ROT. HF643.200983	RAV. G7441.201140	RAV. G7441.200969	RAV. G7441.201119	RAV. G7441.200716	RAV. G7441.200877	RAV. G7441.200821	RAV. G7641.200945	RAV. G7641.200006	RAV. G7641.201041	RAV.G7641.200907 RAV.G7641.200683	RAV. G7641.201010	RAV. G7641.201089	RAV. G7641.200761	RAV. G7645.201232	RAV. G7645.200914	RAV. G7645.200990	RAV. G8645.201249	SFA. GA441.200976	SFA. GA441.201126	SFA. GA441.202000	SFA. GA641.201027	SFA. GA641.201096	SFA. GA641.200952	SFA. GA641.201058	SFA. GA645.200600			
			•			•		•	•	•																													
		<b>LISTA DEI COMPONENTI - LIST OF COMPONENTS - TEILELISTE</b> <b>LISTE DES PIÈCES DÉTACHÉES - LISTA DE PIEZAS</b>																			KIT DOTAZIONE ACCESSORY KIT ASSEMBLY AUSSTATTUNGSSET KIT DOTACIÓN KIT DOTACIÓ																		
		Tavola N°31B - Rev. 0			730097700			<b>Pag. 203 di 235</b>																															



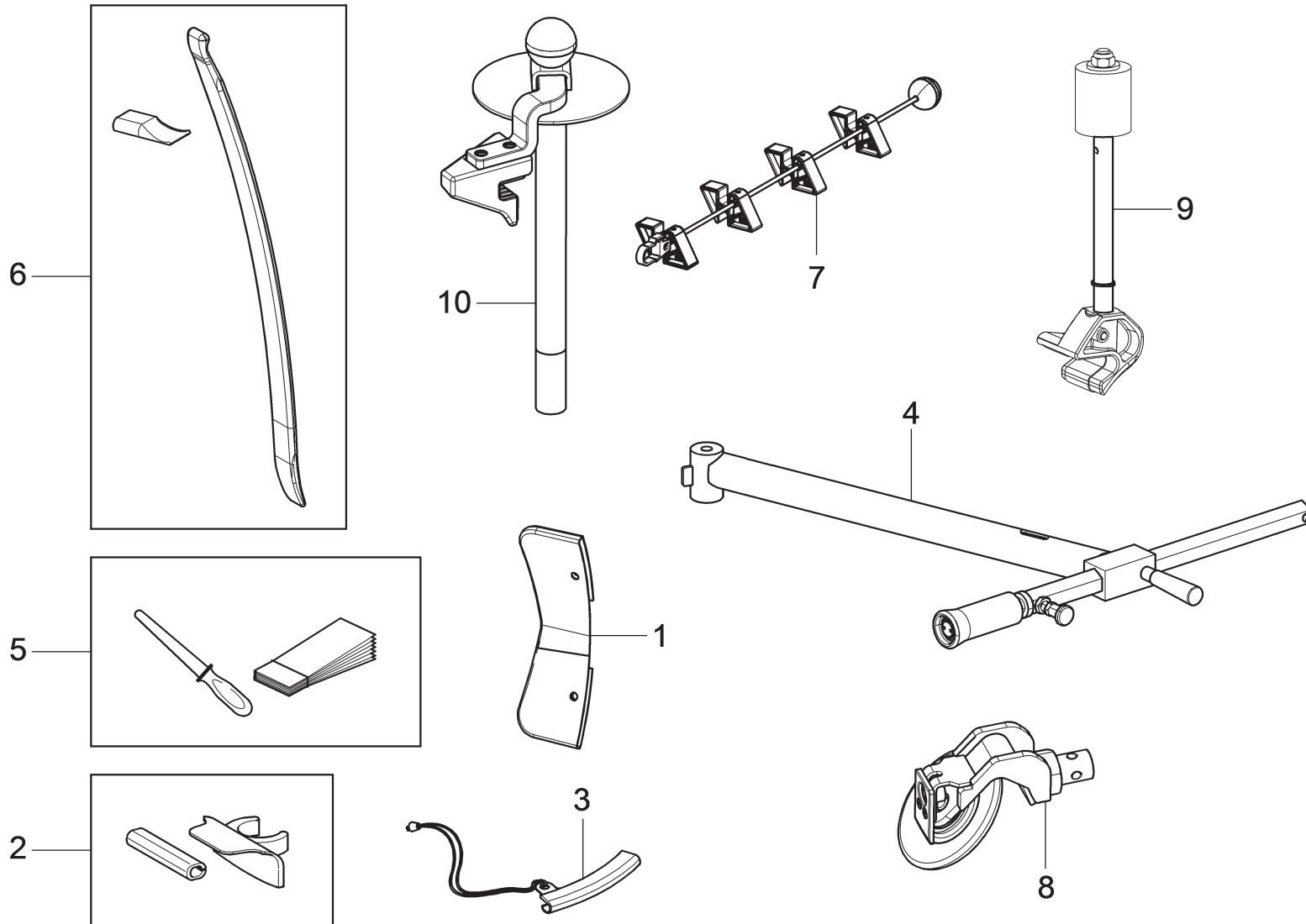

ROT. HP441.201102	ROT. HP641.200838	ROT. HF641.201034	ROT. HP641.200891	ROT. HP641.200785	ROT. HP641.201072	ROT. HP641.201065	ROT. HP641.201897	ROT. HP643.200894	ROT. HP643.201881	ROT. HP643.201133	ROT. HF643.200983	RAV. G7441.201140	RAV. G7441.200969	RAV. G7441.201119	RAV. G7441.200716	RAV. G7441.200877	RAV. G7441.200821	RAV. G7641.200945	RAV. G7641.200006	RAV. G7641.201041	RAV. G7641.200907	RAV. G7641.200683	RAV. G7641.201010	RAV. G7641.201089	RAV. G7641.200761	RAV. G7645.201232	RAV. G7645.200914	RAV. G7645.200990	RAV. G8645.201249	SFA. GA441.200976	SPA. GA441.201126	SFA. GA441.202000	SPA. GA641.201027	SPA. GA641.201096	SPA. GA641.200952	SPA. GA641.201058	SPA. GA645.200600				
				•																																					
		<b>LISTA DEI COMPONENTI - LIST OF COMPONENTS - TEILELISTE</b> <b>LISTE DES PIÈCES DÉTACHÉES - LISTA DE PIEZAS</b>																		KIT DOTAZIONE ACCESSORY KIT ASSEMBLY AUSSTATTUNGSSET KIT DOTATION KIT DOTACIÓN						▶															
		<b>Tavola N°31C - Rev. 1</b>																								▶	<b>Pag. 205 di 235</b>														



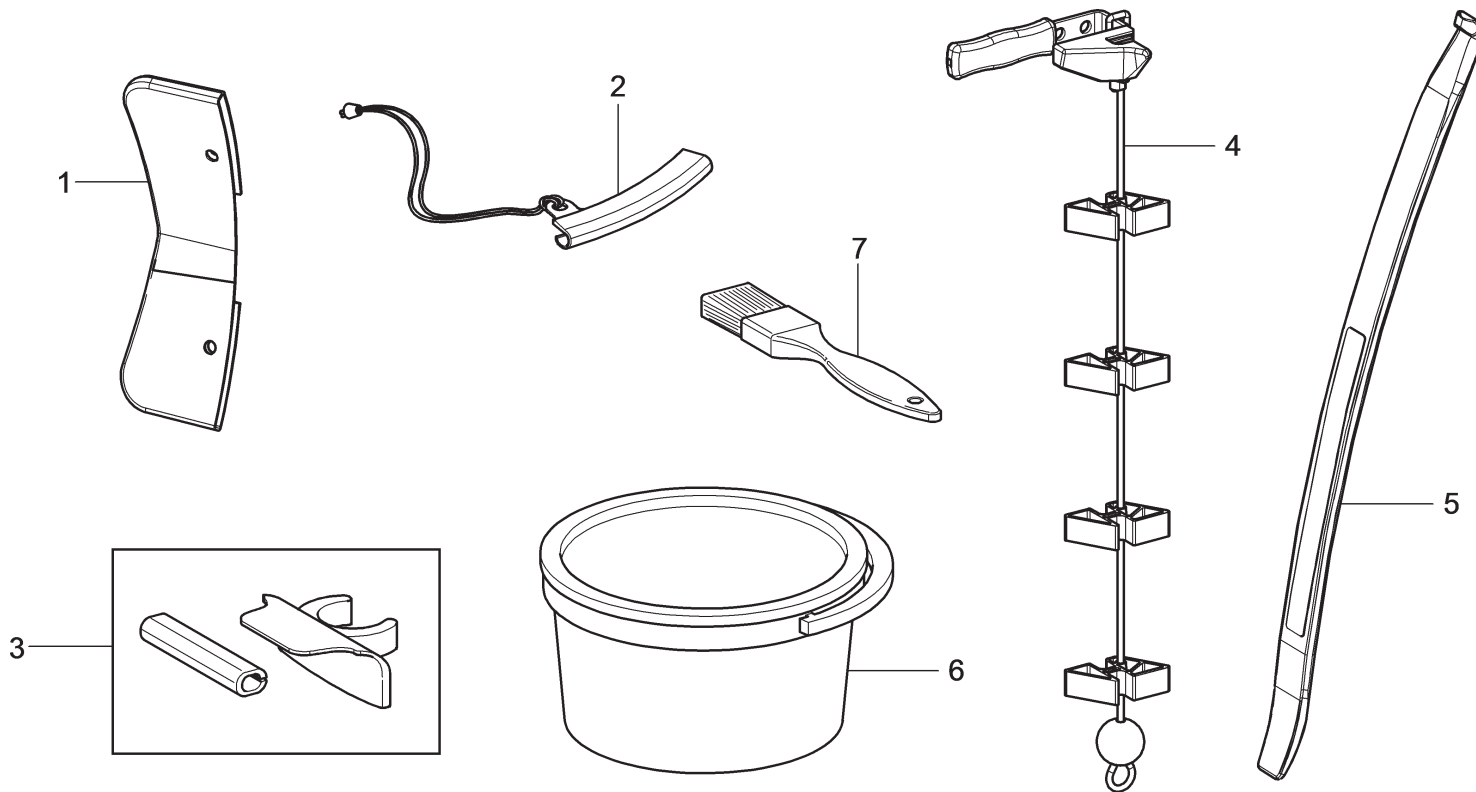



ROT. HP441.201102	ROT. HP641.200838	ROT. HF641.201034	ROT. HP641.200891	ROT. HF641.200785	ROT.HF641.201003 ROT.HF641.201788	ROT. HF641.201072	ROT. HF641.201065	ROT. HF641.201897	ROT.HF643.200894 ROT.HF643.201881	ROT. HF643.201133	ROT. HF643.200983	RAV. G7441.201140	RAV. G7441.200969	RAV. G7441.201119	RAV. G7441.200716	RAV. G7441.200877	RAV. G7441.200821	RAV. G7641.200945	RAV. G7641.200006	RAV. G7641.201041	RAV.G7641.200907 RAV.G7641.200683	RAV. G7641.201010	RAV. G7641.201089	RAV. G7641.200761	RAV. G7645.201232	RAV. G7645.200914	RAV. G7645.200890	RAV. G8645.201249	SFA. GA441.200976	SPA. GA441.201126	SFA. GA441.202000	SPA. GA641.201027	SPA. GA641.201096	SPA. GA641.200952	SPA. GA641.201058	SPA. GA645.200600			
																	●				●																		
		<b>LISTA DEI COMPONENTI - LIST OF COMPONENTS - TEILELISTE</b> <b>LISTE DES PIÈCES DÉTACHÉES - LISTA DE PIEZAS</b>																			<b>KIT DOTAZIONE</b> <b>ACCESSORY KIT ASSEMBLY</b> <b>AUSSTATTUNGSSET</b> <b>KIT DOTATION</b> <b>KIT DOTACIÓN</b>																		
		<b>Tavola N°31D - Rev. 0</b>			<b>730097850</b>															<b>Pag. 207 di 235</b>																			





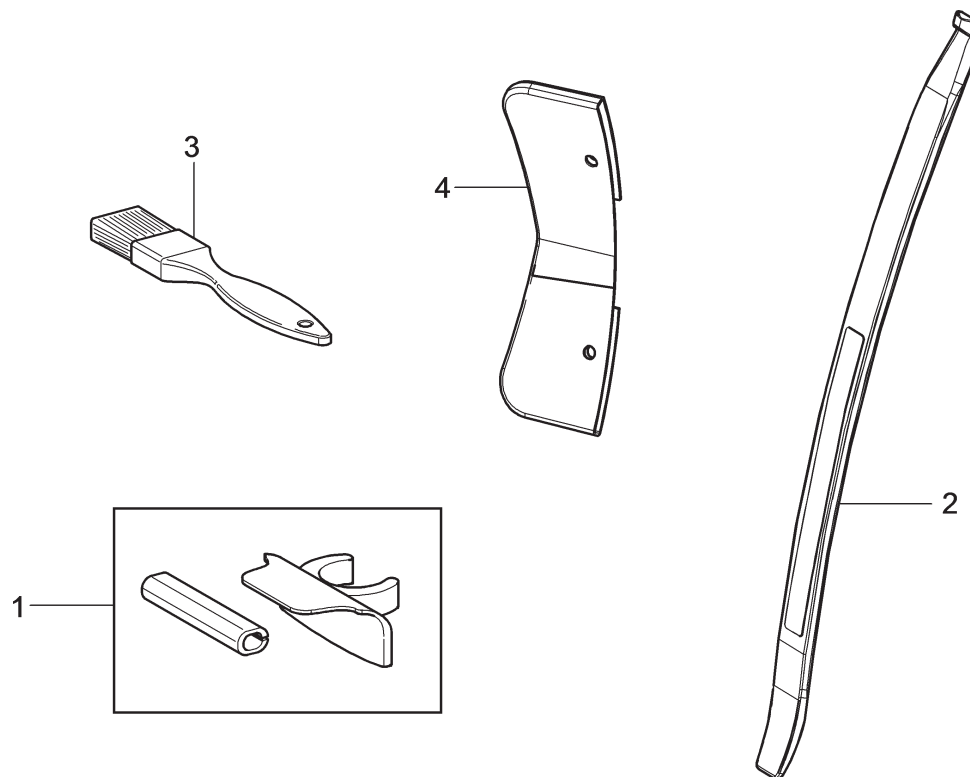





ROT. HP441.201102	ROT. HP641.200838	ROT. HF641.201034	ROT. HP641.200891	ROT. HF641.200785	ROT.HF641.201063 ROT.HF641.201788	ROT. HP641.201072	ROT. HP641.201065	ROT. HP641.201897	ROT.HF643.200884 ROT.HF643.201881	ROT. HP643.201133	ROT. HF643.200983	RAV. G7441.201140	RAV. G7441.200969	RAV. G7441.201119	RAV. G7441.200716	RAV. G7441.200877	RAV. G7441.200821	RAV. G7641.200945	RAV. G7641.200006	RAV. G7641.201041	RAV.G7641.200907 RAV.G7641.200683	RAV. G7641.201010	RAV. G7641.201089	RAV. G7641.200761	RAV. G7645.201232	RAV. G7645.200914	RAV. G7645.200890	RAV. G8645.201249	SFA. GA441.200876	SPA. GA441.201126	SFA. GA441.202000	SPA. GA641.201027	SPA. GA641.201096	SPA. GA641.200952	SPA. GA641.201058	SPA. GA645.200600				
																					<b>LISTA DEI COMPONENTI - LIST OF COMPONENTS - TEILELISTE</b> <b>LISTE DES PIÈCES DÉTACHÉES - LISTA DE PIEZAS</b>										KIT DOTAZIONE ACCESSORY KIT ASSEMBLY AUSSTATTUNGSSET KIT DOTATION KIT DOTACIÓN						▶		<b>Pag. 211 di 235</b>	
																																					▶			
Tavola N°31F - Rev. 0											730098390																													

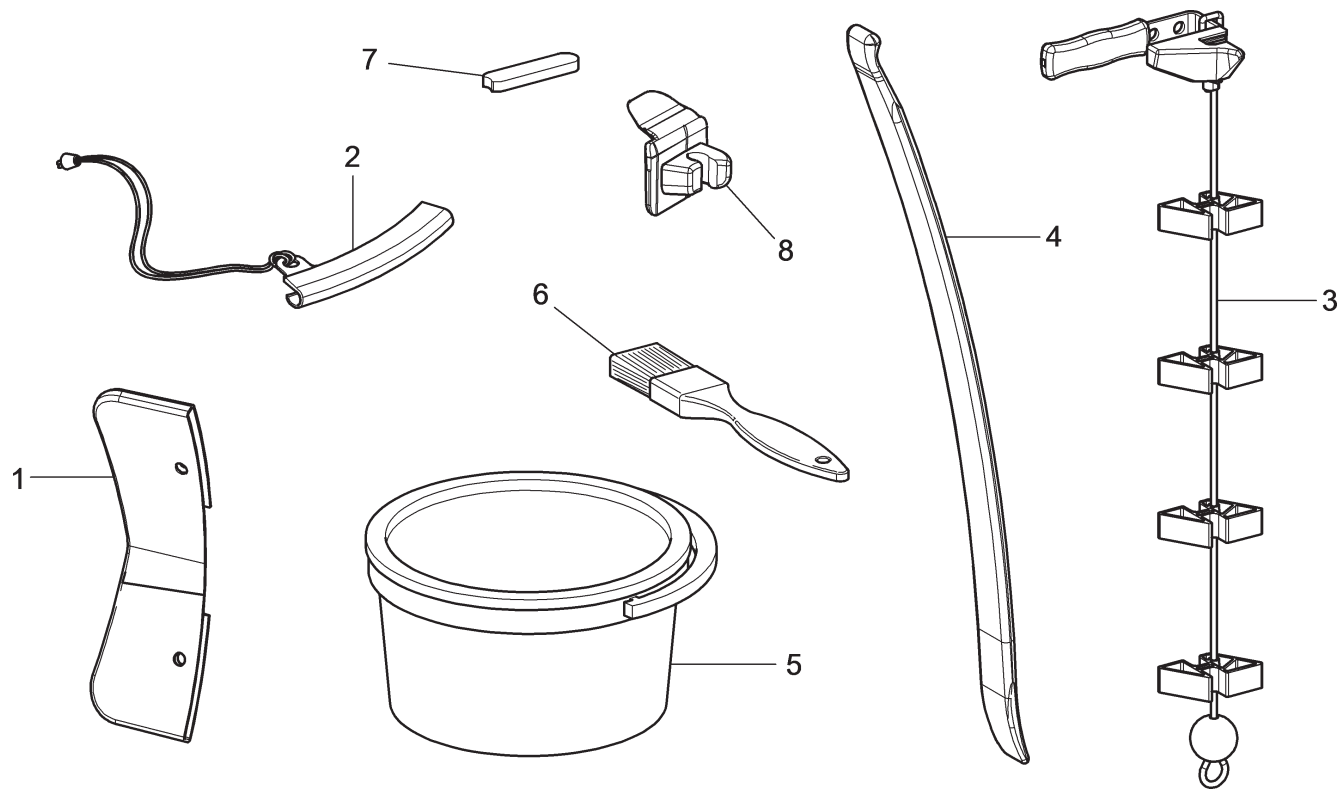



ROT. HP441.201102	ROT. HP641.200838	ROT. HF641.201034	ROT. HP641.200891	ROT. HF641.200785	ROT.HF641.201063 ROT.HF641.201788	ROT. HP641.201072	ROT. HF641.201065	ROT. HP641.201897	ROT.HF643.200894 ROT.HF643.201881	ROT. HP643.201133	ROT. HF643.200983	RAV. G7441.201140	RAV. G7441.200969	RAV. G7441.201119	RAV. G7441.200716	RAV. G7441.200877	RAV. G7441.200821	RAV. G7641.200945	RAV. G7641.200006	RAV. G7641.201041	RAV.G7641.200907 RAV.G7641.200683	RAV. G7641.201010	RAV. G7641.201089	RAV. G7641.200761	RAV. G7645.201232	RAV. G7645.200914	RAV. G7645.200990	RAV. G8645.201249	SFA. GA441.200976	SPA. GA441.201126	SFA. GA441.202000	SPA. GA641.201027	SFA. GA641.201096	SPA. GA641.200952	SPA. GA641.201058	SPA. GA645.200600
<div style="display: flex; justify-content: space-between; align-items: center;"> <div style="text-align: center;">  </div> <div style="text-align: center;"> <p><b>LISTA DEI COMPONENTI - LIST OF COMPONENTS - TEILELISTE</b>  <b>LISTE DES PIÈCES DÉTACHÉES - LISTA DE PIEZAS</b></p> </div> <div style="text-align: center;"> <p>KIT DOTAZIONE  ACCESSORY KIT ASSEMBLY  AUSSTATTUNGSSET  KIT DOTATION  KIT DOTACIÓN</p> </div> <div style="text-align: right;"> <p><b>T</b> →  → <b>T</b></p> </div> </div>																																				
<b>Tavola N°31G - Rev. 0</b>												<b>730098980</b>																<b>Pag. 213 di 235</b>								



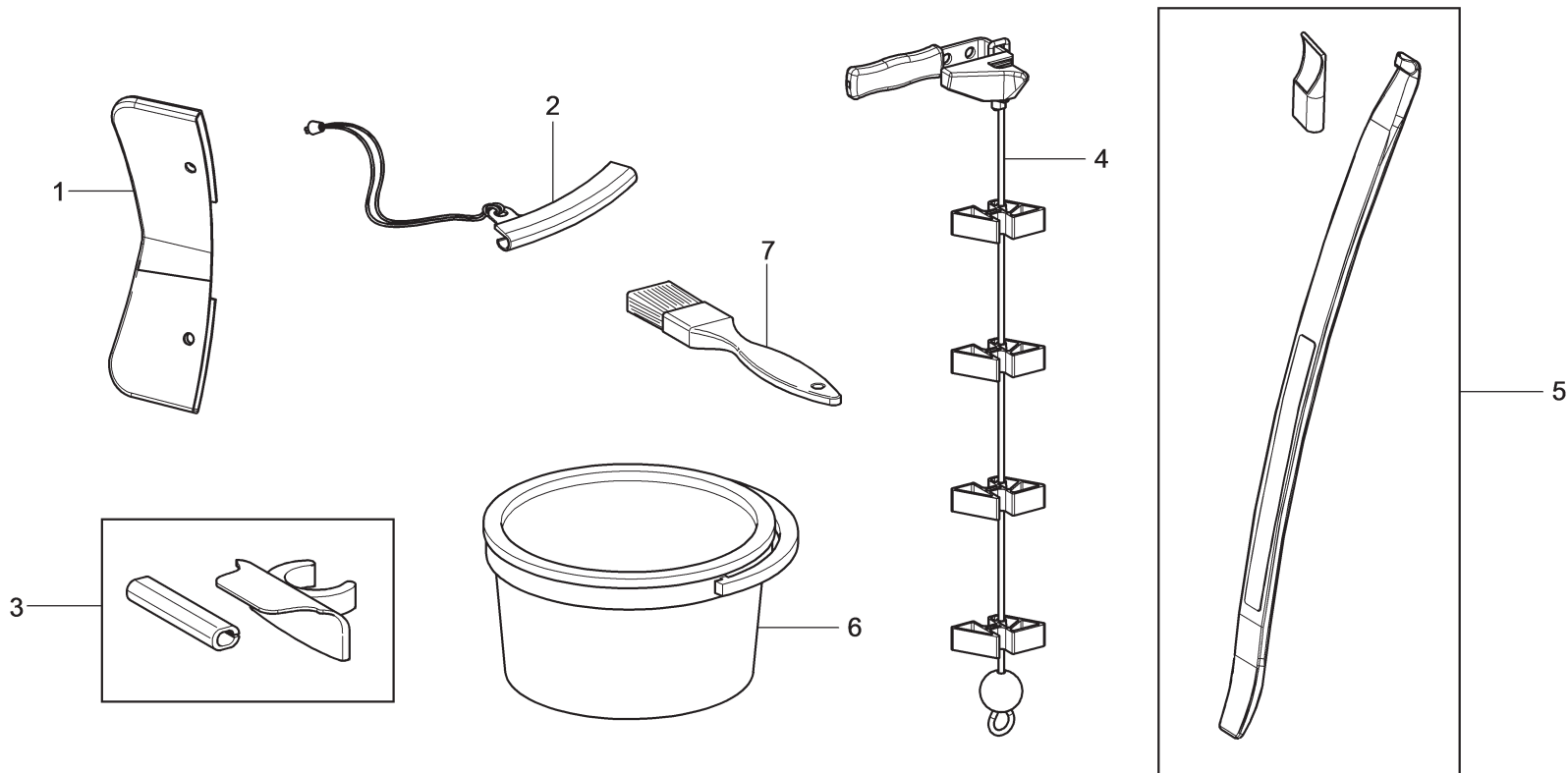



ROT. HP441.201102	ROT. HP641.200838	ROT. HF641.201034	ROT. HP641.200891	ROT. HP641.200785	ROT.HP641.201003 ROT.HP641.201788	ROT. HP641.201072	ROT. HP641.201065	ROT. HP641.201897	ROT.HP643.200894 ROT.HP643.201881	ROT. HP643.201133	ROT. HP643.200983	RAV. G7441.201140	RAV. G7441.200969	RAV. G7441.200716	RAV. G7441.201119	RAV. G7441.200877	RAV. G7441.200821	RAV. G7641.200945	RAV. G7641.200006	RAV. G7641.201041	RAV.G7641.200907 RAV.G7641.200683	RAV. G7641.201010	RAV. G7641.201089	RAV. G7641.200761	RAV. G7645.201232	RAV. G7645.200914	RAV. G7645.200890	RAV. G8645.201249	SFA. GA441.200876	SFA. GA441.201126	SFA. GA441.202000	SFA. GA641.201027	SFA. GA641.201096	SFA. GA641.200952	SFA. GA641.201058	SFA. GA645.200600				
																				●																				
				<b>LISTA DEI COMPONENTI - LIST OF COMPONENTS - TEILELISTE</b> <b>LISTE DES PIÈCES DÉTACHÉES - LISTA DE PIEZAS</b>																KIT DOTAZIONE ACCESSORY KIT ASSEMBLY AUSSTATTUNGSSET KIT DOTATION KIT DOTACIÓN										▶										
				Tavola N°31H - Rev. 0										730099950																				▶						
																				<b>Pag. 215 di 235</b>																				

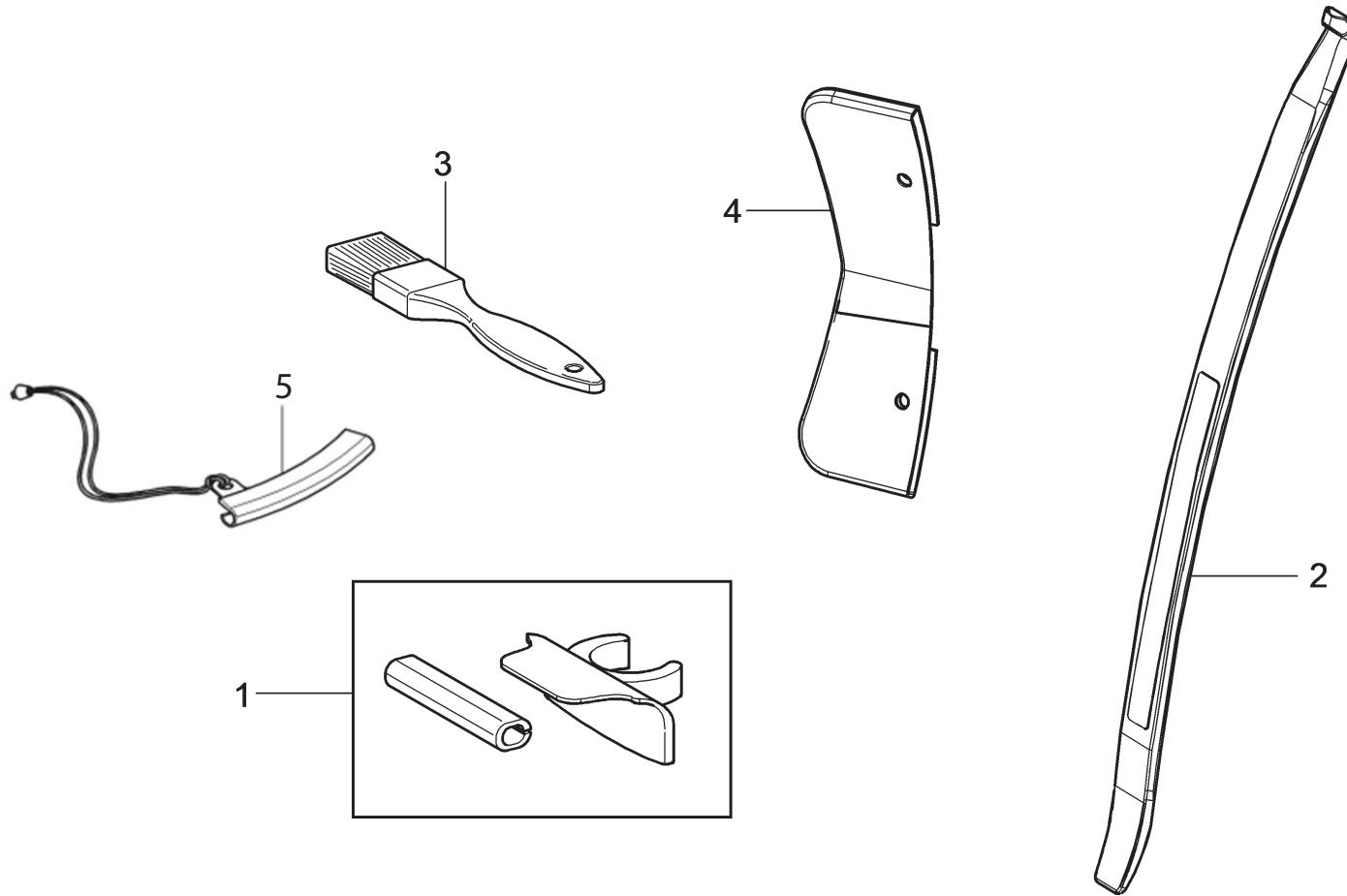



ROT. HP441.201102	ROT. HP641.200838	ROT. HP641.201034	ROT. HP641.200891	ROT. HP641.200785	ROT:HP641.201063 ROT:HP641.201788	ROT. HP641.201072	ROT. HP641.201065	ROT. HP641.201897	ROT:HP643.200684 ROT:HP643.201881	ROT. HP643.201133	ROT. HP643.200983	RAV. G7441.201140	RAV. G7441.200969	RAV. G7441.201119	RAV. G7441.200716	RAV. G7441.200877	RAV. G7441.200821	RAV. G7641.200945	RAV. G7641.200006	RAV. G7641.201041	RAV:G7641.200907 RAV:G7641.200683	RAV. G7641.201010	RAV. G7641.201089	RAV. G7641.200761	RAV. G7645.201232	RAV. G7645.200914	RAV. G7645.200890	RAV. G8645.201249	SFA. GA441.200976	SPA. GA441.201126	SFA. GA441.202000	SPA. GA641.201027	SPA. GA641.201096	SPA. GA641.200952	SPA. GA641.201058	SPA. GA645.200600					
				<b>LISTA DEI COMPONENTI - LIST OF COMPONENTS - TEILELISTE</b> <b>LISTE DES PIÈCES DÉTACHÉES - LISTA DE PIEZAS</b>																KIT DOTAZIONE ACCESSORY KIT ASSEMBLY AUSSTATTUNGSSET KIT DOTATION KIT DOTACIÓ										 											
				<b>Tavola N°31I-Rev.0</b>									<b>730190590</b>									<b>Pag. 217 di 235</b>																			



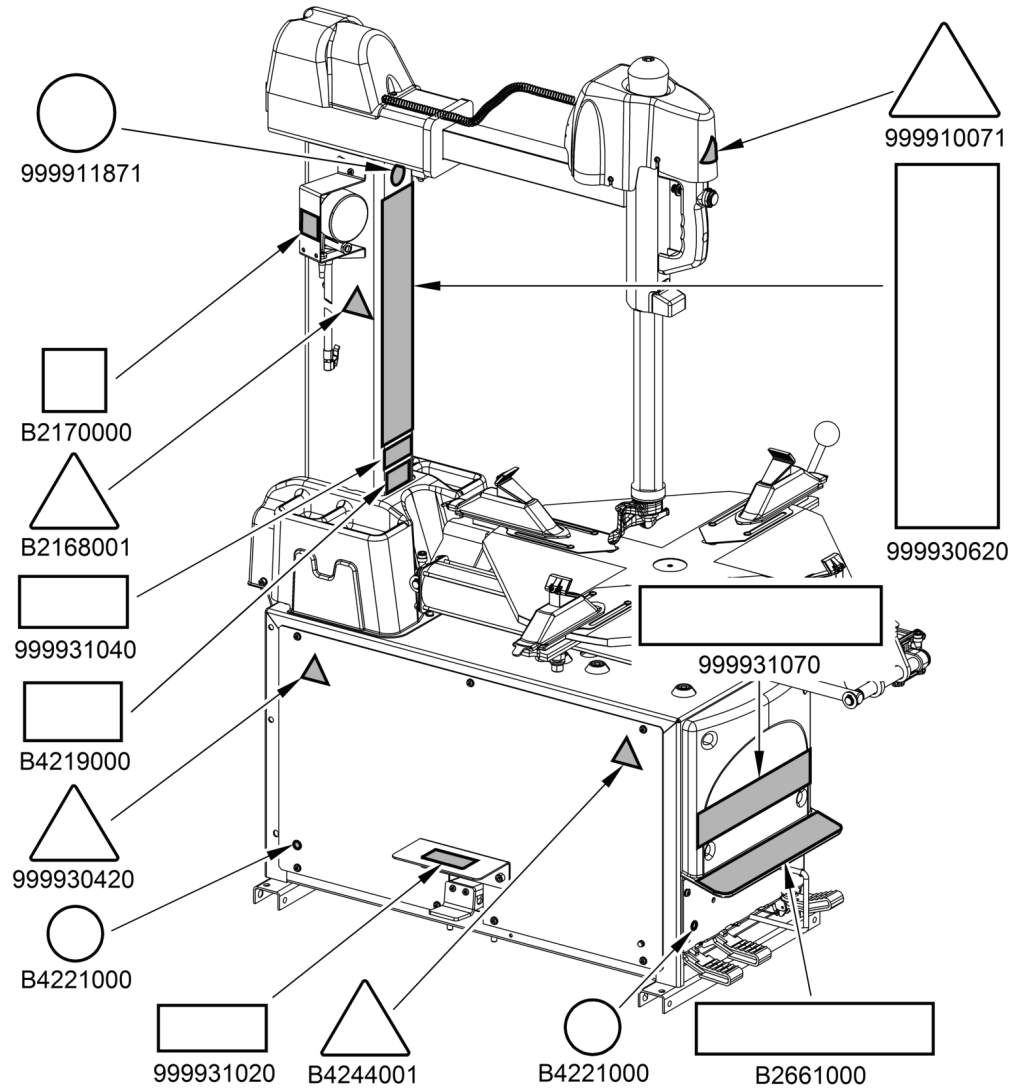
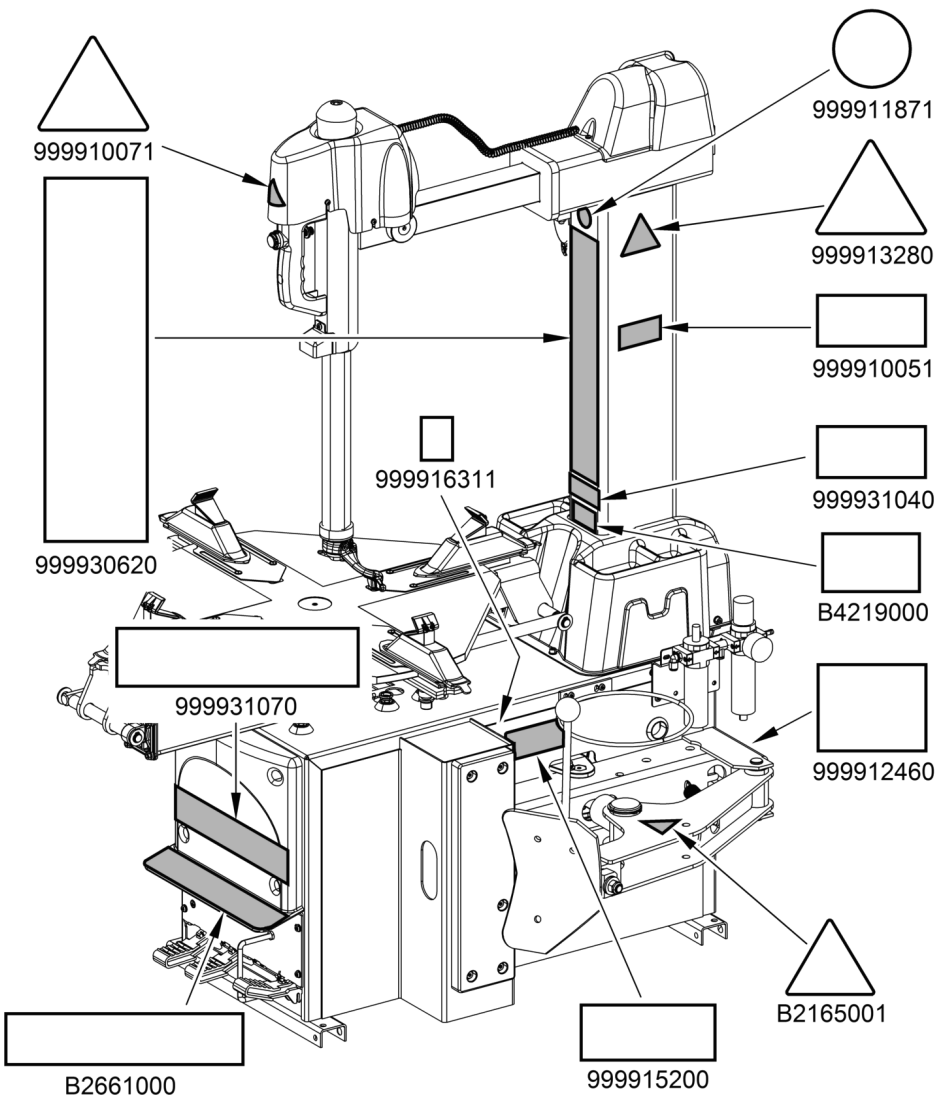

ROT. HP441.201102	ROT. HP641.200838	ROT. HP641.201034	ROT. HP641.200891	ROT. HP641.200785	ROT. HP641.201003	ROT. HP641.201788	ROT. HP641.201072	ROT. HP641.201065	ROT. HP641.201897	ROT. HP643.200894	ROT. HP643.201881	ROT. HP643.201133	ROT. HP643.200983	RAV. G7441.201140	RAV. G7441.200969	RAV. G7441.201119	RAV. G7441.200716	RAV. G7441.200877	RAV. G7441.200821	RAV. G7641.200945	RAV. G7641.200006	RAV. G7641.201041	RAV. G7641.200907	RAV. G7641.200683	RAV. G7641.201010	RAV. G7641.201089	RAV. G7641.200761	RAV. G7645.201232	RAV. G7645.200914	RAV. G7645.200990	RAV. G8645.201249	SPA. GA441.200976	SPA. GA441.201126	SPA. GA441.202000	SPA. GA641.201027	SPA. GA641.201096	SPA. GA641.200952	SPA. GA641.201058	SPA. GA645.200600
-------------------	-------------------	-------------------	-------------------	-------------------	-------------------	-------------------	-------------------	-------------------	-------------------	-------------------	-------------------	-------------------	-------------------	-------------------	-------------------	-------------------	-------------------	-------------------	-------------------	-------------------	-------------------	-------------------	-------------------	-------------------	-------------------	-------------------	-------------------	-------------------	-------------------	-------------------	-------------------	-------------------	-------------------	-------------------	-------------------	-------------------	-------------------	-------------------	-------------------



**LISTA DEI COMPONENTI - LIST OF COMPONENTS - TEILELISTE**  
**LISTE DES PIECES DETACHEES - LISTA DE PIEZAS**

**Tavola N°32A - Rev. 0**

POSIZIONAMENTO TARGHETTE  
NAMEPLATES POSITIONING  
SCHILDPOSITIONIERUNG  
POSITIONNEMENT PLAQUETTES  
POSICIONAMIENTO PLAQUITAS

▶  
▶  
**Pag. 219 di 235**

Tavola N°32A - Rev. 0

-

ROT. HP441.201102	ROT. HP641.200938	ROT. HP641.201034	ROT. HP641.200891	ROT. HP641.200785	ROT/HP641.201003	ROT/HP641.201788	ROT. HP641.201072	ROT. HP641.201065	ROT. HP641.201997	ROT/HP643.200984	ROT/HP643.201681	ROT. HP643.201133	ROT. HP643.200983	RAV G7441.201140	RAV G7441.200969	RAV G7441.201119	RAV G7441.200716	RAV G7441.200877	RAV G7441.200921	RAV G7641.200945	RAV G7641.200006	RAV G7641.201041	RAV/G7641.200907	RAV/G7641.200689	RAV G7641.201010	RAV G7641.201089	RAV G7641.200761	RAV G7645.201232	RAV G7645.200914	RAV G7645.200990	RAV G8645.201249	SFA GA441.200976	SFA GA441.201126	SFA GA441.202000	SFA GA641.201027	SFA GA641.201096	SFA GA641.200952	SFA GA641.201058	SFA GA645.200600					
●																																												
#		D.R	N	Descrizione	Description	Beschreibung	Description	Descripción																																				

	✓		B2165001	Targhetta pericolo stallonatore laterale	Lateral bead breaker danger nameplate	Seitenabdrückersgefahrenschild	Plaquette danger décolle-pneus latéral	Plaquita peligro destalonador lateral				
	✓		B2168001	Targhetta pericolo scoppio pneumatico	Tyre burst danger indicating nameplate	Gefahrenschild von Reifenbersten	Plaquette danger éclatement pneu	Plaquita peligro de explosión del neumático				
	✓		B2170000	Targhetta indicazione max. pressione gonfiaggio (per i modelli con manometro di gonfiaggio)	Max. inflation pressure rating nameplate (applies to models with inflation pressure gauge)	Anzeigeschild des Höchstaufpumpendrucks (für Modelle mit Aufpumpenmanometer)	Plaquette indication max. pression gonflage (Pour les modèles avec manomètre de gonflage)	Plaquita indicación máx. presión inflado (para modelos con manómetro de inflado)				
	✓		B2661000	Targhetta simboli 4 pedali	4-pedals symbol nameplate	Schild Symbole 4 Pedalen	Plaquette symboles 4 pédales	Plaquita símbolos 4 pedales				
	✓		B4219000	Targhetta senso di rotazione	Rotation indicating nameplate	Drehrichtungsschild	Plaquette rotation moteur	Plaquita sentido de rotación				
	✓		B4221000	Targhetta messa a terra	Grounding nameplate	Erdungsschild	Plaquette mise à la terre	Plaquita puesta a tierra				
	✓		B4244001	Targhetta pericolo parti rotanti	Rotating parts danger nameplate	Gefahrenschild für drehenden Teilen	Plaquette danger parties en rotation	Plaquita peligro partes giratorias				
	✓		999910051	Targhetta uso dispositivi di protezione	Protection device use nameplate	Verwendung von Schutzeinrichtungen Schild	Plaquette utilisation dispositifs de protection	Plaquita uso disp. protección				
	✓		999910071	Targhetta pericolo testina	Head danger indicating nameplate	Kopf-Gefahrenschild	Plaquette danger tête	Plaquita peligro cabezal				
	✓		999911871	Targhetta cuffie	Headset nameplate	Kopfhörerschild	Plaquette cache-oreilles	Plaquita cascos				
	✓		999912460	Targhetta pressione alimentazione	Supply pressure indicating nameplate	Versorgungsdruckschild	Plaquette pression alimentation	Plaquita presión alimentación				
	✓		999913280	Targhetta ribaltopalo	Post tilting nameplate	Kippen der Stange Schild	Plaquette basculement poteau	Plaquita vuelco palo				
	✓		999915200	Targhetta matricola	Serial number nameplate	Seriennummernschild	Plaquette matricule	Plaquita matrícula				
	✓		999916311	Targhetta cassonetto rifiuti	Rubbish skip nameplate	Abfalltonneschild	Plaquette poubelle déchets	Plaquita contenedor desechos				
	✓		999930420	Targhetta pericolo scossa elettrica	Electric shock danger nameplate	Elektrizitätgefahrenschild	Plaquette danger électricité	Plaquita peligro choque eléctrico				
	✓		999930620	Targhetta logo Rotary	Rotary logo nameplate	Rotary-Logo Schild	Plaquette logo Rotary	Plaquita logotipo Rotary				
	✓		999931020	Targhetta pedale di gonfiaggio no GT	Inflation pedal no Inflation Unit nameplate	Aufpumppedalschild ohne Tubeless-Aufpumpersystem	Plaquette pédale de gonflage pas gonflage Tubeless	Plaquita pedal de inflado no inflado Tubeless				
	✓		999931040	Targhetta "Engineered by Butler"	"Engineered by Butler" nameplate	"Engineered by Butler" Schild	Plaquette "Engineered by Butler"	Plaquita "Engineered by Butler"				
	✓		999931070	Targhetta apparecchiatura	Equipment nameplate	Geräteschild	Plaquette équipement	Plaquita equipo				

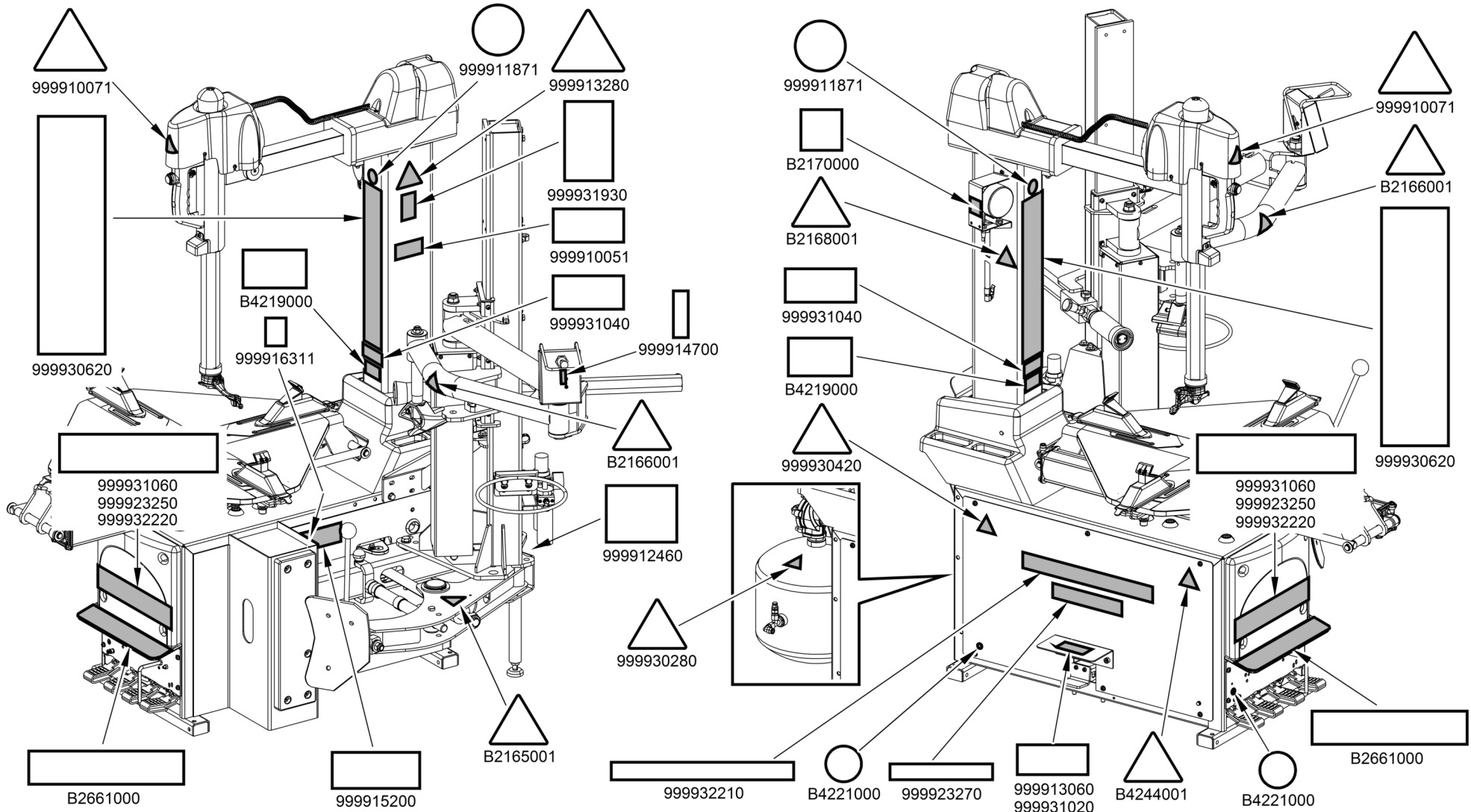

ROT. HP441.201102	ROT. HP641.200838	ROT. HP641.201034	ROT. HP641.200891	ROT. HP641.200785	ROT/HP641.201003	ROT/HP641.201788	ROT. HP641.201072	ROT. HP641.201065	ROT. HP641.201897	ROT/HP643.200894	ROT/HP643.201881	ROT. HP643.201133	ROT. HP643.200983	RAV. G7441.201140	RAV. G7441.200969	RAV. G7441.201119	RAV. G7441.200716	RAV. G7441.200877	RAV. G7441.200821	RAV. G7641.200945	RAV. G7641.200006	RAV. G7641.201041	RAV/G7641.200907	RAV/G7641.200683	RAV. G7641.201010	RAV. G7641.201089	RAV. G7641.200761	RAV. G7645.201232	RAV. G7645.200914	RAV. G7645.200990	RAV. G8645.201249	SPA. GA441.200976	SPA. GA441.201126	SPA. GA441.202000	SPA. GA641.201027	SPA. GA641.201096	SPA. GA641.200952	SPA. GA641.201058	SPA. GA645.200600									
	•	•	•	•	•		•	•	•																																							







**LISTA DEI COMPONENTI - LIST OF COMPONENTS - TEILELISTE**  
**LISTE DES PIÈCES DÉTACHÉES - LISTA DE PIEZAS**

**Tavola N°32B - Rev. 2**

-





POSIZIONAMENTO TARGHETTE  
NAMEPLATES POSITIONING  
SCHILDERPOSITIONIERUNG  
POSITIONNEMENT PLAQUETTES  
POSICIONAMIENTO PLAQUITAS

		<b>LISTA DEI COMPONENTI - LIST OF COMPONENTS - TEILELISTE</b> <b>LISTE DES PIÈCES DÉTACHÉES - LISTA DE PIEZAS</b>										POSIZIONAMENTO TARGHETTE NAMEPLATES POSITIONING SCHILDERPOSITIONIERUNG POSITIONNEMENT PLAQUETTES POSICIONAMIENTO PLAQUITAS						<b>Pag. 222 di 235</b>																						
		<b>Tavola N°32B - Rev. 2</b>					-																																	
ROT. HP441.201102	ROT. HP641.200938	ROT. HP641.201034	ROT. HP641.200891	ROT. HP641.200785	ROT. HP641.201003	ROT. HP641.201788	ROT. HP641.201072	ROT. HP641.201065	ROT. HP641.201997	ROT. HP643.200984	ROT. HP643.201681	ROT. HP643.201133	ROT. HP643.200983	RAV G7441.201140	RAV G7441.200969	RAV G7441.201119	RAV G7441.200716	RAV G7441.200877	RAV G7441.200921	RAV G7641.200945	RAV G7641.200006	RAV G7641.201041	RAV G7641.200907	RAV G7641.200689	RAV G7641.201010	RAV G7641.201089	RAV G7641.200761	RAV G7645.201232	RAV G7645.200914	RAV G7645.200990	RAV G8645.201249	SFA GA441.200976	SFA GA441.201126	SFA GA441.202000	SFA GA641.201027	SFA GA641.201096	SFA GA641.200952	SFA GA641.201058	SFA GA645.200600	
	•	•	•	•	•	•	•	•	•																															
#		D.R	N	Descrizione	Description	Beschreibung	Description	Descripción																																

	✓		B2165001	Targhetta pericolo stallonatore laterale	Lateral bead breaker danger nameplate	Seitenabdrückersgefahrenschild	Plaquette danger décolle-pneus latéral	Plaquita peligro destalonador lateral		
	✓		B2166001	Targhetta pericolo stallonatore (per i modelli con dispositivo premi-alza tallone pneumatico)	Bead breaker danger nameplate (applies to models pneumatic bead press-lift device)	Abdrückersgefahrenschild (für Modelle mit pneumatischer Wulstabdruck-Hubvorrichtung)	Plaquette danger décolle-pneus (pour les modèles avec dispositif pousse-lève talon pneumatique)	Plaquita peligro destalonador (para modelos equipados con dispositivo presiona-levanta talón neumático)		
	✓		B2168001	Targhetta pericolo scoppio pneumatico	Tyre burst danger indicating nameplate	Gefahrenschild von Reifenbersten	Plaquette danger éclatement pneu	Plaquita peligro de explosión del neumático		
	✓		B2170000	Targhetta indicazione max. pressione gonfiaggio	Max. inflation pressure rating nameplate	Anzeigeschild des Höchstaufpumpendrucks	Plaquette indication maximum pression gonflage	Plaquita indicación máx. presión inflado		
	✓		B2661000	Targhetta simboli 4 pedali	4-pedals symbol nameplate	Schild Symbole 4 Pedalen	Plaquette symboles 4 pédales	Plaquita símbolos 4 pedales		
	✓		B4219000	Targhetta senso di rotazione	Rotation indicating nameplate	Drehrichtungschild	Plaquette rotation moteur	Plaquita sentido de rotación		
	✓		B4221000	Targhetta messa a terra	Grounding nameplate	Erdungsschild	Plaquette mise à la terre	Plaquita puesta a tierra		
	✓		B4244001	Targhetta pericolo parti rotanti	Rotating parts danger nameplate	Gefahrenschild für drehenden Teilen	Plaquette danger parties en rotation	Plaquita peligro partes giratorias		
	✓		999910051	Targhetta uso dispositivi di protezione	Protection device use nameplate	Verwendung von Schutzvorrichtungen Schild	Plaquette utilisation dispositifs de protection	Plaquita uso disp. protección		
	✓		999910071	Targhetta pericolo testina	Head danger indicating nameplate	Kopf-Gefahrenschild	Plaquette danger tête	Plaquita peligro cabezal		
	✓		999911871	Targhetta cuffie	Headset nameplate	Kopfhörerschild	Plaquette cache-oreilles	Plaquita cascos		
	✓		999912460	Targhetta pressione alimentazione	Supply pressure indicating nameplate	Versorgungsdruckschild	Plaquette pression alimentation	Plaquita presión alimentación		
	✓		999913060	Targhetta pedale gonfiatubeless (per i modelli con sistema gonfiatubeless)	Tubeless inflation pedal nameplate (applies to models with system tubeless inflation)	Pedal Tubeless-Aufpumper Schild (für die Modelle mit Aufpumpersystem)	Plaquette pédale gonflage tubeless (pour les modèles avec système gonflage tubeless)	Plaquita pedal inflado tubeless (para los modelos con sistema inflado tubeless)		
	✓		999913280	Targhetta ribaltopalo	Post tilting nameplate	Kippen der Stange Schild	Plaquette basculement poteau	Plaquita vuelco palo		
	✓		999914700	Targhetta comandi premitalone (per i modelli con dispositivo premi-alza tallone pneumatico)	Bead press control nameplate (applies to models with pneumatic bead press-lift device)	Wulstabdrücksschild (für Modelle mit pneumatischer Wulstabdruck-Hubvorrichtung)	Plaquette commandes pousse-talon (pour les modèles avec dispositif pousse-lève talon pneumatique)	Plaquita mandos presionatalón (para modelos equipados con dispositivo presiona-levanta talón neumático)		
	✓		999915200	Targhetta matricola	Serial number nameplate	Seriennummernschild	Plaquette matricule	Plaquita matrícula		
	✓		999916311	Targhetta cassonetto rifiuti	Rubbish skip nameplate	Abfalltonneschild	Plaquette poubelle déchets	Plaquita contenedor desechos		
	✓		999931930	Targhetta WDK (per i modelli con dispositivo premi-alza tallone pneumatico)	WDK nameplate (on models with pneumatic bead press-lift device)	WDK-Schild (für Modelle mit pneumatischer Wulstabdruck-Hubvorrichtung)	Plaquette WDK (pour les modèles avec dispositif pousse-lève talon pneumatique)	Plaquita WDK (para modelos equipados con dispositivo presiona-levanta talón neumático)		
	✓		999923250	Targhetta Primetool (solo per il modello TC624 EASY)	Primetool nameplate (TC624 EASY model only)	Primetool-Schild (nur für TC624 EASY Modell)	Plaquette Primetool (seulement pour le modèle TC624 EASY)	Plaquita Primetool (sólo para el modelo TC624 EASY)		







		<b>LISTA DEI COMPONENTI - LIST OF COMPONENTS - TEILELISTE</b> <b>LISTE DES PIÈCES DÉTACHÉES - LISTA DE PIEZAS</b>										POSIZIONAMENTO TARGHETTE NAMEPLATES POSITIONING SCHILDERPOSITIONIERUNG POSITIONNEMENT PLAQUETTES POSICIONAMIENTO PLAQUITAS										<b>Pag. 225 di 235</b>																					
		<b>Tavola N°32C - Rev. 2</b>					-					 																															
ROT. HP441.201102	ROT. HP641.200938	ROT. HP641.201034	ROT. HP641.200891	ROT. HP641.200785	ROT. HP641.201003	ROT. HP641.201788	ROT. HP641.201072	ROT. HP641.201065	ROT. HP641.201997	ROT. HP643.200984	ROT. HP643.201681	ROT. HP643.201133	ROT. HP643.200983	RAV G7441.201140	RAV G7441.200969	RAV G7441.201119	RAV G7441.200716	RAV G7441.200877	RAV G7441.200921	RAV G7641.200945	RAV G7641.200006	RAV G7641.201041	RAV G7641.200907	RAV G7641.200689	RAV G7641.201010	RAV G7641.201089	RAV G7641.200761	RAV G7645.201232	RAV G7645.200914	RAV G7645.200990	RAV G8645.201249	SFA GA441.200976	SFA GA441.201126	SFA GA441.202000	SFA GA641.201027	SFA GA641.201096	SFA GA641.200952	SFA GA641.201058	SFA GA645.200600				
#		D.R	N	Descrizione	Description	Beschreibung	Description	Descripción																																			

	✓		B2165001	Targhetta pericolo stallonatore laterale	Lateral bead breaker danger nameplate	Seitenabdrückersgefahrenschild	Plaquette danger décolle-pneus latéral	Plaquita peligro destalonador lateral		
	✓		B2166001	Targhetta pericolo stallonatore	Bead breaker danger nameplate	Abdrückersgefahrenschild	Plaquette danger décolle-pneus	Plaquita peligro destalonador		
	✓		B2168001	Targhetta pericolo scoppio pneumatico	Tyre burst danger indicating nameplate	Gefahrenschild von Reifenbersten	Plaquette danger éclatement pneu	Plaquita peligro de explosión del neumático		
	✓		B2170000	Targhetta indicazione max. pressione gonfiaggio	Max. inflation pressure rating nameplate	Anzeigeschild des Höchstaufpumpendrucks	Plaquette indication maximum pression gonflage	Plaquita indicación máx. presión inflado		
	✓		B4219000	Targhetta senso di rotazione	Rotation indicating nameplate	Drehrichtungsschild	Plaquette rotation moteur	Plaquita sentido de rotación		
	✓		B4221000	Targhetta messa a terra	Grounding nameplate	Erdungsschild	Plaquette mise à la terre	Plaquita puesta a tierra		
	✓		B4244001	Targhetta pericolo parti rotanti	Rotating parts danger nameplate	Gefahrenschild für drehenden Teilen	Plaquette danger parties en rotation	Plaquita peligro partes giratorias		
	✓		999910051	Targhetta uso dispositivi di protezione	Protection device use nameplate	Verwendung von Schutzvorrichtungen Schild	Plaquette utilisation dispositifs de protection	Plaquita uso disp. protección		
	✓		999910071	Targhetta pericolo testina	Head danger indicating nameplate	Kopf-Gefahrenschild	Plaquette danger tête	Plaquita peligro cabezal		
	✓		999911871	Targhetta cuffie	Headset nameplate	Kopfhörerschild	Plaquette cache-oreilles	Plaquita cascos		
	✓		999912460	Targhetta pressione alimentazione	Supply pressure indicating nameplate	Versorgungsdruckschild	Plaquette pression alimentation	Plaquita presión alimentación		
	✓		999913060	Targhetta pedale gonfiatubeless (per i modelli con sistema gonfiatubeless)	Tubeless inflation pedal nameplate (applies to models with system tubeless inflation)	Pedal Tubeless-Aufpumper Schild (für die Modelle mit Aufpumpersystem)	Plaquette pédale gonflage tubeless (pour les modèles avec système gonflage tubeless)	Plaquita pedal inflado tubeless (para los modelos con sistema inflado tubeless)		
	✓		999913280	Targhetta ribaltopalo	Post tilting nameplate	Kippen der Stange Schild	Plaquette basculement poteau	Plaquita vuelco palo		
	✓		999914700	Targhetta comandi premiallone	Bead press device control nameplate	Wulstabdrücksschild	Plaquette commandes pousse-talon	Plaquita mandos presionatalón		
	✓		999915200	Targhetta matricola	Serial number nameplate	Seriennummernschild	Plaquette matricule	Plaquita matrícula		
	✓		999916311	Targhetta cassonetto rifiuti	Rubbish skip nameplate	Abfalltonneschild	Plaquette poubelle déchets	Plaquita contenedor desechos		
	✓		999921010	Targhetta pedaliera 5 pedali	5-pedals pedalboard nameplate	Schild Pedalsteuerung mit 5 Pedalen	Plaquette pédalier à 5 pédales	Plaquita pedalera de 5 pedales		
	✓		999931940	Targhetta WDK	WDK nameplate	Schild WDK	Plaquette WDK	Plaquita WDK		
	✓		999930280	Targhetta pericolo recipiente in pressione (per i modelli con sistema gonfiatubeless)	Pressure vessel danger nameplate (applies to with system tubeless inflation)	Gefahrenschild für Druckbehälter (für die Modelle mit Aufpumpersystem)	Plaquette danger réservoir sous pression (pour les modèles avec système gonflage tubeless)	Plaquita peligro recipiente de presión (para los modelos con sistema inflado tubeless)		
	✓		999930420	Targhetta pericolo scossa elettrica	Electric shock danger nameplate	Elektrizitätgefahrenschild	Plaquette danger électricité	Plaquita peligro choque eléctrico		
	✓		999930620	Targhetta logo Rotary	Rotary logo nameplate	Rotary-Logo Schild	Plaquette logo Rotary	Plaquita logotipo Rotary		
	✓		999931010	Targhetta apparecchiatura	Equipment nameplate	Geräteschild	Plaquette équipement	Plaquita equipo		





**Tavola N°32D - Rev. 0**

#		D.R	N	Descrizione	Description	Beschreibung	Description	Descripción		
---	---	-----	---	-------------	-------------	--------------	-------------	-------------	---	---

✓			B2165001	Targhetta pericolo stallonatore laterale	Lateral bead breaker danger nameplate	Seitenabdrückersgefahrenschild	Plaquette danger décolle-pneus latéral	Plaquita peligro destalonador lateral		
✓			B2166001	Targhetta pericolo stallonatore (per i modelli con dispositivo premi-alza tallone pneumatico)	Bead breaker danger nameplate (applies to models pneumatic bead press-lift device)	Abdrückersgefahrenschild (für Modelle mit pneumatischer Wulstabdruck-Hubvorrichtung)	Plaquette danger décolle-pneus (pour les modèles avec dispositif pousse-lève talon pneumatique)	Plaquita peligro destalonador (para modelos equipados con dispositivo presiona-levanta talón neumático)		
✓			B2168001	Targhetta pericolo scoppio pneumatico	Tyre burst danger indicating nameplate	Gefahrenschild von Reifenbersten	Plaquette danger éclatement pneu	Plaquita peligro de explosión del neumático		
✓			B2170000	Targhetta indicazione max. pressione gonfiaggio (per i modelli con manometro di gonfiaggio)	Max. inflation pressure rating nameplate (applies to models with inflation pressure gauge)	Anzeigeschild des Höchstaufpumpendrucks (für Modelle mit Aufpumpenmanometer)	Plaquette indication max. pression gonflage (pour les modèles avec manomètre de gonflage)	Plaquita indicación máx. presión inflado (para modelos con manómetro de inflado)		
✓			B2661000	Targhetta simboli 4 pedali (per i modelli con manometro di gonfiaggio)	4-pedals symbol nameplate (applies to models with inflation pressure gauge)	4 Pedale Symbolschild (für Modelle mit Aufpumpenmanometer)	Plaquette symboles 4 pédales (pour les modèles avec manomètre de gonflage)	Plaquita símbolos 4 pedales (para modelos con manómetro de inflado)		
✓			B4219000	Targhetta senso di rotazione	Rotation indicating nameplate	Drehrichtungsschild	Plaquette rotation moteur	Plaquita sentido de rotación		
✓			B4221000	Targhetta messa a terra	Grounding nameplate	Erdungsschild	Plaquette mise à la terre	Plaquita puesta a tierra		
✓			B4244001	Targhetta pericolo parti rotanti	Rotating parts danger nameplate	Gefahrenschild für drehenden Teilen	Plaquette danger parties en rotation	Plaquita peligro partes giratorias		
✓			999910051	Targhetta uso dispositivi di protezione	Protection device use nameplate	Verwendung von Schutzvorrichtungen Schild	Plaquette utilisation dispositifs de protection	Plaquita uso disp. protección		
✓			999910071	Targhetta pericolo testina	Head danger indicating nameplate	Kopf-Gefahrenschild	Plaquette danger tête	Plaquita peligro cabezal		
✓			999911460	Targhetta matricola (per i modelli serie GA2441)	Serial number nameplate (applies to GA2441 series models)	Schild Seriennummer (für Modelle der GA2441-Serie)	Plaquette matricule (pour les modèles série GA2441)	Plaquita matrícula (para modelos serie GA2441)		
✓			999911871	Targhetta cuffie	Headset nameplate	Kopfhörerschild	Plaquette cache-oreilles	Plaquita cascos		
✓			999911910	Targhetta pedali (per i modelli senza manometro di gonfiaggio)	Pedal nameplate (applies to models without inflation pressure gauge)	Pedalschild (für Modelle ohne Aufpumpenmanometer)	Plaquette pédales (pour les modèles sans manomètre de gonflage)	Plaquita pedales (para modelos sin manómetro de inflado)		
✓			999912400	Targhetta matricola (per i modelli serie G7441)	Serial number nameplate (applies to G7441 series models)	Schild Seriennummer (für Modelle der G7441-Serie)	Plaquette matricule (pour les modèles série G7441)	Plaquita matrícula (para modelos serie G7441)		
✓			999912460	Targhetta pressione alimentazione	Supply pressure indicating nameplate	Versorgungsdruckschild	Plaquette pression alimentation	Plaquita presión alimentación		
✓			999913060	Targhetta pedale gonfiatubeless (per i modelli con sistema gonfiatubeless)	Tubeless inflation pedal nameplate (applies to models with system tubeless inflation)	Pedal Tubeless-Aufpumper Schild (für die Modelle mit Aufpumpersystem)	Plaquette pédale gonflage tubeless (pour les modèles avec système gonflage tubeless)	Plaquita pedal inflado tubeless (para los modelos con sistema inflado tubeless)		
✓			999913280	Targhetta ribaltopalo	Post tilting nameplate	Kippen der Stange Schild	Plaquette basculement poteau	Plaquita vuelco palo		



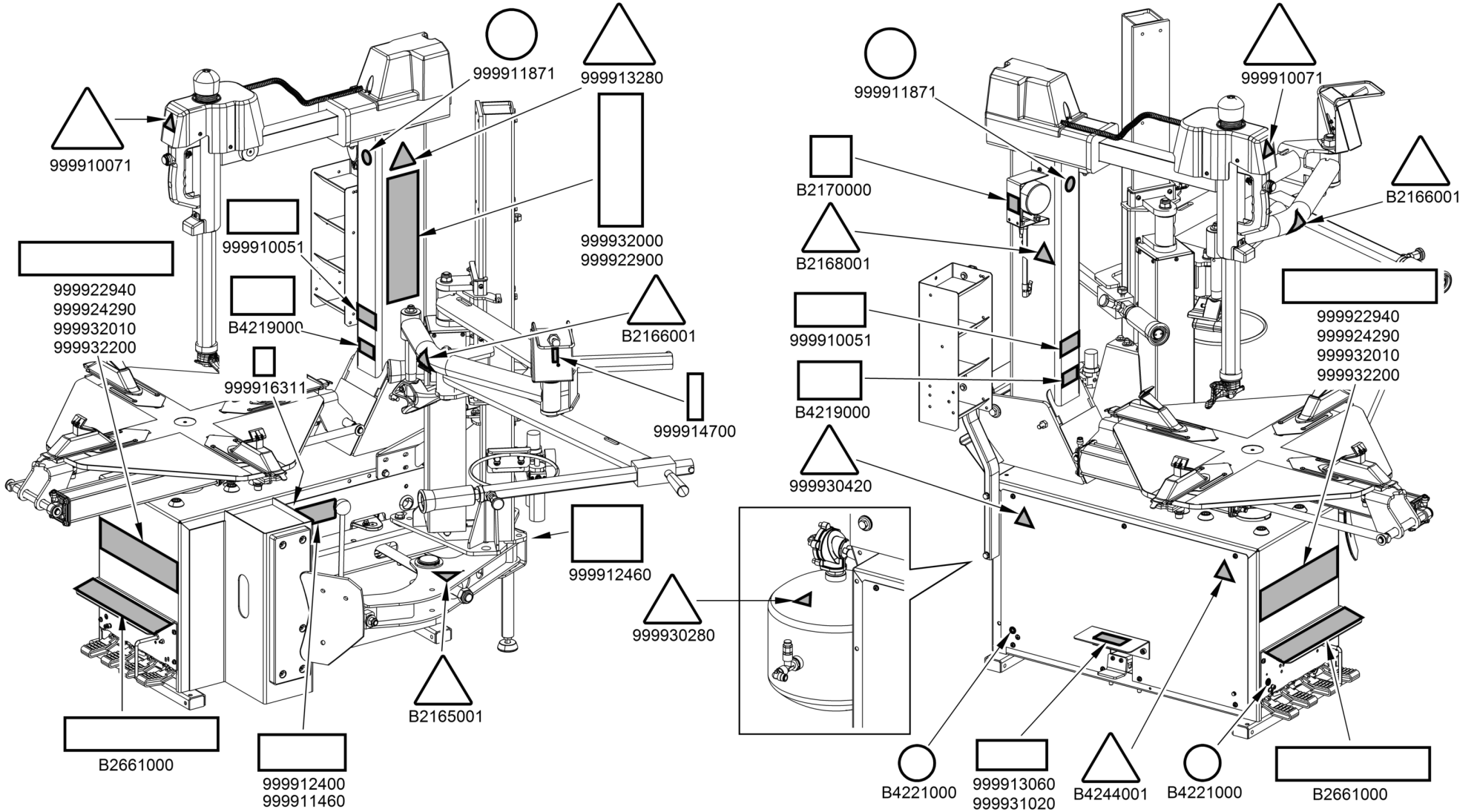

ROT. HP441.201102	ROT. HP641.200838	ROT. HP641.201034	ROT. HP641.200891	ROT. HP641.200785	ROT.HP641.201003	ROT.HP641.201788	ROT. HP641.201072	ROT. HP641.201065	ROT. HP641.201897	ROT.HP643.200894	ROT.HP643.201881	ROT. HP643.201133	ROT. HP643.200983	RAV. G7441.201140	RAV. G7441.200969	RAV. G7441.201119	RAV. G7441.200716	RAV. G7441.200877	RAV. G7441.200821	RAV. G7641.200945	RAV. G7641.200006	RAV. G7641.201041	RAV.G7641.200907	RAV.G7641.200683	RAV. G7641.201010	RAV. G7641.201089	RAV. G7641.200761	RAV. G7645.201232	RAV. G7645.200914	RAV. G7645.200990	RAV. G8645.201249	SPA. GA441.200976	SPA. GA441.201126	SPA. GA441.202000	SPA. GA641.201027	SPA. GA641.201096	SPA. GA641.200952	SPA. GA641.201058	SPA. GA645.200600			
																				•	•	•	•	•	•	•	•	•	•	•	•	•	•	•	•	•	•	•	•	•	•	•



**LISTA DEI COMPONENTI - LIST OF COMPONENTS - TEILELISTE**  
**LISTE DES PIÈCES DÉTACHÉES - LISTA DE PIEZAS**

**Tavola N°32E - Rev. 2**

POSIZIONAMENTO TARGHETTE  
 NAMEPLATES POSITIONING  
 SCHILDERPOSITIONIERUNG  
 POSITIONNEMENT PLAQUETTES  
 POSICIONAMIENTO PLAQUITAS

