



7102-M035-01

**TYRE-CHANGER SERIES
CLASSIC - COMBI - G1001 - G1065**

INSTRUCTION MANUAL
Applicable to the following models

ROT.CLASS.201713

ROT.CLASS.200440

ROT.COMBI.201706

ROT.COMBI.200525

RAV.G1001.200815

RAV.G1065.200792

EN

TRANSLATION OF THE
ORIGINAL INSTRUCTIONS

For spare parts drawings refer to the document "LIST OF COMPONENTS" to be requested from the manufacturer.

- For any further information please contact your local dealer or call:

VEHICLE SERVICE GROUP ITALY S.r.l

Via Filippo Brunelleschi, 9 - 44020 Ostellato - Ferrara - Italy

Phone (+39) 051 6781511 - Fax (+39) 051 846349 - e-mail: aftersales.emea@vsgdover.com

7102-M035-01 - Rev. n. 02 (08/2025)

SUMMARY

GENERAL DESCRIPTION (ROT.CLASS.201713 - ROT.CLASS.200440 - RAV.G1001.200815)	5	10.0 ELECTRICAL CONNECTIONS	26
GENERAL DESCRIPTION (ROT.COMBI.201706 - ROT.COMBI.200525)	6	11.0 CONTROLS	27
GENERAL DESCRIPTION (RAV.G1065.200792)	7	11.1 <i>Bead press device control unit (standard on some models)</i>	27
SYMBOLS USED IN THE MANUAL	8	11.2 <i>Pedalboard (applies to models with self-centring chuck)</i>	27
PLATE LOCATION DRAWING (ROT.CLASS.201713 - ROT.CLASS.200440 - RAV.G1001.200815)	9	11.3 <i>Inflation pedal (standard on some models)</i>	28
PLATE LOCATION DRAWING (ROT.COMBI.201706 - ROT.COMBI.200525)	11	11.4 <i>Tool arm control (standard on some models)</i>	28
PLATES LOCATION DRAWING (RAV.G1065.200792)	13	11.5 <i>Bead breaker control unit (applies to models with upper and lower bead breaker)</i>	29
1.0 GENERAL INTRODUCTION	15	11.6 <i>3-pedal pedalboard (applies to model with flat chuck)</i>	29
1.1 <i>Introduction</i>	15	12.0 USE OF THE EQUIPMENT	30
2.0 INTENDED USE	15	12.1 <i>Precaution measures during tyre removal and fitting</i>	30
2.1 <i>Training of personnel</i>	15	12.2 <i>Preliminary operations - Preparing the wheel</i>	32
3.0 SAFETY DEVICES	16	12.3 <i>Use of mounting strap with stopper (applies to models with belt kit as- sembly)</i>	32
3.1 <i>Residual risks</i>	16	12.4 <i>Bead breaking with side shovel</i>	33
4.0 IMPORTANT SAFETY INSTRUCTIONS	17	12.5 <i>Wheel clamping (applies to models with self-centring chuck)</i>	34
4.1 <i>General safety rules</i>	17	12.6 <i>Wheel clamping (applies to model with flat chuck)</i>	34
5.0 PACKING AND MOBILIZATION FOR TRANSPORT	18	12.6.1 <i>Chuck height adjustment (ap- plies to model with flat chuck)</i>	37
6.0 UNPACKING	19	12.6.2 <i>Reverse wheel pan protection (applies to model with flat chuck)</i>	37
7.0 MOBILIZATION	19	12.7 <i>Bead breaking by means of vertical rollers (applies to models with upper and lower bead breaker)</i>	38
8.0 WORKING ENVIRONMENT CONDITIONS	20	12.8 <i>Tyre disassembly (applies to models with bead press device)</i>	39
8.1 <i>Work position</i>	20	12.9 <i>Tyre disassembly (applies to models with upper and lower bead breaker)</i>	41
8.2 <i>Working area</i>	21	12.10 <i>Demounting the tyre upper bead with the force multiplier (standard on some models)</i>	43
8.3 <i>Lighting</i>	21	12.11 <i>Tyre mounting (applies to models with bead press device)</i>	44
9.0 ASSEMBLY AND PREPARATION FOR USE	21	12.12 <i>Tyre assembly (applies to models with upper and lower bead breaker)</i>	45
9.1 <i>Anchoring system</i>	21	12.13 <i>Mounting the tyre upper bead with the beadpusher with pulling system (standard on some models)</i>	46
9.2 <i>Assembly procedures</i>	22	12.14 <i>For rims with spoke end raised com- pared to the rim-edge</i>	47
9.3 <i>Connection to the compressed air supply</i>	25		



**12.15 Special use of the upper and lower
 bead breaker (standard on some
 models) _____ 47**
12.16 Inflation _____ 48
12.16.1 Tyre inflation _____ 48
13.0 ROUTINE MAINTENANCE _____ 49
14.0 TROUBLESHOOTING TABLE _____ 50
15.0 TECHNICAL DATA _____ 52
15.1 Technical electrical data _____ 52
15.2 Technical mechanical data _____ 52
15.3 Dimensions _____ 53
16.0 STORING _____ 56
17.0 SCRAPPING _____ 56
18.0 REGISTRATION PLATE DATA _____ 56

19.0 FUNCTIONAL DIAGRAMS _____ 56
**Drawing A - Wiring diagram (applies to
 models ROT.CLASS.201713 -
 ROT.CLASS.200440 -
 RAV.G1001.200815) _____ 57**
**Drawing B - Wiring diagram (applies to
 ROT.COMBI.201706 -
 ROT.COMBI.200525 models) _____ 59**
**Drawing C - Wiring diagram (applies to
 RAV.G1065.200792 model) _____ 61**
**Drawing D - Pneumatic diagram (applies to
 ROT.CLASS.201713 -
 ROT.CLASS.200440 -
 RAV.G1001.200815 models) _____ 63**
**Drawing E - Pneumatic diagram (applies to
 ROT.COMBI.201706 -
 ROT.COMBI.200525 models) _____ 64**
**Drawing F - Pneumatic diagram (applies to
 RAV.G1065.200792 model) _____ 67**

**CONTENT OF THE EC DECLARATION OF
 CONFORMITY _____ 70**

**CONTENT OF THE UK DECLARATION OF
 CONFORMITY _____ 71**

Features	Model					
	ROT.CLASS.201713	ROT.CLASS.200440	ROT.COMBI.201706	ROT.COMBI.200525	RAV.G1001.200815	RAV.G1065.200792
Self-centring chuck	•	•	•	•	•	
Flat chuck						•
Upper and lower bead breaker			•	•		•
Inflation pressure gauge	•	•	•	•		•
Inflation gun					•	
Bead press device	•	•			•	
Force multiplier						•
Pedalboard for self-centring chuck	•	•	•	•	•	
Pedalboard for flat chuck						•
Inflation pedal	•	•	•	•		•
Tool arm control			•	•		•
Upper bead breaker clamping control			•	•		•
Tool box	•	•	•	•		•
Bead breaker shovel guard	•	•		•	•	•
Roller with support	•	•			•	
Mirror with magnetic support			•	•		•
Two-faced cone						•
Reverse wheels protection						•
Locking device						•
Bead protection foils						•
Beadpusher with pulling system		•		•		•
Bead protection kit + 50 bead sliding foils		•		•		
Stroke limiter		•		•		
Bead protector		•		•		•
Belt kit assembly				•		•
WDK certification		•		•		•

• = standard

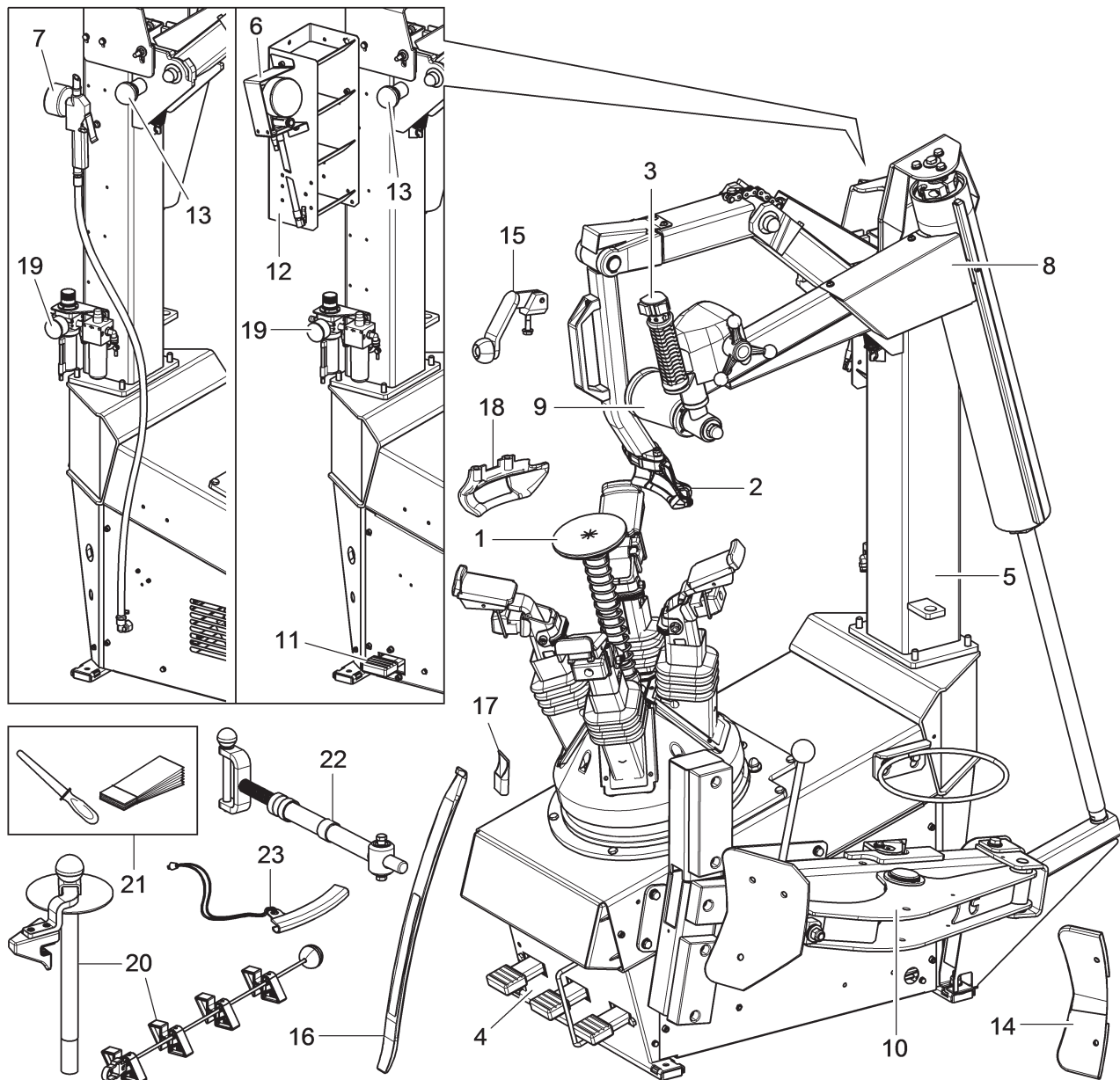
**GENERAL DESCRIPTION (ROT.CLASS.201713 - ROT.CLASS.200440 - Fig. 1
RAVG1001.200815)**

KEY

- | | |
|---|--|
| 1 - Self-centring chuck | 13 - Arm-lock side control |
| 2 - Toolhead | 14 - Bead breaker shovel guard |
| 3 - Bead press device control unit | 15 - Roller with support |
| 4 - Pedalboard | 16 - Bead lifting lever |
| 5 - Column | 17 - Lever protection |
| 6 - Inflation pressure gauge (standard on one model) | 18 - Rimsled, mobile insert |
| 7 - Inflation gun (standard on one model) | 19 - Filter assembly |
| 8 - Bead press device | 20 - Beadpusher with pulling system (standard on one model) |
| 9 - Bead press roller | 21 - Bead protection kit + 50 bead sliding foils (standard on one model) |
| 10 - Lateral bead breaker | 22 - Stroke limiter (standard on one model) |
| 11 - Inflation pedal (applies to model with inflation pressure gauge) | 23 - Bead protector (standard on one model) |
| 12 - Tool box (standard on one model) | |

GENERAL DESCRIPTION (ROT.COMBI.201706 - ROT.COMBI.200525)

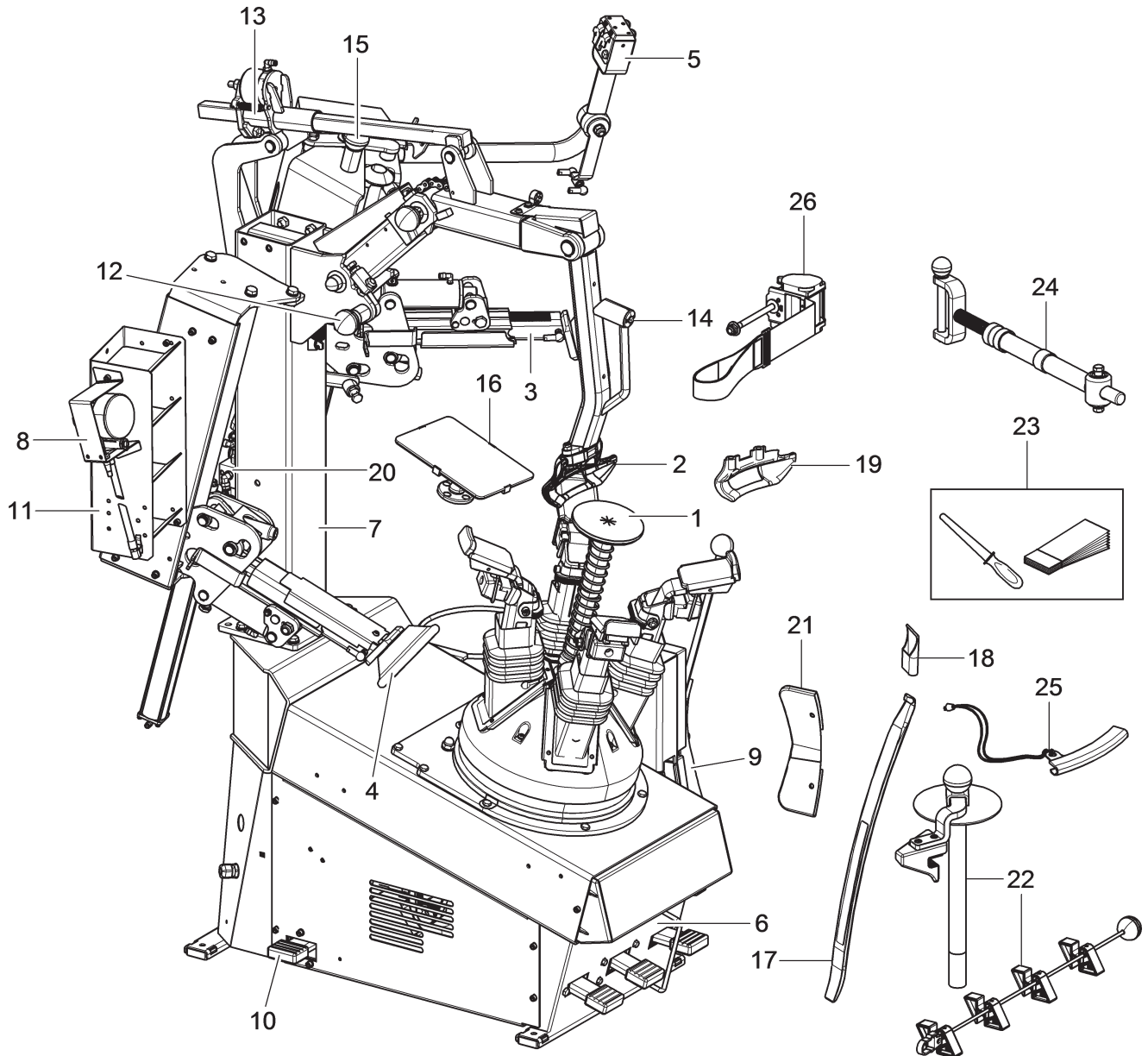
Fig. 2



KEY

- | | |
|--|--|
| 1 - Self-centring chuck | 18 - Lever protection |
| 2 - Toolhead | 19 - Rimsled, mobile insert |
| 3 - Upper bead breaker | 20 - Filter assembly |
| 4 - Lower bead breaker | 21 - Bead breaker shovel guard (standard on one model) |
| 5 - Control unit | 22 - Beadpusher with pulling system (standard on one model) |
| 6 - Pedalboard | 23 - Bead protection kit + 50 bead sliding foils (standard on one model) |
| 7 - Column | 24 - Stroke limiter (standard on one model) |
| 8 - Inflation pressure gauge | 25 - Bead protector (standard on one model) |
| 9 - Lateral bead breaker | 26 - Belt kit assembly (standard on one model) |
| 10 - Inflation pedal | |
| 11 - Tool box | |
| 12 - Arm-lock side control | |
| 13 - Tool arm locking device | |
| 14 - Tool arm unlock push button | |
| 15 - Upper bead breaker clamping control | |
| 16 - Mirror with magnetic support | |
| 17 - Bead lifting lever | |

GENERAL DESCRIPTION (RAV.G1065.200792)



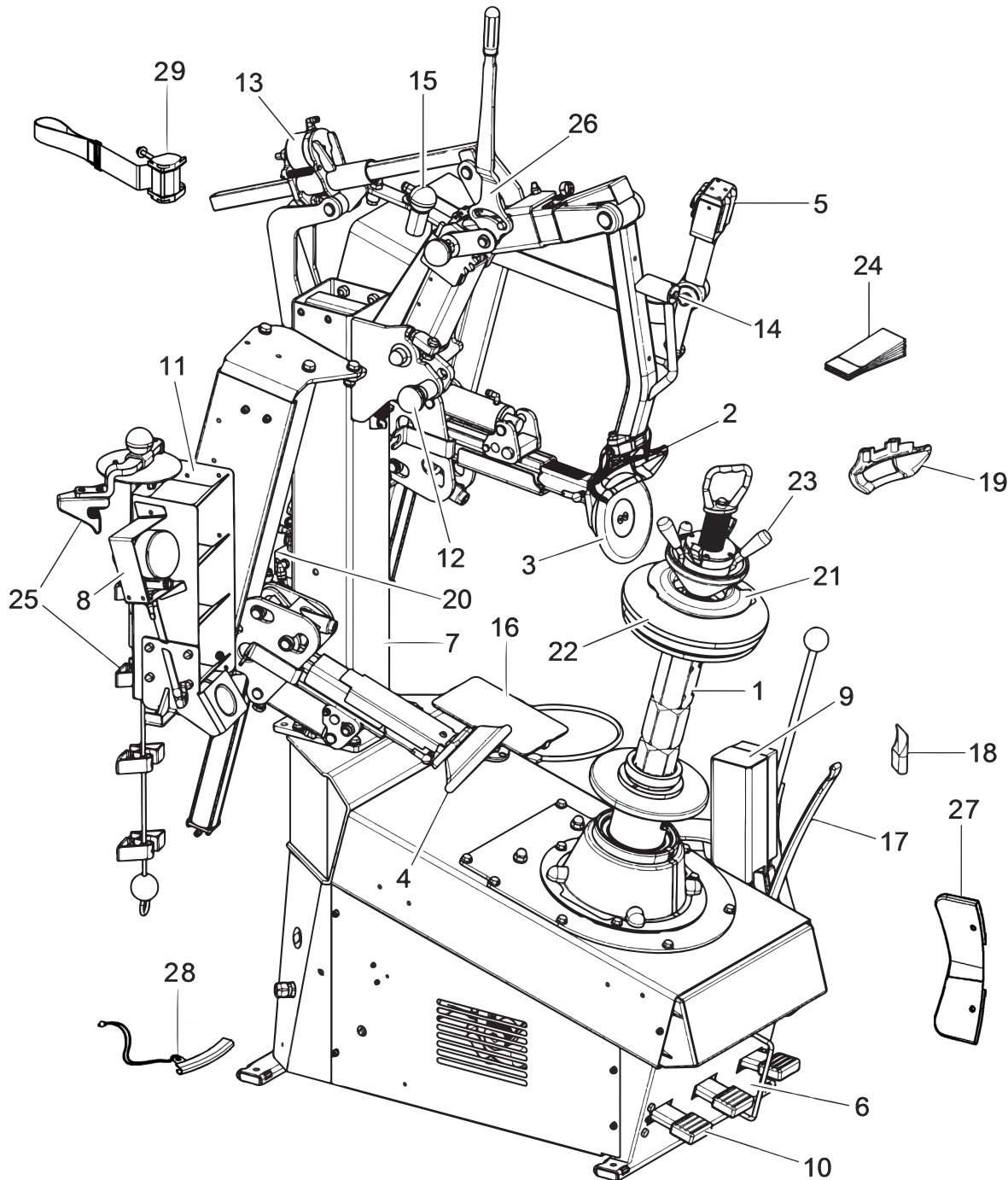



Fig. 3







KEY

- | | |
|--|-------------------------------------|
| 1 - Flat chuck | 16 - Mirror with magnetic support |
| 2 - Toolhead | 17 - Bead lifting lever |
| 3 - Upper bead breaker | 18 - Lever protection |
| 4 - Lower bead breaker | 19 - Rimsled, mobile insert |
| 5 - Control unit | 20 - Filter assembly |
| 6 - Pedalboard | 21 - Two-faced cone |
| 7 - Column | 22 - Reverse wheels protection |
| 8 - Inflation pressure gauge | 23 - Locking device |
| 9 - Lateral bead breaker | 24 - Bead protection foils |
| 10 - Inflation pedal | 25 - Beadpusher with pulling system |
| 11 - Tool box | 26 - Force multiplier |
| 12 - Arm-lock side control | 27 - Bead breaker shovel guard |
| 13 - Tool arm locking device | 28 - Bead protector |
| 14 - Tool arm unlock push button | 29 - Belt Kit Assembly |
| 15 - Upper bead breaker clamping control | |

SYMBOLS USED IN THE MANUAL

Symbols	Description
	Read instruction manual.
	Wear work gloves.
	Wear work shoes.
	Wear safety goggles.
	Mandatory. Operations or jobs to be performed compulsorily.
	Warning. Be particularly careful (possible material damages).

Symbols	Description
	Danger! Be particularly careful.
	Note. Indication and/or useful information.
	Move with fork lift truck or pallet truck.
	Lift from above.
	Technical assistance necessary. Do not perform any maintenance.

**PLATE LOCATION DRAWING
 (ROT.CLASS.201713 - ROT.CLASS.200440 - RAV.G1001.200815)**

Fig. 4

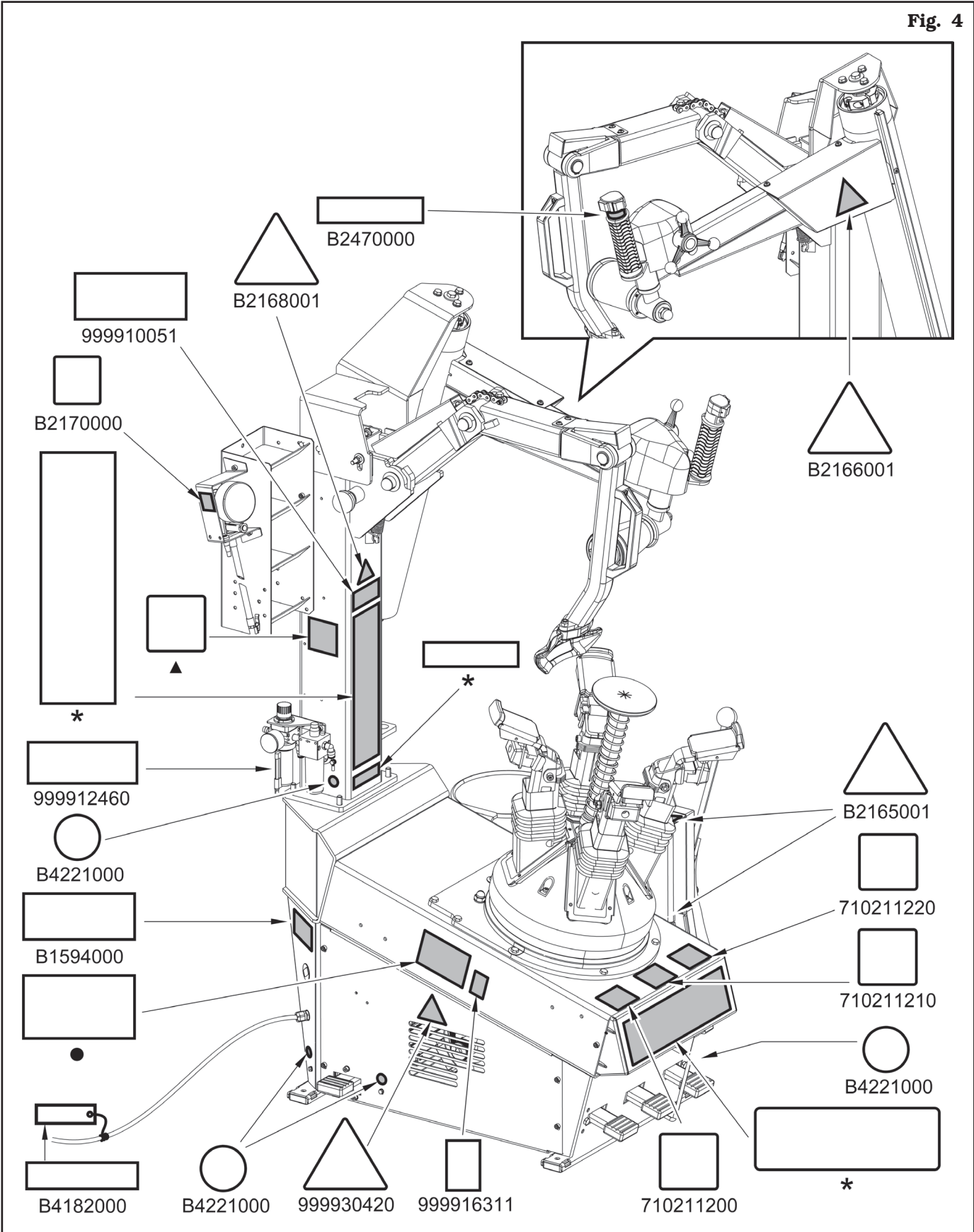

Code numbers of nameplates

B1594000	<i>Date indicating nameplate</i>
B2165001	<i>Lateral bead breaker danger nameplate</i>
B2166001	<i>Bead breaker danger nameplate</i>
B2168001	<i>Tyre burst danger indicating nameplate</i>
B2170000	<i>Max. inflation pressure rating nameplate (applies to model with inflation pressure gauge)</i>
B2470000	<i>Push-button nameplate</i>
B4182000	<i>Electric motor specifications nameplate</i>
B4221000	<i>Grounding nameplate</i>
710211200	<i>Self-centring chuck opening/closing nameplate</i>
710211210	<i>Rotation direction nameplate</i>
710211220	<i>Bead breaking control nameplate</i>
999910051	<i>Protection device use nameplate</i>
999912460	<i>Supply pressure indicating nameplate</i>
999916311	<i>Rubbish skip nameplate</i>
999930420	<i>Electric shock danger nameplate</i>
▲	<i>WDK nameplate (applies to model with WDK certification)</i>
●	<i>Serial number nameplate</i>
*	<i>Manufacturer or machine name nameplate</i>



IF ONE OR MORE NAMEPLATES ARE MISSING FROM THE EQUIPMENT OR BECOMES DIFFICULT TO READ. REPLACE IT AND QUOTE ITS/THEIR PART NUMBER/S WHEN REORDERING.

**PLATE LOCATION DRAWING
 (ROT.COMBI.201706 - ROT.COMBI.200525)**

Fig. 5

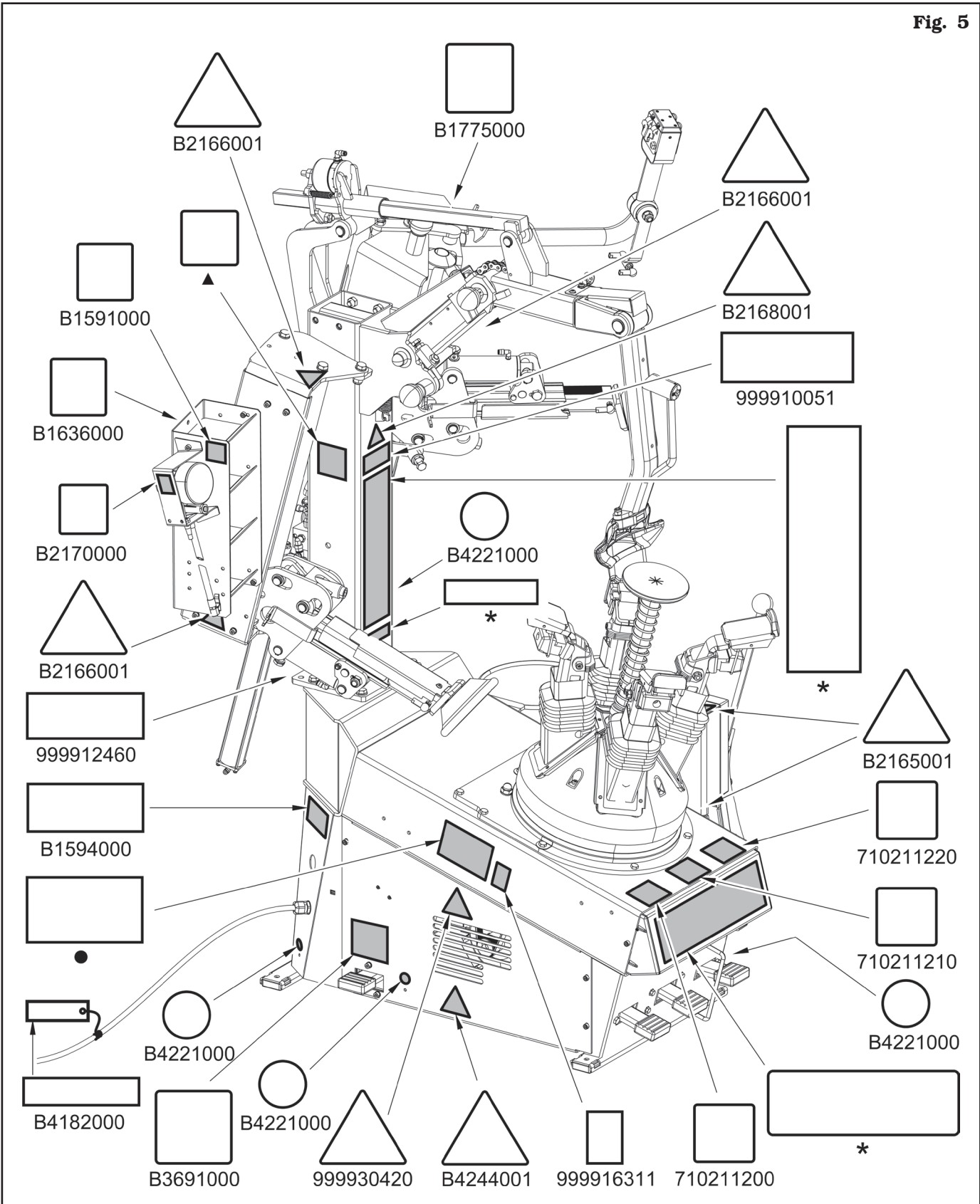

Code numbers of nameplates

B1591000	<i>Red hose indicating nameplate</i>
B1594000	<i>Date indicating nameplate</i>
B1636000	<i>Black hose indicating nameplate</i>
B1775000	<i>Oil quantity nameplate</i>
B2165001	<i>Lateral bead breaker danger nameplate</i>
B2166001	<i>Bead breaker danger nameplate</i>
B2168001	<i>Tyre burst danger indicating nameplate</i>
B2170000	<i>Max. inflation pressure rating nameplate</i>
B3691000	<i>Inflation pedal nameplate</i>
B4182000	<i>Electric motor specifications nameplate</i>
B4221000	<i>Grounding nameplate</i>
B4244001	<i>Rotating parts danger nameplate</i>
710211200	<i>Self-centring chuck opening/closing nameplate</i>
710211210	<i>Rotation direction nameplate</i>
710211220	<i>Bead breaking control nameplate</i>
999910051	<i>Protection device use nameplate</i>
999912460	<i>Supply pressure indicating nameplate</i>
999916311	<i>Rubbish skip nameplate</i>
999930420	<i>Electric shock danger nameplate</i>
▲	<i>WDK nameplate (applies to model with WDK certification)</i>
●	<i>Serial number nameplate</i>
*	<i>Manufacturer or machine name nameplate</i>



IF ONE OR MORE NAMEPLATES ARE MISSING FROM THE EQUIPMENT OR BECOMES DIFFICULT TO READ. REPLACE IT AND QUOTE ITS/THEIR PART NUMBER/S WHEN REORDERING.

PLATES LOCATION DRAWING (RAV.G1065.200792)

Fig. 6

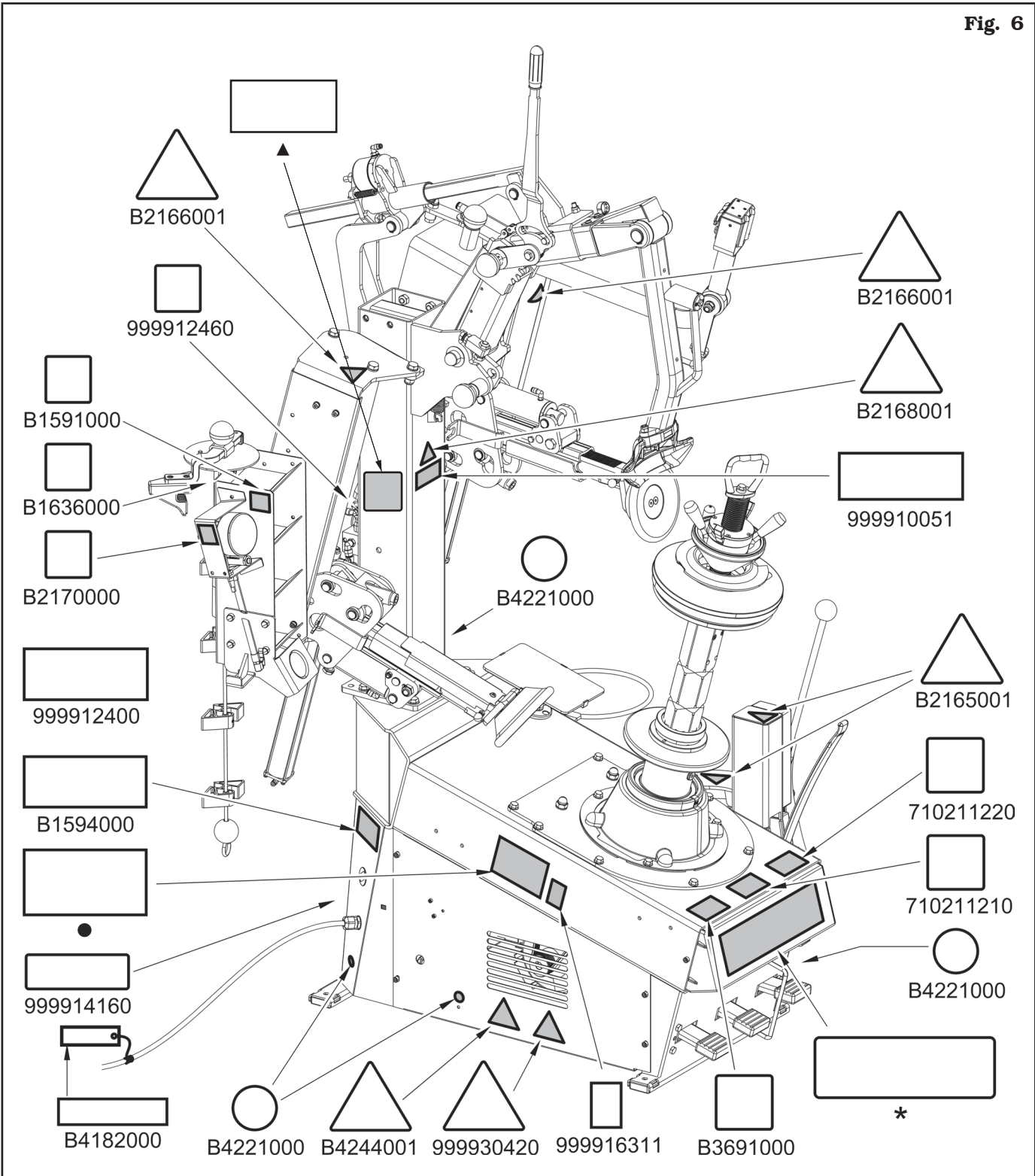

Code numbers of nameplates

B1591000	<i>Red hose indicating nameplate</i>
B1594000	<i>Date indicating nameplate</i>
B1636000	<i>Black hose indicating nameplate</i>
B2165001	<i>Lateral bead breaker danger nameplate</i>
B2166001	<i>Bead breaker danger nameplate</i>
B2168001	<i>Tyre burst danger indicating nameplate</i>
B2170000	<i>Max. inflation pressure rating nameplate</i>
B3691000	<i>Inflation pedal nameplate</i>
B4182000	<i>Electric motor specifications nameplate</i>
B4221000	<i>Grounding nameplate</i>
B4244001	<i>Rotating parts danger nameplate</i>
710211210	<i>Rotation direction nameplate</i>
710211220	<i>Bead breaking control nameplate</i>
999910051	<i>Protection device use nameplate</i>
999912460	<i>Supply pressure indicating nameplate</i>
999914160	<i>230 V - 1 Ph - 50/60 Hz voltage nameplate</i>
999916311	<i>Rubbish skip nameplate</i>
999930420	<i>Electric shock danger nameplate</i>
▲	<i>WDK nameplate (applies to model with WDK certification)</i>
●	<i>Serial number nameplate</i>
*	<i>Manufacturer or machine name nameplate</i>



IF ONE OR MORE NAMEPLATES ARE MISSING FROM THE EQUIPMENT OR BECOMES DIFFICULT TO READ. REPLACE IT AND QUOTE ITS/THEIR PART NUMBER/S WHEN REORDERING.



SOME OF THE PICTURES IN THIS MANUAL HAVE BEEN OBTAINED FROM PICTURES OF PROTOTYPES, THEREFORE THE STANDARD PRODUCTION EQUIPMENT AND ACCESSORIES CAN BE DIFFERENT THAN PICTURED.

1.0 GENERAL INTRODUCTION

This manual is an integral part of the equipment and must be retained for the whole operating life of the equipment itself.

Carefully study this manual. It contains important instructions regarding **FUNCTIONING, SAFE USE and MAINTENANCE.**



KEEP THE MANUAL IN A KNOWN EASILY ACCESSIBLE PLACE FOR ALL SERVICE TECHNICIAN TO CONSULT IT WHENEVER IN DOUBT.



THE MANUFACTURER CAN NOT BE HELD RESPONSIBLE FOR ANY DAMAGE TO THE SHOP, EQUIPMENT OR CUSTOMER WHEEL/TYRE THAT MAY OCCUR WHEN THE INSTRUCTIONS GIVEN IN THIS MANUAL ARE NOT FOLLOWED. DISREGARDING THESE INSTRUCTIONS MAY CAUSE INJURY OR DEATH.

1.1 Introduction

Thanks for purchasing this tyre changer! The tyre changer is designed and built for professional garages. The tyre changer is easy to use with safety in mind. Following the care and maintenance outlined in this tyre changer manual your tyre changer will provide years of service.

2.0 INTENDED USE

The equipment described in this manual is a tyre changer that uses two systems:

- an electric motor coupled to a reduction gearbox to handle the tyre rotation, and
- a compressed air system to manage the movement of the pneumatic cylinders with several assembly/disassembly tools.

The equipment is to be used only for the mounting, demounting, and inflation of any type of wheel with the whole rim (drop centre and with bead) with diameters and width values mentioned in "Technical specifications" chapter.



THIS EQUIPMENT MUST ONLY BE USED FOR THE PURPOSE FOR WHICH IT IS SPECIFICALLY DESIGNED. ANY OTHER USES ARE TO BE CONSIDERED IMPROPER AND THEREFORE UNACCEPTABLE.



THE MANUFACTURER CANNOT BE HELD RESPONSIBLE FOR ANY DAMAGES CAUSED BY IMPROPER, ERRONEOUS, OR UNACCEPTABLE USE.

2.1 Training of personnel

The machine may be operated only by suitably trained and authorized personnel.

Given the complexity of the operations necessary to manage the equipment and carry out the operations safely and efficiently, the personnel must be trained in such a way that they learn all the information necessary to operate the machine as intended by the manufacturer.



CAREFULLY READING THIS INSTRUCTION MANUAL AND A SHORT PERIOD OF TRAINING BY SKILLED PERSONNEL REPRESENT A SATISFACTORY FORM OF TRAINING.

3.0 SAFETY DEVICES



DAILY CHECK THE INTEGRITY AND THE FUNCTIONALITY OF THE SAFETY AND PROTECTION DEVICES ON THE EQUIPMENT.

The product is equipped with:

- **Anti-tilt protection for the arm**

This device prevents the arm from hitting the operator.

- **Upper bead breaker clamping (standard on some models)**

A device preventing the upper bead-breaker from coming out when the motor turns clockwise.

- **Fixed protections and guards**

This equipment has permanent guards installed to avoid potential risks of getting crushed, cut or squeezed.

These protections have been realized after risks evaluation and after all equipment operative situations have been considered.

All protections, specially the rubber ones, have to be periodically checked in order to evaluate their wear state.



PERIODICALLY CARRY OUT THE MAINTENANCE OF THE PROTECTIONS, SHIELDS AND SAFETY DEVICES IN GENERAL, AS INDICATED IN CHAPTER 13. ROUTINE MAINTENANCE.

- **Motor protection devices**

The motor with inverter is equipped with electronic protection devices. They stop the motor if working defected conditions appear, to avoid that the motor itself can be damaged and that the operator safety can be compromised (overvoltage, overload, over-temperature). For other details, see the chapt. 14 "Fault-Finding".

- **Maximum pressure valve.**

This prevents an excess of pneumatic supply. It adjusts the maximum air inlet to 10 bar (145 psi). This valve is calibrated by the manufacturer and cannot be re-calibrated.

- **Non-adjustable pressure limiter.**

This allows inflation of tyres in reasonable safety. In fact, this limiter does not allow inflation of tyres to over 4.2 ± 0.2 bar (60 ± 3 psi) (see **Fig. 7**).

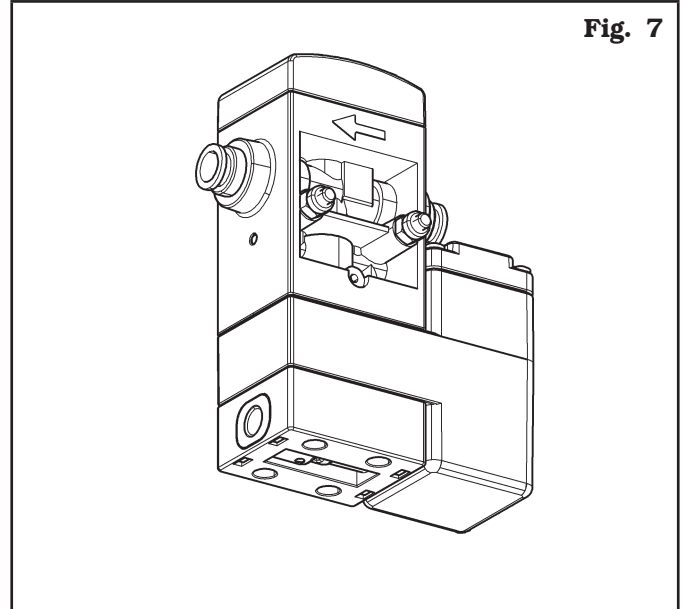

Fig. 7

3.1 Residual risks

The equipment was subjected to a complete analysis of risks according to reference standard EN ISO 12100. Risks are as reduced as possible in relation with technology and equipment functionality.

Any residual risks have been highlighted in this manual through pictograms and adhesive warning signals placed on the equipment: their location is represented in "PLATE LOCATION DRAWING" (see **Fig. 4**, **Fig. 5** and **Fig. 6**).

4.0 IMPORTANT SAFETY INSTRUCTIONS

When using your garage equipment, basic safety precautions should always be followed, including the following:

1. Read all instructions.
2. Care must be taken as burns can occur from touching hot parts.
3. Do not operate equipment with a damaged cord or if the equipment has been dropped or damaged – until it has been examined by a qualified service person.
4. Do not let a cord hang over the edge of the table, bench, or counter or come in contact with hot manifolds or moving fan blades.
5. If an extension cord is necessary, a cord with a current rating equal to or more than that of the equipment should be used. Cords rated for less current than the equipment may overheat. Care should be taken to arrange the cord so that it will not be tripped over or pulled.
6. Always unplug equipment from electrical outlet when not in use. Never use the cord to pull the plug from the outlet. Grasp plug and pull to disconnect.
7. Let equipment cool completely before putting away. Loop cord loosely around equipment when storing.
8. To reduce the risk of fire, do not operate equipment in the vicinity of open containers of flammable liquids (gasoline).
9. Adequate ventilation should be provided when working on operating internal combustion engines.
10. Keep hair, loose clothing, fingers, and all parts of body away from moving parts.
11. To reduce the risk of electric shock, do not use on wet surfaces or expose to rain.
12. Use only as described in this manual. Use only manufacturer's recommended attachments.
13. ALWAYS WEAR SAFETY GLASSES. Everyday eyeglasses only have impact resistant lenses, they are not safety glasses.

SAVE THESE INSTRUCTIONS

4.1 General safety rules



- Any tampering with or modification to the machine not previously authorized by the manufacturer exempts the latter from all responsibility for damage caused by or derived from said actions.
- Removing of or tampering with the safety devices or with the warning signals placed on the equipment leads to serious dangers and represents a transgression of European safety standards.
- The equipment may be used only in areas free from the danger of explosion or fire.
- The use of only original accessories and spare parts is advised. Our equipment is designed to function only with original accessories.
- The installation must be performed by qualified personnel in full compliance with the instructions given below.
- Ensure that there are no dangerous situations during the machine operating manoeuvres. Immediately stop the equipment if it malfunctions and contact the customer service of the authorized dealer.
- In emergency situations and before carrying out any maintenance or repairs, isolate the equipment from energy sources by disconnecting the electrical and/or pneumatic power supply using the main switch.
- Ensure that the area around the equipment is free of potentially dangerous objects and that the area is oil free since this could damage the tyre. Oil on the floor is also a slipping hazard for the operator.



THE MANUFACTURER DENIES ANY RESPONSIBILITY IN CASE OF DAMAGES CAUSED BY UNAUTHORIZED MODIFICATIONS OR BY THE USE OF NON ORIGINAL COMPONENTS OR EQUIPMENT.



OPERATORS MUST WEAR SUITABLE WORK CLOTHES, PROTECTIVE GLASSES AND GLOVES, AGAINST THE DANGER FROM THE SPRAYING OF DANGEROUS DUST, AND POSSIBLY LOWER BACK SUPPORTS FOR THE LIFTING OF HEAVY PARTS. DANGLING OBJECTS LIKE BRACELETS MUST NOT BE WORN, AND LONG HAIR MUST BE TIED UP. FOOTWEAR SHOULD BE ADEQUATE FOR THE TYPE OF OPERATIONS TO BE CARRIED OUT.



- The equipment handles and operating grips must be kept clean and free from oil.
- The workshop must be kept clean and dry and not in an out doors location. Make sure that the working premises are properly lit.
The equipment can be operated by a single operator at a time. Unauthorized personnel must remain outside the working area, as shown in **Fig. 11**. Avoid any hazardous situations. Do not use this equipment when the shop is damp or the floor slippery and do not use this equipment out doors.
- During inflation do not lean on the tyre or stand on it; when beading in the tyre, keep hands away from tyre and rim edge.
- During inflation always stay to the side of the equipment and never in front of it.
- When operating and servicing this equipment, carefully follow all in force safety and accident-prevention precautions.
The equipment must not be operated by untrained personnel.
- Never activate the inflation device (on model with tubeless inflation system) if the tyre has not been correctly locked.



ALWAYS KEEP THE CONTROLS IN THE NEUTRAL POSITION.

5.0 PACKING AND MOBILIZATION FOR TRANSPORT



HAVE THE EQUIPMENT HANDLED BY SKILLED PERSONNEL ONLY.



THE LIFTING EQUIPMENT MUST WITHSTAND A MINIMUM RATED LOAD EQUAL TO THE WEIGHT OF THE PACKED EQUIPMENT (see paragraph "TECHNICAL SPECIFICATIONS").

The equipment is packed partially assembled. Handling must be by pallet-lift or fork-lift trolley. The fork lifting points are indicated on the packing, **Fig. 8**.

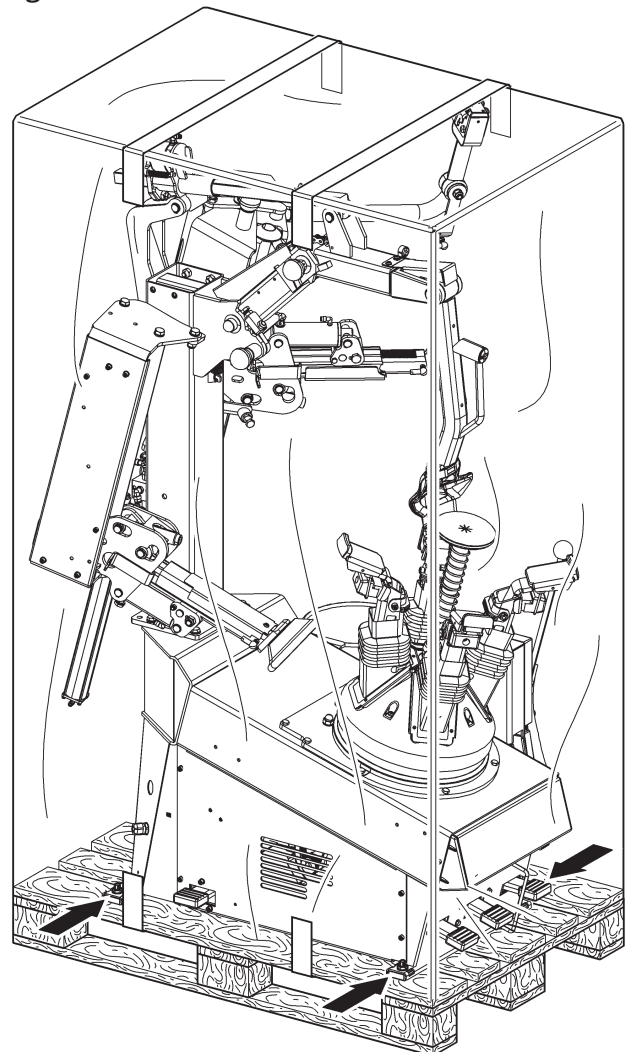
Fig. 8



6.0 UNPACKING

DURING UNPACKING, ALWAYS WEAR GLOVES TO PREVENT ANY INJURY CAUSED BY CONTACT WITH PACKAGING MATERIAL (NAILS, ETC.).

The cardboard box is supported with plastic strapping. Cut the strapping with suitable scissors. Use a small knife to cut along the lateral axis of the box and open it like a fan.

It is also possible to unnailed the cardboard box from the pallet it is fixed to. After removing the packing, and in the case of the equipment packed fully assembled, check that the machine is complete and that there is no visible damage.

If in doubt **do not use the equipment** and refer to professionally qualified personnel (to the seller).

The packing (plastic bags, expanded polystyrene, nails, bolts, timber, etc.) should not be left within reach of children since it is potentially dangerous. These materials should be deposited in the relevant collection points if they are pollutants or non biodegradable.



THE BOX CONTAINING THE ACCESSORIES IS CONTAINED IN THE WRAPPING. DO NOT THROW IT AWAY WITH THE PACKING.

7.0 MOBILIZATION



THE LIFTING EQUIPMENT MUST WITHSTAND A MINIMUM RATED LOAD EQUAL TO THE WEIGHT OF THE EQUIPMENT (SEE PARAGRAPH TECHNICAL SPECIFICATIONS). NON FAR ALLOW THE LIFTED EQUIPMENT TO SWING.

During the equipment handling from the unpacking position to the installation one, follow the instructions listed below.

- Protect the exposed corners with suitable material (bubble wrap/cardboard).
- Do not use metallic cables for lifting.
- Make sure that the equipment power supply is not connected.
- Lift and transport with suitable device with adequate dimensions.
- Block, through knob A, the free movement of the bead breaker (applies to models with upper bead breaker clamping control) (**Fig. 10 ref. A**).
- Sling with a 100 cm (39.37") long belt, with a capacity load greater than 1000 kg (2205 lbs) as shown in **Fig. 9 and Fig. 10**.

**Applies to ROT.CLASS.201713,
 ROT.CLASS.200440 and RAV.G1001.200815
 models**

Fig. 9

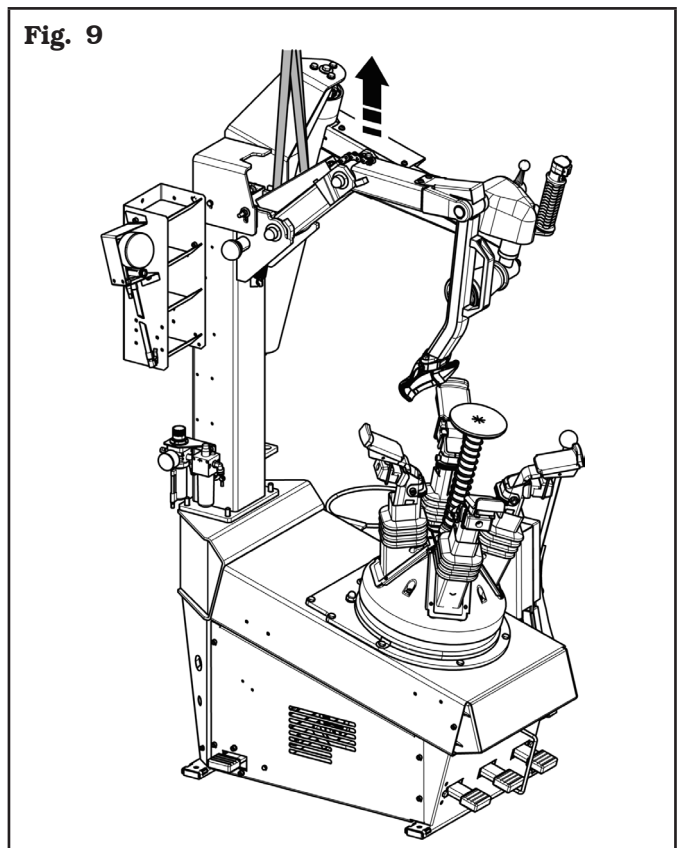

Applies to ROT.COMBI.201706,
ROT.COMBI.200525 and RAV.G1065.200792
models

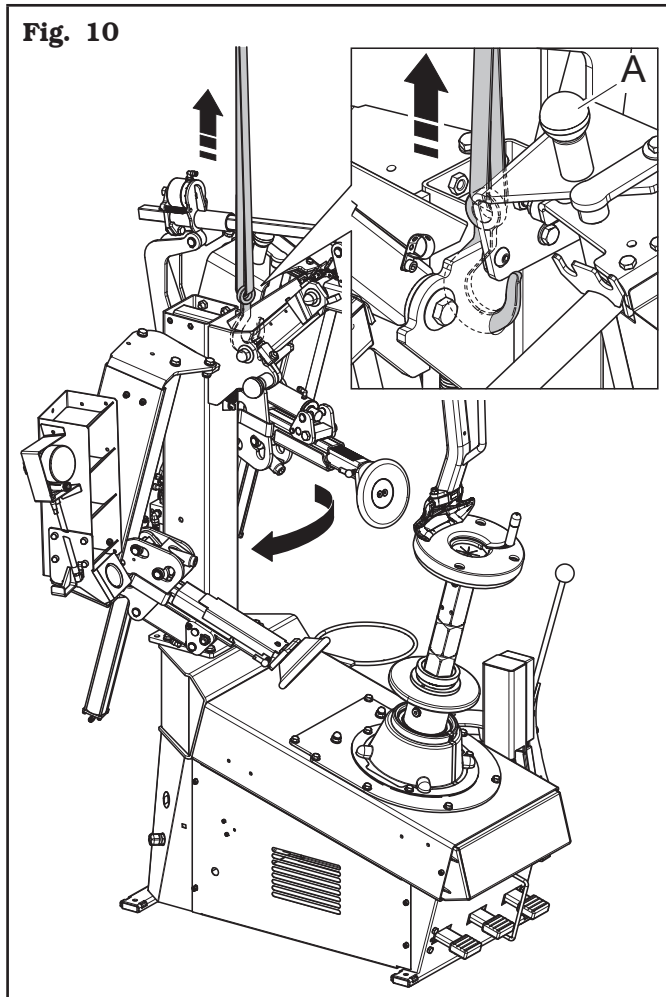

8.0 WORKING ENVIRONMENT CONDITIONS

The equipment must be operated under proper conditions as follows:

- temperature: +5 °C - +40 °C (+41 °F - +104 °F)
- relative humidity: 30 - 95% (dew-free)
- atmospheric pressure: 860 - 1060 hPa (mbar) (12.5 - 15.4 psi).

The use of the equipment in ambient conditions other than those specified above is only allowed after prior agreement with and approval of the manufacturer.

8.1 Work position

In **Fig. 11** it is possible to identify work positions **A** and **B**.

Position **A** is the main position for wheel fitting and removal with the chuck, while position **B** is ideal to follow wheel bead breaking operations.

Working in these positions allows better precision and speed during operating phases as well as greater safety for the operator.

8.2 Working area

Fig. 11

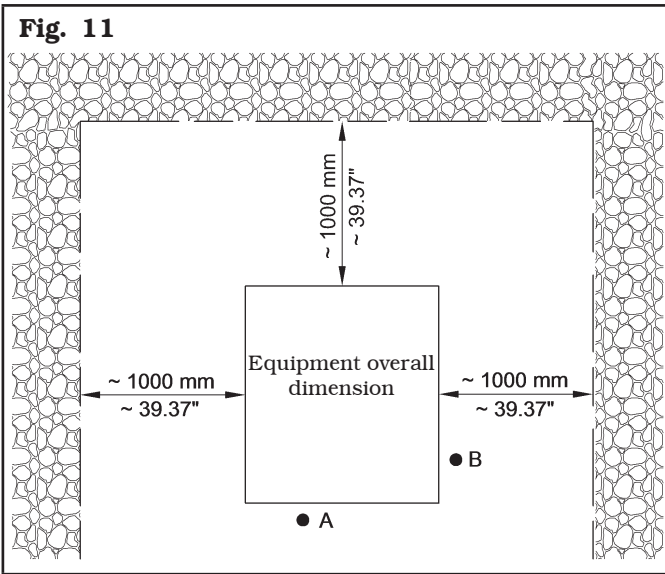

USE THE EQUIPMENT IN A DRY AND SUFFICIENTLY ILLUMINATED PLACE, CLOSED, PROTECTED FROM ALL WEATHER CONDITIONS AND COMPLYING WITH THE REGULATIONS IN FORCE REGARDING WORK SAFETY.

The location of the equipment requires a usable space as indicated in **Fig. 11**. The positioning of the equipment must be executed according to the distances shown. From the control position the operator is able to observe all the equipment and surrounding area. Operator must prevent unauthorized personnel or objects that could be dangerous from entering the area. The equipment must be secured to a flat floor surface, preferably of cement or tiled. Avoid yielding or irregular surfaces.

The equipment base floor must be able to support the loads transmitted during operation. This surface must have a capacity load of at least 500 kg/m² (100 lb/ft²). The depth of the solid floor must guarantee the tightness of the anchor plugs.

8.3 Lighting

The equipment must be placed in a sufficiently lit environment in compliance with current regulations.

9.0 ASSEMBLY AND PREPARATION FOR USE

ALL EQUIPMENT ASSEMBLY OR ADJUSTMENTS MUST BE CARRIED OUT BY PROFESSIONALLY QUALIFIED STAFF.

After removing the various components from the packing, check that they are complete, and that there are no missing or damaged parts, then use the following instructions for the assembly of the components making use of the following series of illustrations.

9.1 Anchoring system

The packed equipment is secured to the support pallet through the holes on the frame and indicated in the figure below. These holes can be used to secure the equipment to the floor, using suitable concrete anchors (not included). Before concrete anchoring to floor, check that all the anchor points are flat, or level in contact with the floor. If not, shim between the equipment and the floor, as indicated in **Fig. 12**.

Fig. 12

	ROT.CLASS.201713 ROT.CLASS.200440 RAV.G1001.200815	ROT.COMBI.201706 ROT.COMBI.200525 RAV.G1065.200792
a	603 mm / 23.74"	714 mm / 28.11"
b	420 mm / 16.54"	

- To secure the equipment to the floor, use anchoring bolts/studs (**Fig. 12 ref. 1**) with a threaded shank M8 (UNC 5/16) suitable for the floor on which the tyre changer will be secured and in a number equal to the number of mounting holes on the bottom frame;
- drill holes in the floor, suitable for inserting the chosen anchors, in correspondence with the holes on the bottom frame;
- insert the anchors into the holes drilled in the floor through the holes on the bottom frame and tighten the anchors;
- tighten the anchors on the base frame and torque as indicated by the manufacturer of the anchors.

9.2 Assembly procedures

Remove the packaging and free the equipment from the wrapping. The tyre-changer is usually made up of the following main assemblies (see **Fig. 13**):

ref. 1 tool box (standard on some models);

ref. 2 bead press device (standard on some models).

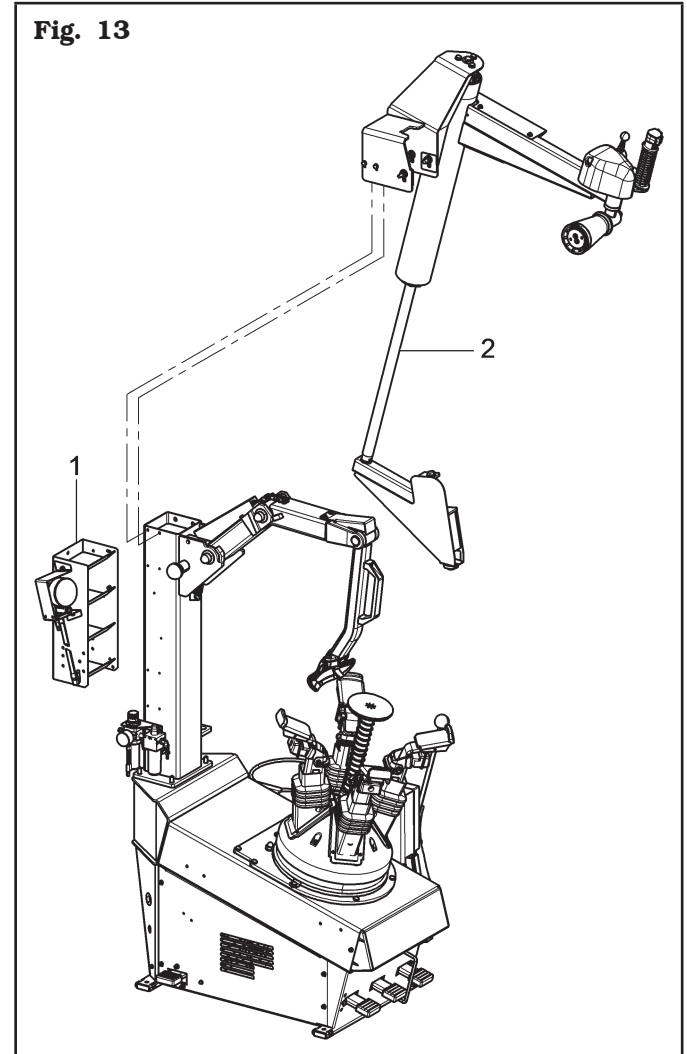

Proceed with the assembly of the equipment by following the steps described below.

On models with Bead press device

1. Position the bead press device near the equipment (**Fig. 14 ref. 1**);
2. secure the upper support (**Fig. 14 ref. 2**) to the column (**Fig. 14 ref. 3**) with the bolts (**Fig. 14 ref. 4**), the washers (**Fig. 14 ref. 5**) and the nuts (**Fig. 14 ref. 6**) supplied;
3. fit the lower support (**Fig. 14 ref. 7**) to the side bead breaker (**Fig. 14 ref. 8**), using bolt (**Fig. 14 ref. 9**), washers (**Fig. 14 ref. 10**) and nut (**Fig. 14 ref. 11**) supplied;

Fig. 14

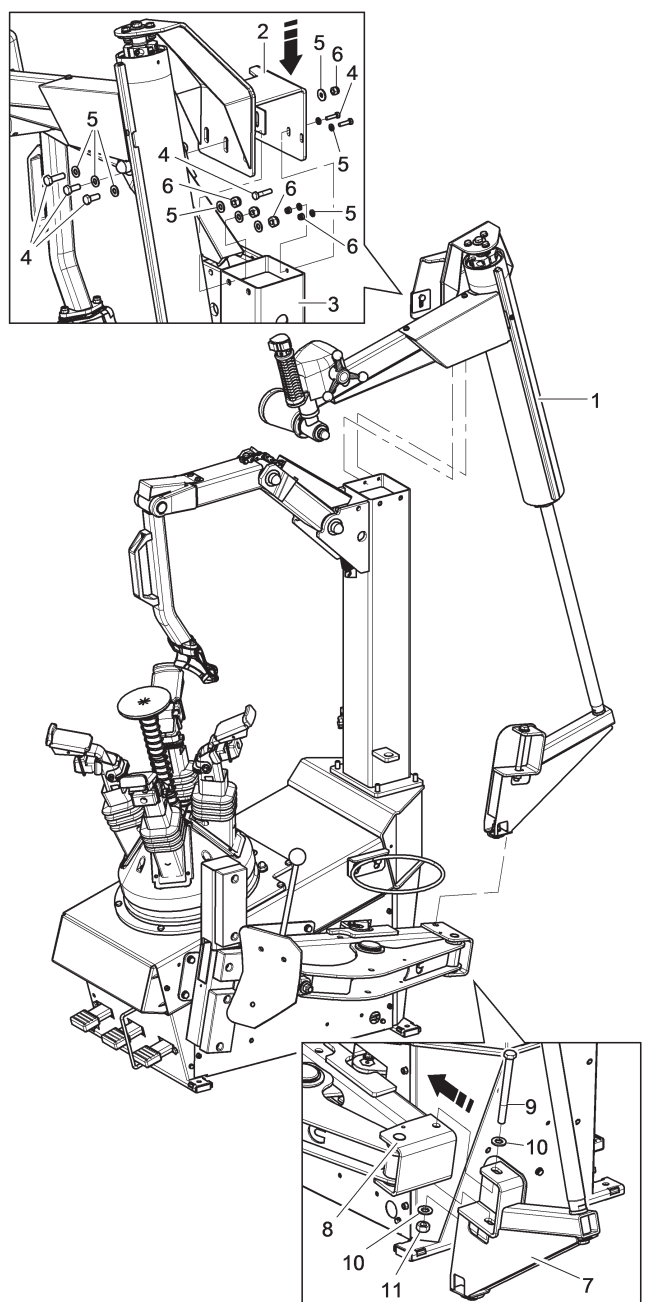

On models with Tool box

4. remove the packing from the tool box (**Fig. 15 ref. 1**) complete with pressure gauge and take the piece off the wrapping;

On models with Bead press device

5. fit the tool box (**Fig. 15 ref. 1**) using a bolt (**Fig. 15 ref. 2**) and a washer (**Fig. 15 ref. 3**) of the upper support of the bead press device (**Fig. 15 ref. 4**), a bolt (**Fig. 15 ref. 5**) and insert the spacer (**Fig. 15 ref. 6**) supplied;

Fig. 15

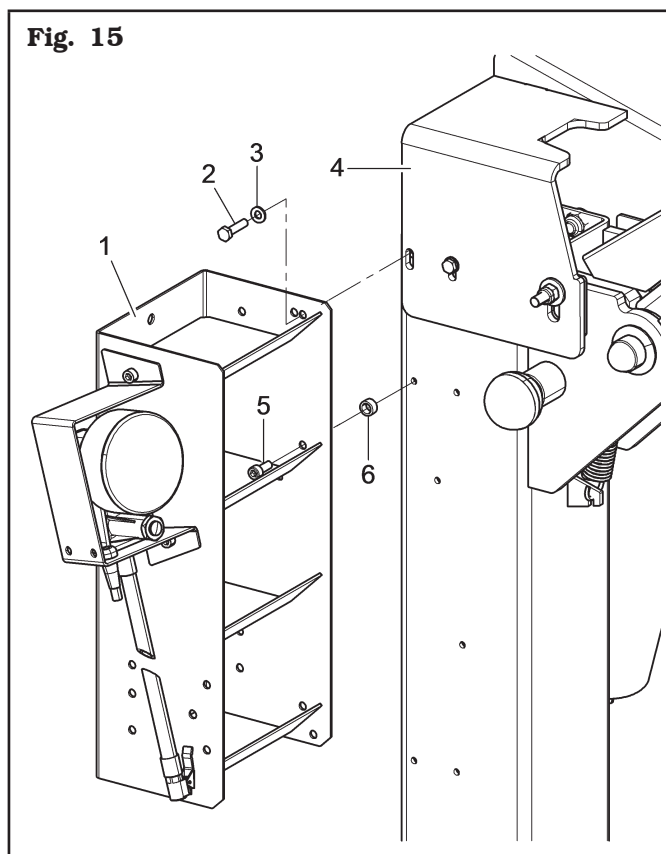

On models with upper and lower bead breaker

- fit the tool box (**Fig. 16 ref. 1**) to the lower bead breaker (**Fig. 16 ref. 2**), using the bolts (**Fig. 16 ref. 3**), and the nuts (**Fig. 16 ref. 4**) supplied.

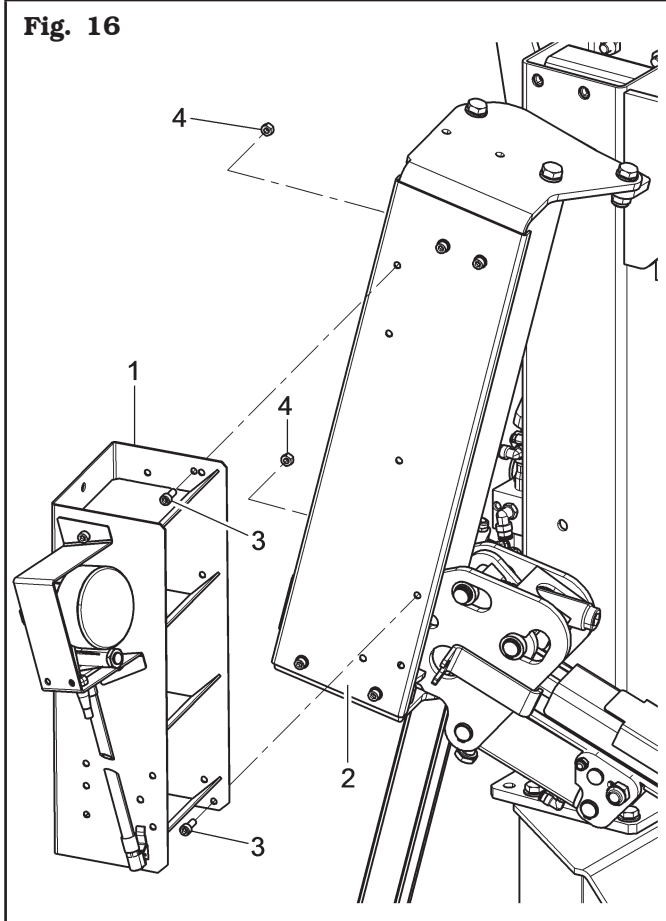

On models with Inflation gun

- screw the hook (**Fig. 17 ref. 1**) to the column (**Fig. 17 ref. 2**) with the nut (**Fig. 17 ref. 3**) supplied.

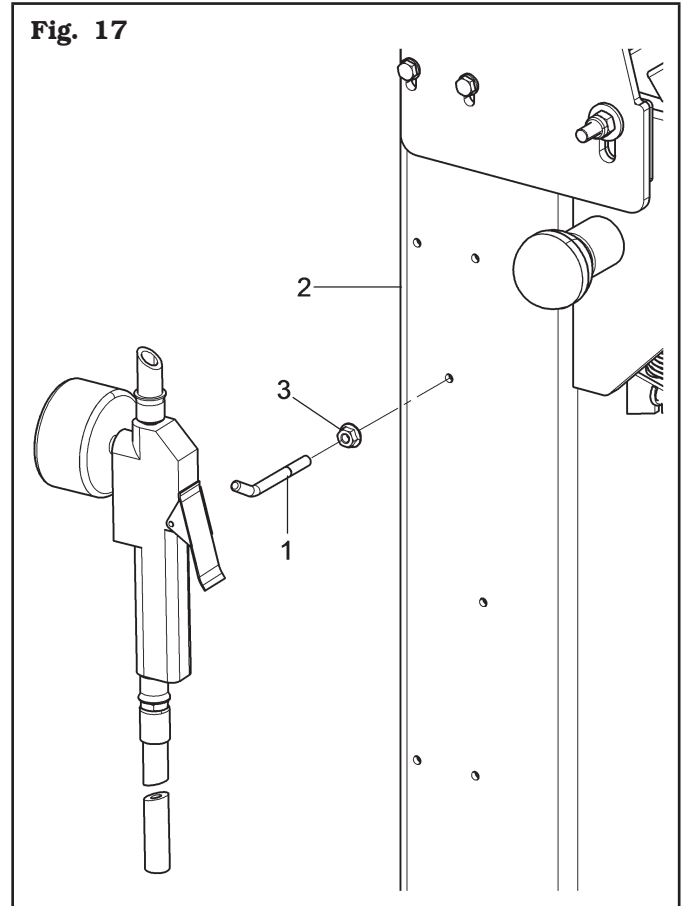



9.3 Connection to the compressed air supply

 ANY PNEUMATIC ATTACHMENTS MUST BE CARRIED OUT BY QUALIFIED STAFF.

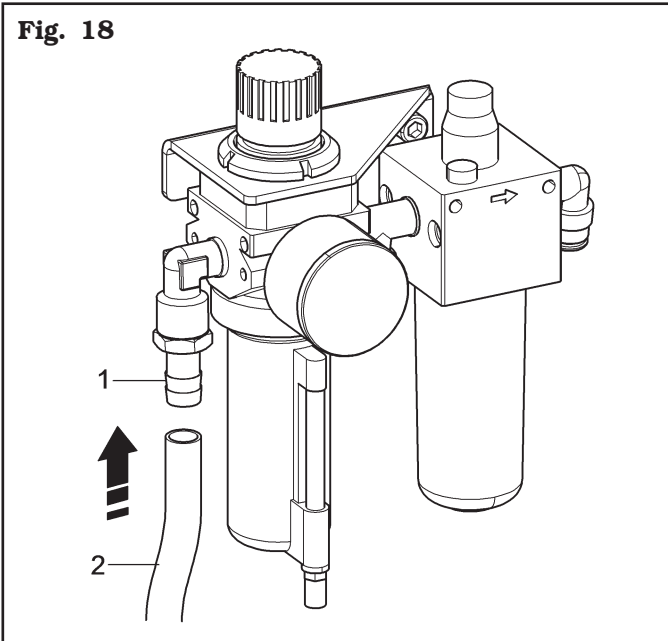
Connect the mains pneumatic supply through the fitting (**Fig. 18 ref. 1**) placed on equipment filter assembly. The pressurized hose (**Fig. 18 ref. 2**) coming from the mains must have a minimum inner diameter of 10 mm (3/8") and a minimum outer diameter of 19 mm (3/4") (see **Fig. 18**) to have sufficient flow (see **Fig. 18**).



 THE MINIMUM OPERATING PRESSURE OF THE SUPPLY HOSE AND INSTALLED FITTINGS MUST BE AT LEAST 300 psi. THE MAXIMUM BURST PRESSURE OF THE SAME MUST BE AT LEAST 900 psi.

 USE A SUITABLE PNEUMATIC THREADED CONNECTION SEALING TAPE FOR ALL PNEUMATIC CONNECTIONS.

 IF OTHER PNEUMATIC CONNECTIONS SHOULD BE EXECUTED, REFER TO THE PNEUMATIC DIAGRAMS ILLUSTRATED IN CHAPTER 19.

 IN CASE OF A CHANCE SUPPLY FAILURE, AND/OR BEFORE ANY PNEUMATIC CONNECTIONS, MOVE THE CONTROLS TO THE NEUTRAL POSITION.

10.0 ELECTRICAL CONNECTIONS



ALL ELECTRICAL CONNECTIONS ARE TO BE DONE BY QUALIFIED PERSONNEL ONLY.



BEFORE CONNECTING THE EQUIPMENT MAKE SURE THAT:

- **POWER LINE SPECIFICATIONS CORRESPOND TO EQUIPMENT REQUIREMENTS AS SHOWN ON THE MACHINE NAMEPLATE;**
- **ALL MAIN POWER COMPONENTS ARE IN GOOD CONDITION;**
- **THE ELECTRICAL SYSTEM IS PROPERLY GROUNDED (GROUND WIRE MUST BE THE SAME CROSS-SECTION AREA AS THE LARGEST POWER SUPPLY CABLES OR GREATER);**
- **MAKE SURE THAT THE ELECTRICAL SYSTEM FEATURES A PADLOCKABLE MAIN SWITCH AND A CUTOUT WITH DIFFERENTIAL PROTECTION SET AT 30 mA.**

The equipment is supplied with a cable. A plug corresponding to the following requirements must be connected to the cable:



FIT A TYPE-APPROVED (AS REPORTED BEFORE) PLUG TO THE EQUIPMENT CABLE (THE GROUND WIRE IS YELLOW/GREEN AND MUST NEVER BE CONNECTED TO ONE OF THE PHASE LEADS OR TO THE NEUTRAL).



MAKE SURE THAT THE ELECTRICAL SYSTEM IS COMPATIBLE WITH THE RATED POWER REQUIREMENTS SPECIFIED IN THIS MANUAL AND APT TO ENSURE THAT VOLTAGE DROP UNDER FULL LOAD WILL NOT EXCEED 4% OF RATED VOLTAGE (10% UPON START-UP).



FAILURE TO OBSERVE THE ABOVE INSTRUCTIONS WILL IMMEDIATELY INVALIDATE THE WARRANTY AND MAY DAMAGE THE EQUIPMENT.

As envisaged by the regulations in force, the product is not equipped with a master circuit breaker, but simply has a plug-socket connection to the electrical mains.

Motor power supply	Conformity standard	Voltage	Amperage	Poles	Minimum IP rating
Power supply 1 Ph, inverter motor	IEC 309	200/240V	16A	2 Poles + Ground	IP 44

11.0 CONTROLS

11.1 Bead press device control unit (stand- ard on some models)

It is made up of a push-button panel (**Fig. 19 ref. 1**), positioned next to the same device. This push-button panel allows to operate the vertical movement of the bead press roller (**Fig. 19 ref. 2**). By pressing button (**Fig. 19 ref. B**) downwards movement is operated, while by pressing button (**Fig. 19 ref. A**), upwards movement is operated. The device positioning next to the tyre is a completely hand-operated action. When handwheel (**Fig. 19 ref. C**) is rotated, roller (**Fig. 19 ref. 2**) is directed radially as compared to the rim.

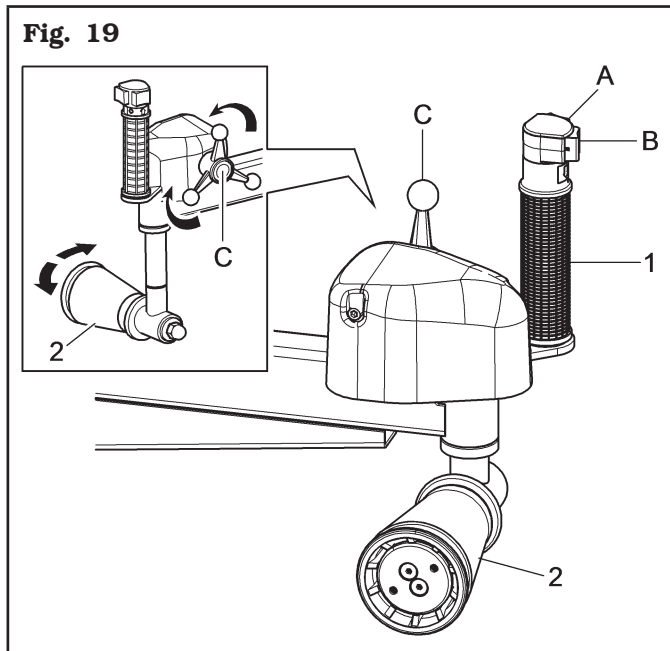

11.2 Pedalboard (applies to models with self-centring chuck)

“**Pedal 1**” has two hold-to-run control operative positions. Pressed down, it produces the self-centring chuck arm opening movement; the pedal lifting produces the self-centring chuck arms closing.

“**Pedal 2**” has two hold-to-run control operative positions. Pressed down, it controls the self-centring chuck motor clockwise rotary movement. When the pedal is lifted upwards it operates the opposite movement.

“**Pedal 3**” has one hold-to-run control operative position. When pressed down, it operates the bead breaker arm closing. Releasing the pedal, the arm returns to rest position.

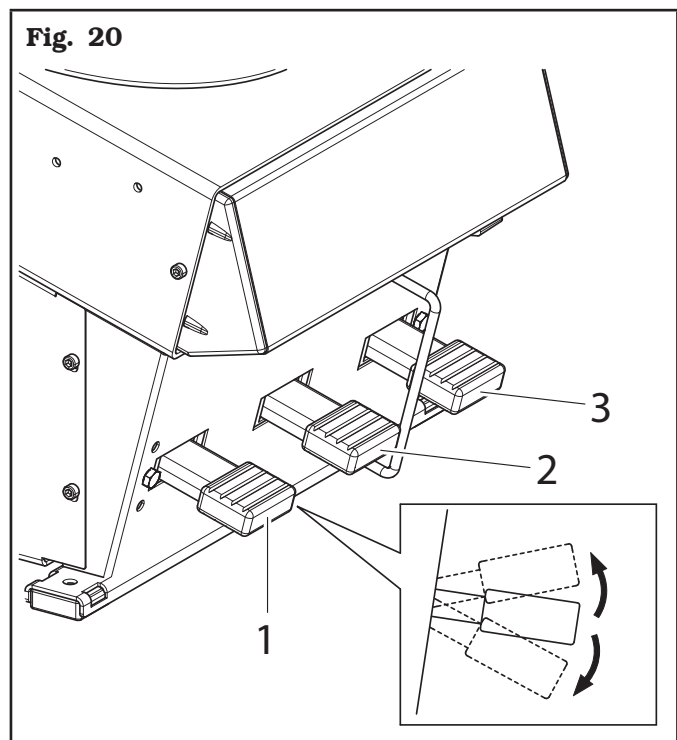

11.3 Inflation pedal (standard on some models)

The **inflation pedal** (Fig. 19 ref. 1) has only one function: with a hold-to-run control, it supplies air at a controlled pressure (max 4.2 ± 0.2 bar / 60 ± 3 psi).

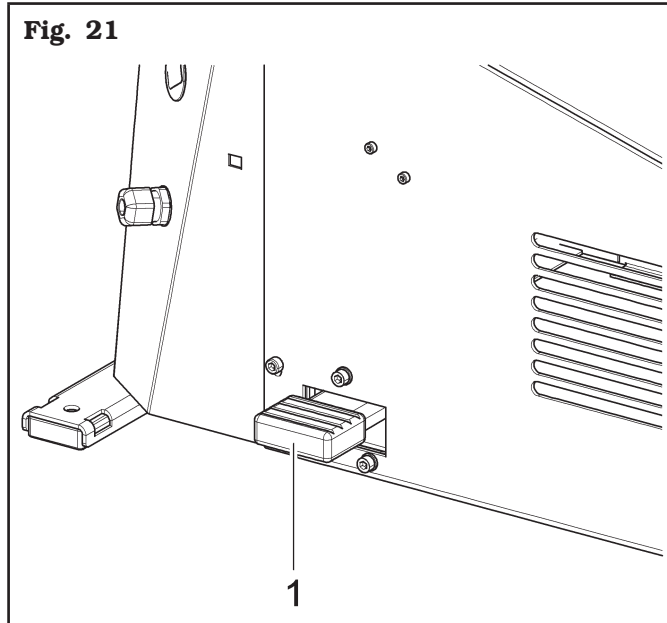



DO NOT CHANGE THE SET OPERATING PRESSURE VALUE BY MEANS OF THE MAXIMUM PRESSURE VALVES. THE MANUFACTURER SHALL NOT BE RESPONSIBLE FOR INJURY OR DAMAGE ARISING FROM UNAUTHORISED CHANGES.

11.4 Tool arm control (standard on some models)

This is done completely manually. The toolhead is positioned for work.

In order to manually adjust the tool arm, it's necessary to keep the unlocking push button (Fig. 22 ref. 1) on the handle pressed.

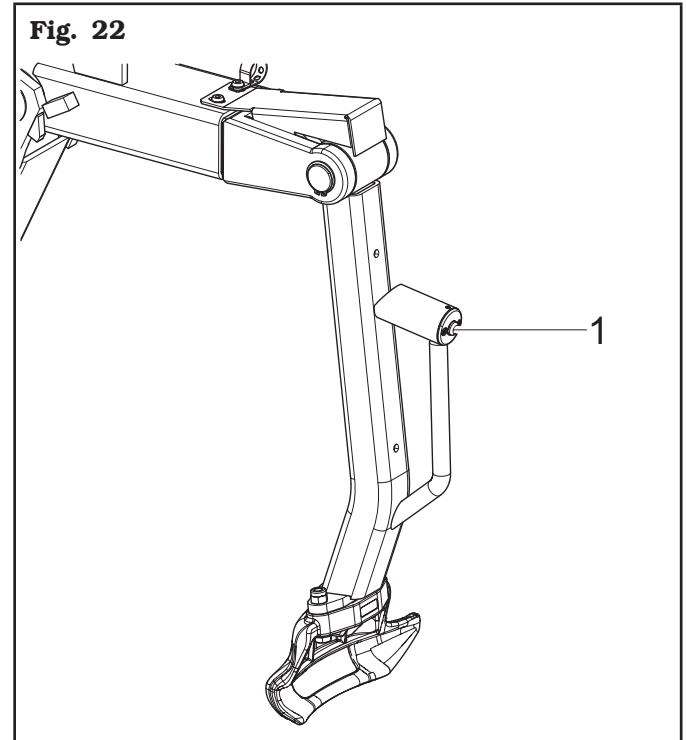

11.5 Bead breaker control unit (applies to models with upper and lower bead breaker)

It consists of two push buttons with a different function, inserted on a single control block.

The unit can be gripped for moving the bead-breakers and positioning them for operation.

The bead-breaker control unit therefore governs all the movements necessary for a complete bead-breaking operation:

- manual shift movement of the bead breakers;
- push and pull movement of the command assembly for the manual setting of the wheel diameter. The diameter indication is shown on the scale provided on the handle support.

The two pneumatic buttons on the unit control the upper and lower bead breaker arms.

Each button has three positions:

1. the **first one is rest position** (the bead breaker arms are open);
2. the **second position** of each button, of a stable operating type, generates a movement in the bead breaker arm. The right button moves the upper arm downwards. The left button moves the lower arm upwards;
3. the **third position** is a hold-to-run control type one. This means that when the right button is pressed again, it activates a hydraulic pump, which moves the upper bead-breaker roller. Vice versa, pressing the left button again starts the hydraulic movement of the lower roller. Releasing the pressure on the buttons stops the movement, the arms remain in the position reached (see **Fig. 23**).

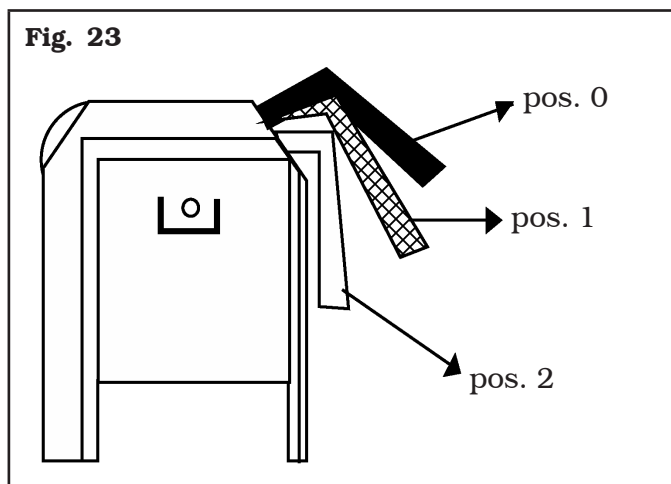

11.6 3-pedal pedalboard (applies to model with flat chuck)

The inflation “**pedal 1**” has only one function. A continuous pressure supplies air at a controlled pressure (max 4.2 ± 0.2 bar / 60 ± 3 psi).

“**Pedal 2**” has two hold-to-run control operative positions. When it is pushed downwards it controls chuck motor clockwise rotary movement. When the pedal is lifted upwards it operates the opposite movement.

“**Pedal 3**” has one hold-to-run control operative position. When pressed down, it operates the bead breaker arm closing. Releasing the pedal, the arm returns to rest position.

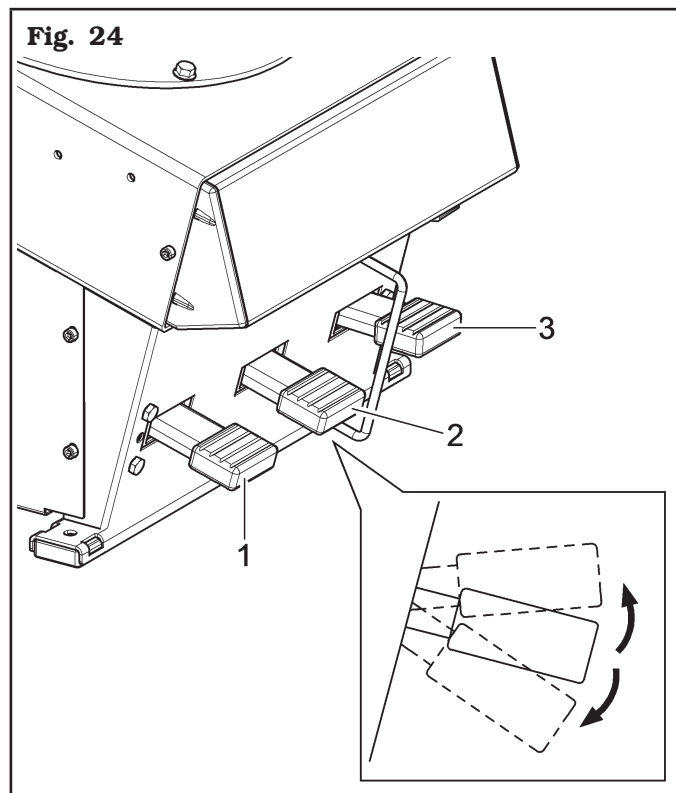

12.0 USE OF THE EQUIPMENT

12.1 Precaution measures during tyre removal and fitting



Before fitting a tyre, observe the following safety rules:

- rim and tyre must always be clean, dry and in good condition; if necessary, clean the rims and check that:
 - neither the beads, the sidewalls nor the tread of the tyre are damaged;
 - the rim does not have any dents and/or deformations (especially for alloy rims, dents can cause internal micro-fractures, that pass unobserved at visual inspection, and can compromise the solidity of the rim and constitute danger even during inflation);
- adequately lubricate the contact surface of rim and the tyre beads, using specific tyre lubricants only;
- replace the rim valve with a new valve. if the tyre pipe has a metal valve, replace the grommet.
- always make sure that tyre and rim sizes are correct for their coupling; never fit a tyre unless you are sure it is of the right size (the rated size of rim and tyre is usually printed directly on them);
- do not use compressed air or water jets to clean the wheels on the equipment.



FITTING A TYRE WITH A DAMAGED BEAD, TREAD AND/OR SIDEWALL ON A WHEEL RIM REDUCES THE SAFETY OF A VEHICLE AND CAN LEAD TO TRAFFIC ACCIDENTS, SERIOUS INJURY OR EVEN DEATH.

IF A TYRE BEAD, TREAD OR SIDEWALL IS DAMAGED DURING REMOVAL, NEVER REFIT THE TYRE ONTO A WHEEL.

IF YOU SUSPECT THAT A BEAD, TREAD OR SIDEWALL OF A TYRE MAY HAVE BEEN DAMAGED DURING FITTING, REMOVE THE TYRE AND INSPECT IT CAREFULLY. NEVER REFIT IT TO A WHEEL IF A BEAD, TREAD OR SIDEWALL IS DAMAGED.



INADEQUATE LUBRICATION OF THE TYRE, THE RIM, THE TOOL-HEAD AND/OR THE LEVER CAN CAUSE AN ABNORMAL FRICTION BETWEEN THE TYRE AND THESE ELEMENTS DURING THE DISASSEMBLY AND/OR ASSEMBLY OF THE TYRE AND CAUSE DAMAGE TO THE TYRE ITSELF, REDUCING THE SAFETY OF A VEHICLE EQUIPPED WITH THE TYRE. ALWAYS LUBRICATE THESE ELEMENTS THOROUGHLY USING A SPECIFIC LUBRICANT FOR TYRES, FOLLOWING THE INDICATIONS CONTAINED IN THIS MANUAL.



THE USE OF AN INADEQUATE, WORN OR OTHERWISE DAMAGED LEVER TO REMOVE TYRE BEADS MAY LEAD TO DAMAGE TO A BEAD AND/OR A TYRE SIDEWALL, REDUCING THE SAFETY OF A VEHICLE EQUIPPED WITH THE TYRE ITSELF.

ONLY USE THE LEVER SUPPLIED WITH THE EQUIPMENT AND CHECK ITS CONDITION BEFORE EACH DISASSEMBLY.

IF IT IS WORN OR OTHERWISE DAMAGED, DO NOT USE IT TO REMOVE THE TYRE, BUT REPLACE IT WITH A LEVER SUPPLIED BY THE EQUIPMENT MANUFACTURER OR ONE OF ITS AUTHORIZED DISTRIBUTORS.



AN INCORRECT POSITIONING OF THE VALVE AT THE BEGINNING OF THE DISASSEMBLY AND/OR ASSEMBLY OPERATIONS OF EACH TYRE BEAD CAN CAUSE THE VALVE TO BE, DURING THESE OPERATIONS, IN OR NEAR AN AREA WHERE THE BEAD HAS FITTED INTO THE RIM DROP CENTRE.

THE BEAD COULD PRESS ON THE PRESSURE SENSOR, LOCATED UNDER THE VALVE INSIDE THE DROP CENTRE, CAUSING IT TO BREAK.

ALWAYS RESPECT THE POSITIONING OF THE VALVE AT THE BEGINNING OF EACH BEAD DISASSEMBLY AND/OR ASSEMBLY OPERATION INDICATED IN THIS MANUAL.



FAILURE TO INSERT A SUITABLE SECTION OF A BEAD INSIDE THE RIM DROP CENTRE, AS INDICATED IN THIS MANUAL DURING THE FITTING OR REMOVAL OF THE BEAD, RESULTS IN AN ABNORMAL TENSION ON THE BEAD.

THIS CAN CAUSE DAMAGE TO THE BEAD AND/OR THE SIDEWALL OF THE TYRE TO WHICH THE BEAD IS CONNECTED, REDUCING THE SAFETY OF A VEHICLE EQUIPPED WITH THE TYRE.

ALWAYS FOLLOW THE DIRECTIONS IN THE MANUAL REGARDING ALIGNMENT OF A SECTION OF A BEAD TO THE RIM DROP CENTRE.

DO NOT PROCEED WITH THE REMOVAL OR INSTALLATION OF A BEAD IF YOU ARE NOT ABLE TO ALIGN A SECTION OF A BEAD WITH THE RIM DROP CENTRE AS INDICATED IN THIS MANUAL.

12.2 Preliminary operations - Preparing the wheel

- Remove the wheel balancing weights from both sides of the wheel.



REMOVE THE VALVE STEM AND ALLOW THE TYRE TO COMPLETELY DEFLATE.

- Establish from which side the tyre should be de-mounted, checking the position of the drop centre.
- Find the rim locking type.
- Try to establish the special types of wheels, such as "TD" and "AH", in order to improve locking, bead breaking, assembly and disassembly performances.



WHEN HANDLING WHEELS WEIGHING MORE THAN 10 kg (22 lbs) AND/OR WITH A FREQUENCY OF MORE THAN 20/30 WHEELS PER HOUR, THE LIFTING DEVICE SHOULD BE USED.

12.3 Use of mounting strap with stopper (applies to models with belt kit assembly)

The use of the strap during assembly operations facilitates the insertion of the tyre bead into the drop centre.

1. During assembly, extend the strap around the perimeter of the tyre until it reaches approximately "11 o'clock" position;
2. lock it in position by pulling it slightly;



PLACE THE STRAP ON THE TYRE TREAD NEAR THE UPPER SIDE-WALL (SEE FIG. 25).

3. keep the strap tensioned on the tyre gradually and progressively, avoiding sudden blows;
4. as soon as the resistance of the bead during assembly has been overcome, immediately release the strap in order to avoid unnecessary stress on the winder;
5. when mounting avoid completely unrolling the strap (up to stroke limit).



ANY DAMAGE RESULTING FROM FAILURE TO FOLLOW THE INSTRUCTIONS MENTIONED ABOVE WILL RELEASE THE MANUFACTURER FROM ANY LIABILITY AND MIGHT CAUSE THE LOSS OF THE WARRANTY CONDITIONS!

Fig. 25

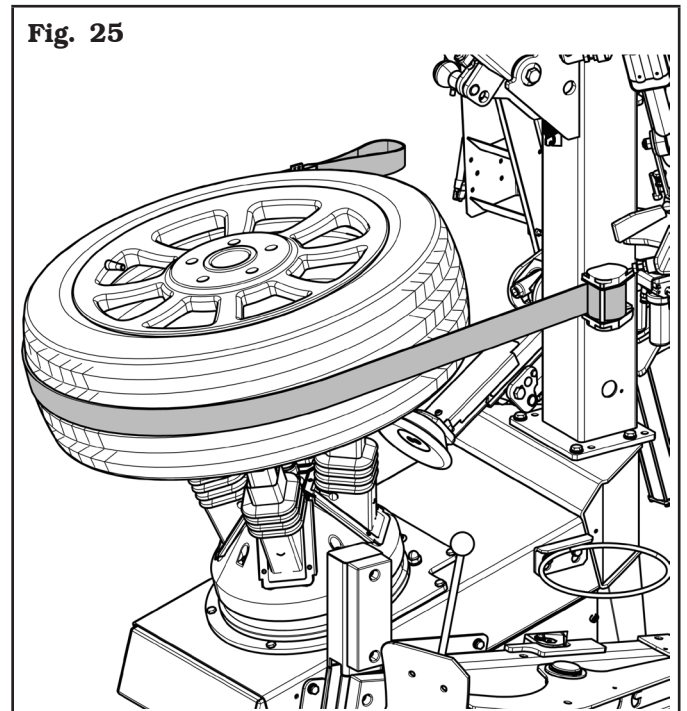

12.4 Bead breaking with side shovel



TYRE BEADING MUST BE CARRIED OUT AFTER THE TYRE HAS BEEN COMPLETELY DEFLATED AND OBSERVING ALL SAFETY RULES: BEADING PEDAL START-UP CAUSE SUDDEN, STRONG ARM CLAMPING, THUS REPRESENTING POTENTIAL CRUSHING DANGER FOR ANYTHING WITHIN THE OPERATING AREA. DO NOT KEEP YOUR HANDS ON TYRE SIDES DURING BEAD BREAKING. DURING TYRE BEADING SUDDEN NOISE LEVEL PEAKS CAN OCCUR: THEREFORE THE USE OF SAFETY EARPLUGS IS RECOMMENDED.

After preparing the wheel as described in the previous point, follow the instructions given below to carry out the bead breaking procedure:

1. position the wheel as indicated in **Fig. 26** and move the bead breaker shovel toward the edge of the rim;



PLACE THE SHOVEL CORRECTLY, SO THAT IT CAN OPERATE ON TYRE SIDE AND NOT ON THE RIM.

Fig. 26

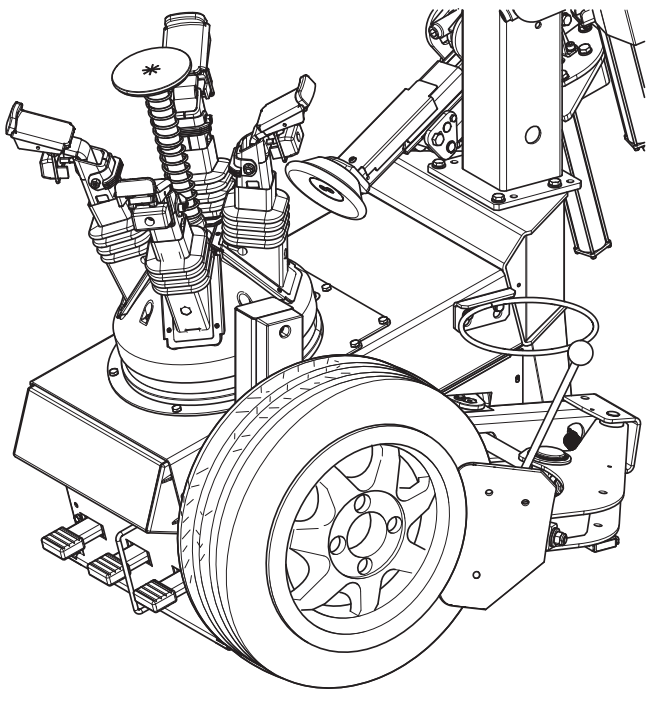

On models with Stroke limiter

2. adjust the travel of the bead breaker stroke limiter by acting on its adjustment ring nut (**Fig. 27 ref. 1**), so that the shovel can penetrate beyond the edge of the rim for a height equal to the height of a wedge of the bead press extension;

Fig. 27

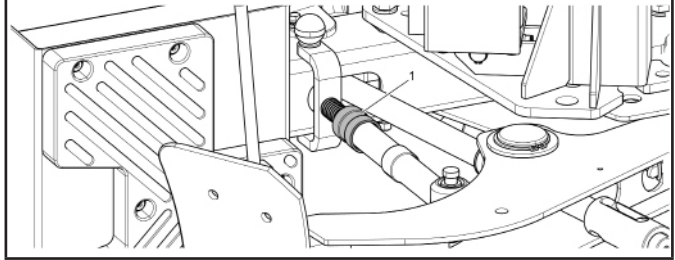

For all models

3. operate the bead breaker shovel by pressing the proper pedal until the bead has detached. If the bead does not detach the first time, repeat the operation, on different points of the wheel, until it has come away completely;
4. reverse the position of the wheel and repeat the operation on the other side;
5. lubricate the tyre carefully along the entire circumference of the bead on both sides. Failure to lubricate might cause friction between the shovel and the tyre, and would cause damage to the tyre and/or the bead.



NEVER INSERT ANY PART OF YOUR BODY BETWEEN THE BEAD BREAKER SHOVEL AND THE TYRE, OR BETWEEN THE TYRE AND THE WHEEL SUPPORT.

12.5 Wheel clamping (applies to models with self-centring chuck)

All wheels must be locked from the inside, using rubber protectors. These rubber protectors must be positioned on a smooth part of the rim.



THE RUBBER COVERED JAWS WITH HOOK HAVE ALWAYS TO BE REMOVED BEFORE CLAMPING THE RIM FROM THE INSIDE.

It is advisable to lock the rim as high as possible. To lock the wheel proceed as follows:

- close the self-centring arms by moving the proper pedal upwards;
- put the wheel on the spring centring device and press until the rubber protectors are at the point on the rim that is to be locked;
- then, push down on the pedal until the wheel is completely locked;
- check that the rim is clamped and centred correctly to ensure that the rim will not slip during the operations which follow.



THE WHEEL MUST ALWAYS BE FIXED WITH THE SAFETY DEVICE AND RELEASED FROM THE DEVICE ONLY AFTER THE COMPLETION OF ALL THE OPERATIONS.

It might be necessary to work on a wheel with reversed drop centre, which creates the problem of how to lock this wheel from the outside.

In such cases proceed as follows:

- lock the wheel from the inside as previously shown;
- carry out bead-breaking;
- unlock the wheel and turn it;
- open the self-centring arms by pushing the proper pedal until there is enough space to insert the wheel;
- insert the four rubber covered jaws with hook;
- position the wheel and close the self-centring arms by lifting the pedal until the wheel is locked.

12.6 Wheel clamping (applies to model with flat chuck)

All wheels must be locked on the rubber plate (**Fig. 21 ref. 6**) through the central hole using the proper locking device (**Fig. 28 ref. 2**).

Fig. 28

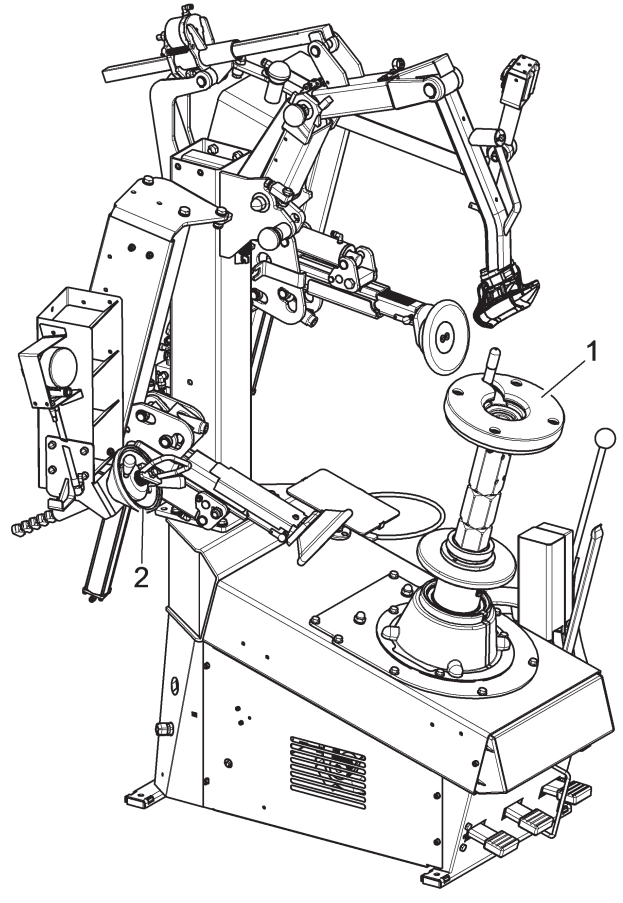

IN CASE OF USE OF RIMS WITHOUT CENTRAL HOLE, IT'S NECESSARY TO USE THE PROPER ACCESSORY (AVAILABLE ON DEMAND).

To lock a rim proceed as follows:

1. dowel the wheel (**Fig. 29 ref. 1**) on the locking platform and check that the puller pin (**Fig. 29 ref. 2**) enters a hole on the rim hub;

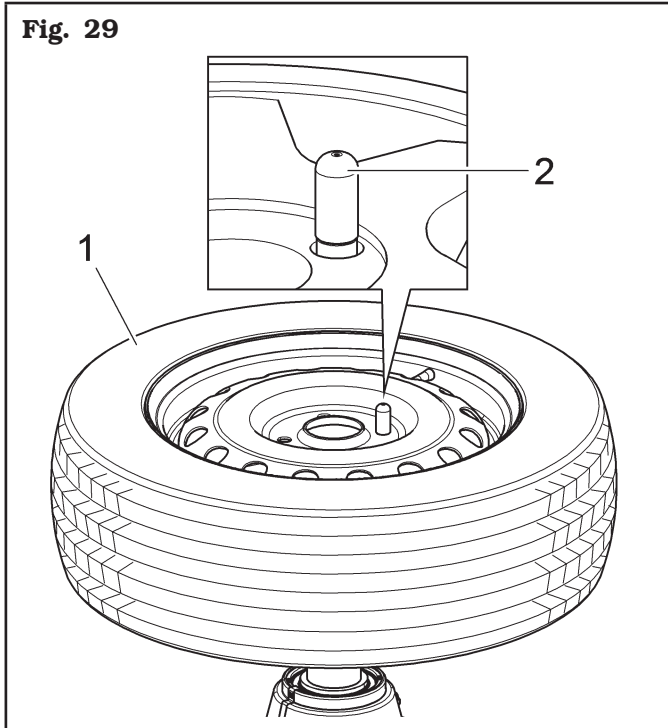

2. if the wheel hub is higher than the puller (**Fig. 30 ref. 2**), use the extension (**Fig. 30 ref. 1**) supplied;

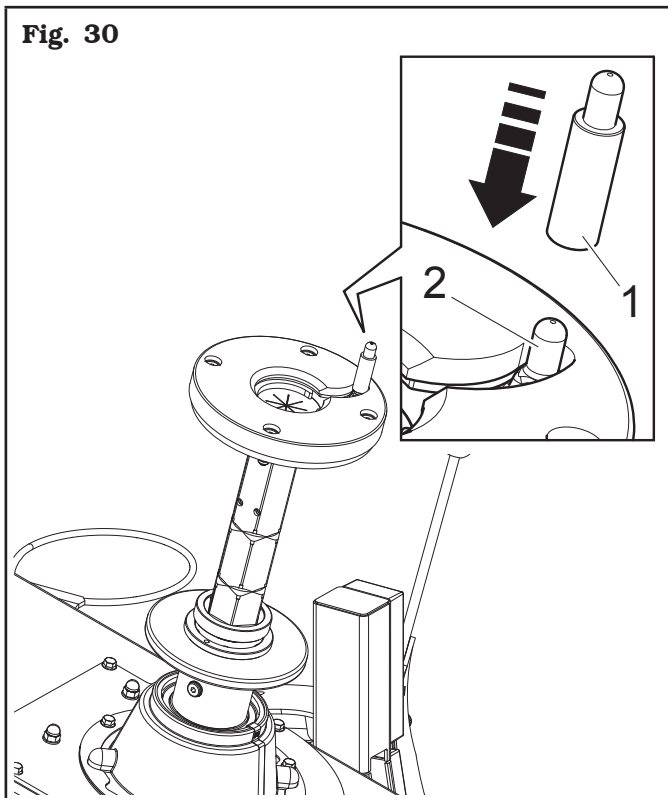

3. insert the locking shaft (**Fig. 31 ref. 1**) on the rim (**Fig. 31 ref. 2**);

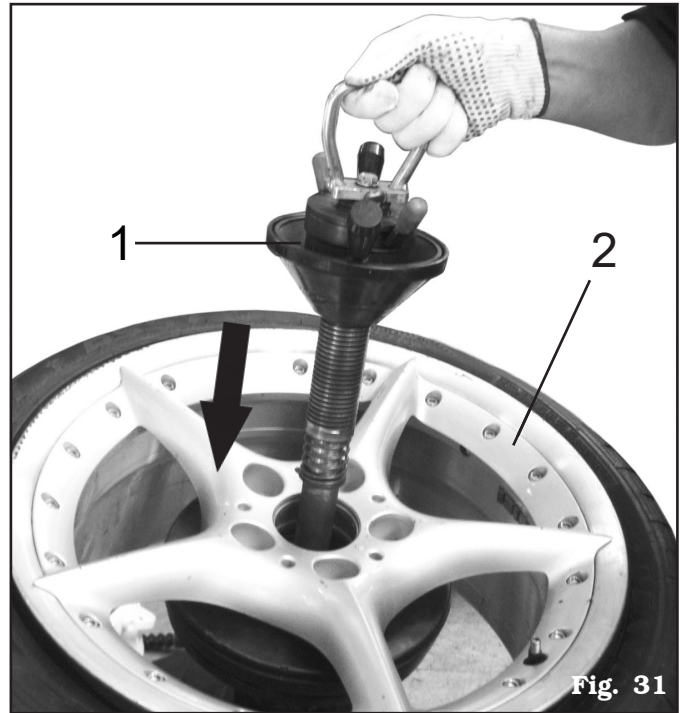

2. using the handle shown (**Fig. 32 ref. 1**), push downwards (**Fig. 32 ref. 2**), turn it through 90° (**Fig. 32 ref. 3**);

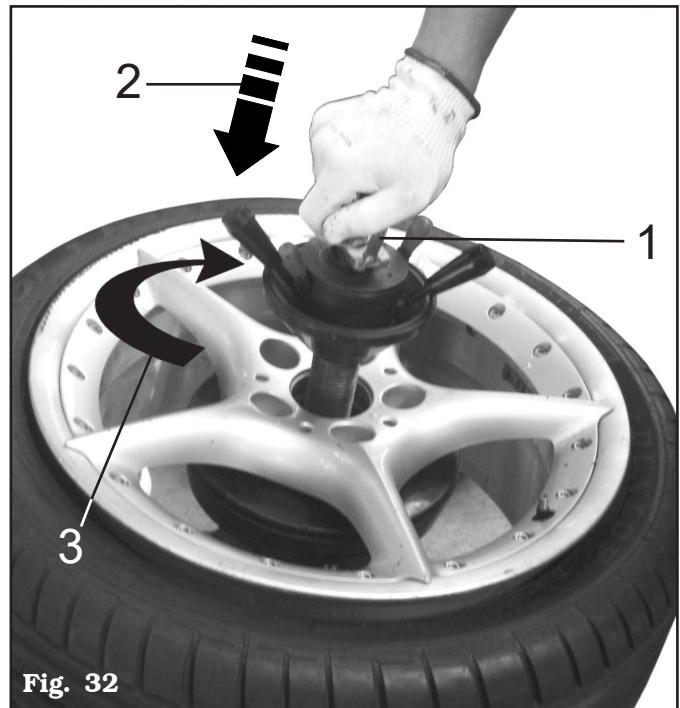

5. using the small inside levers (**Fig. 33 ref. 1**), loose the ring nut and push ring nut (**Fig. 33 ref. 3**) and cone (**Fig. 33 ref. 4**) to the rim (**Fig. 33 ref. 2**);

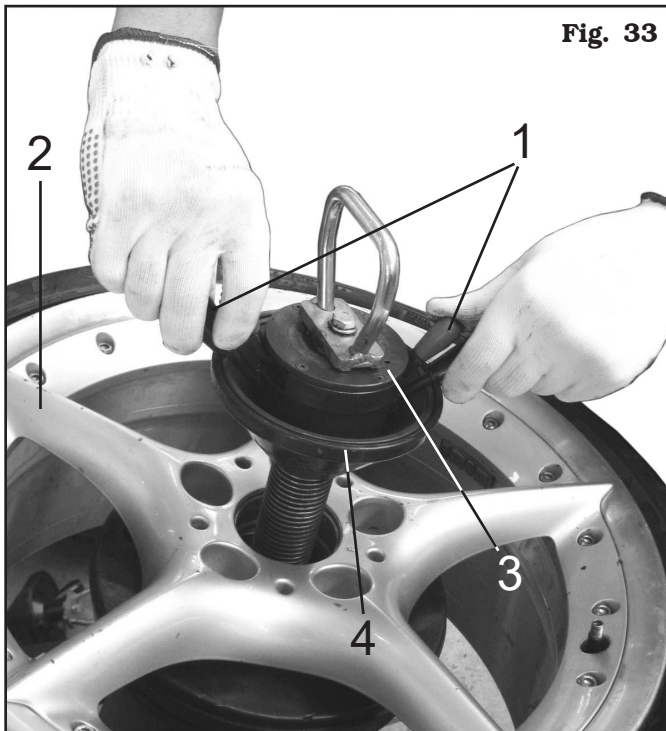

Fig. 33

6. then, turn the ring nut (**Fig. 34 ref. 1**) using the outside levers (**Fig. 34 ref. 2**) until the cone completely clamps (**Fig. 34 ref. 3**) the wheel (**Fig. 34 ref. 4**);

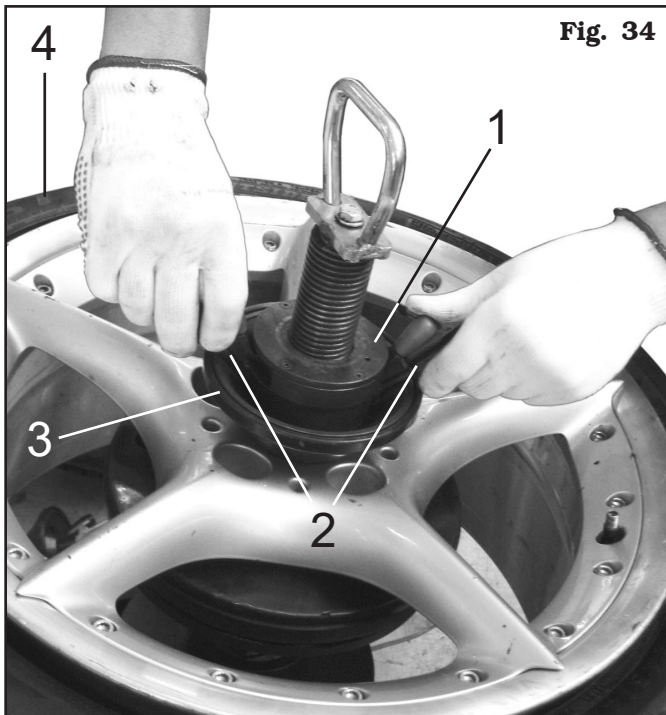

Fig. 34

7. for wheels with alloy rims, use the proper plastic guard (**Fig. 35 ref. 1**);

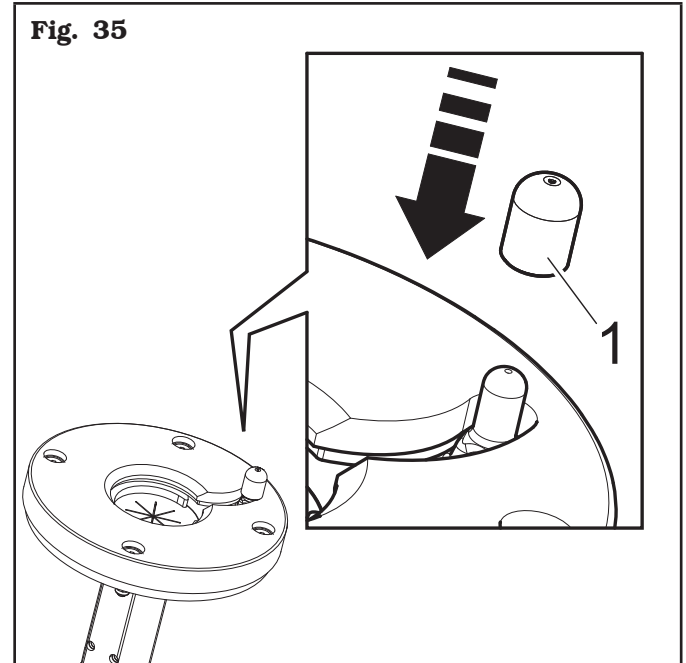

Fig. 35

8. at the end of the operations, loosen the locking shaft releasing first the cone using the outside levers and then moving the ring nut and the cone away from the rim with the small levers;
9. lower the locking shaft to release it from its seat, turn it 90° counter-clockwise and extract it from the hole using the handle.



NEVER LEAVE THE WHEEL FITTED ON THE EQUIPMENT FOR A PERIOD LONGER THAN NECESSARY FOR DOING THE WORK AND NEVER LEAVE IT UNATTENDED.

12.6.1 Chuck height adjustment (applies to model with flat chuck)

The chuck with central locking has 3 different height mode. A “quick release” system allows to remove the chuck mobile part and to dowel the support plate at the desired height.

The adjustment through the sliding shaft is possible following three phases as indicated on the enclosed photo.



TO CARRY OUT THE OPERATIONS LISTED BELOW, NO WHEEL MUST BE POSITIONED AND SECURED ON THE CHUCK.

1. lift the flange to release the wheel support as indicated by the arrows (**Fig. 36 ref. 1**);
2. at the same time lift the wheel support as indicated by the arrows (**Fig. 36 ref. 2**);
3. check that the flange returns to its position.

Now it's possible to place the tyre in the right way with the working tools.

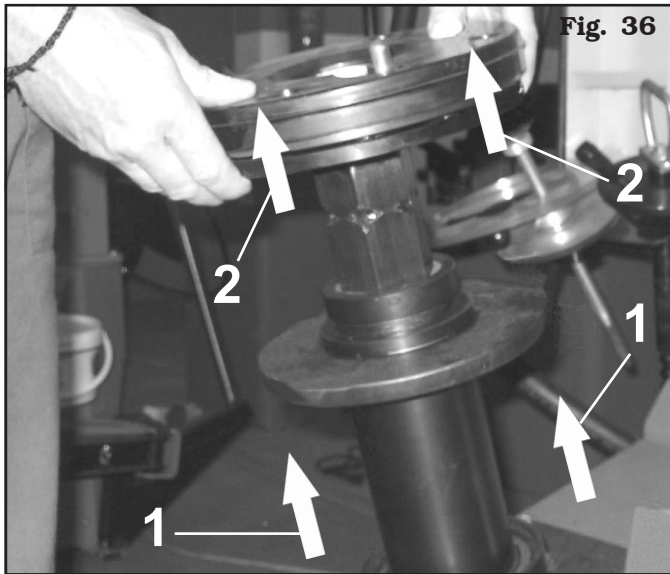

12.6.2 Reverse wheel pan protection (applies to model with flat chuck)

In case reversed wheels are used, in order to protect the rim, apply on the rubber platform a protection (**Fig. 37 ref. 1**), supplied. We suggest replacing it if there are visible damages (see **Fig. 37**).

Fig. 37

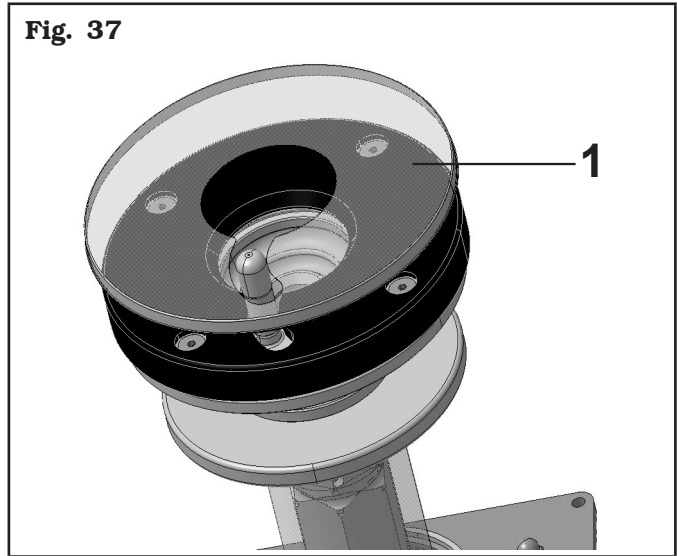

12.7 Bead breaking by means of vertical rollers (applies to models with upper and lower bead breaker)

To proceed with bead breaking operations using vertical rollers, follow the instructions below:

1. after having locked the wheel, move the upper bead-breaker to its work position;
2. set the wheel diameter by moving the control backwards or forwards referring to the diameter scale on the control unit. This scale is purely **indicative** since rims of equal diameter are not all the same;
3. move the upper bead breaker roller down until it touches the tyre using the button on the right side of the control unit and leave it in this position against the side of the rim (see **Fig. 38**);

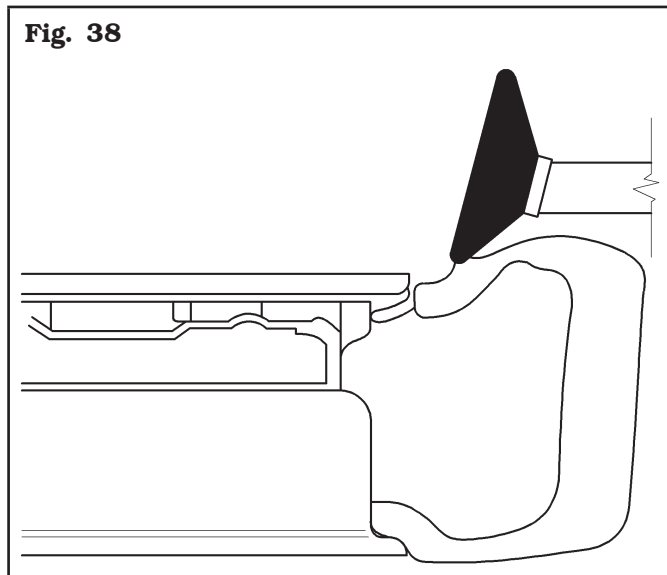

4. start the hydraulic pump, again with the right button, until the roller locks onto the tyre (locking is complete when the roller moves forward);
5. move the lower bead breaker roller up by pressing the left button until it touches the tyre;
6. start the hydraulic pump, again with the left button, until the roller locks onto the tyre;
7. rotate the wheel anti-clockwise pushing the proper pedal upwards and simultaneously pressing the left button to bead-break the bottom (it is possible to follow the operation using the magnetic mirror mounted on the lower bead breaker);
8. once the bead breaking of the lower part has been completed, the lower bead breaker roller is moved back to the rest position by pressing the left button to position 0;
9. proceed to bead-break the upper edge in the same way, but using the right control unit button.

Instructions for bead-breaking “TD” and “AH” tyres and rims

Tyres and rims type “TD”

1. Bead-break one bead at a time starting with the upper bead;
2. position the roller 1cm from the edge of the rim;
3. rotate the wheel anti-clockwise and simultaneously press the right button of the upper bead breaker to activate the hydraulic pump;
4. keep the hydraulic pump in operation until there is space enough between tyre and rim to lubricate the bead;
5. continue with the pump until the bead is completely broken;
6. rotate the wheel to bead it from the lower side. The bead may reverse. In this case, remove the roller and start again re-positioning the roller against the edge of the rim and use the full power of the equipment until the bead is broken.

Tyres and rims type “AH”

After having locked the rim proceed as follows:

1. lubricate the edge of the tyre;
2. place the rollers as usual;
3. bead break one bead at a time starting from the lower bead.



FOR “TD” AND “AH” WHEELS IT IS ADVISABLE THAT THE AIR SUPPLY PRESSURE NEVER FALLS BELOW 8 bar (116 psi).

12.8 Tyre disassembly (applies to models with bead press device)

When both beads are broken, the tyre can be demounted:

1. press the pedal to rotate the wheel clockwise until the valve stem reaches "1 o'clock" position;
2. position the mounting/demounting arm on the rim outer edge.

It is important to position the mounting arm correctly (there are 4 possible positions). The four positions are set using the knob on the post and manually moving the arms until they are locked in the desired position. The correct position is achieved when the angle between the tool holder arm and the rim plate is 90° (see **Fig. 39**).

This position is important because:

- it reduces the tension during mounting/demounting;
- it spreads the force applied to the toolhead over the largest area possible;
- it significantly reduces the wear of the toolhead.

Fig. 39

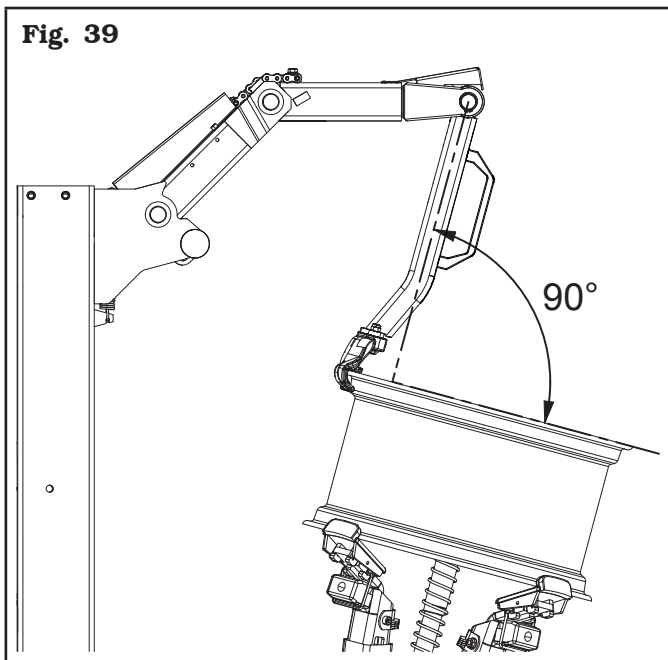

3. Place the bead press roller (**Fig. 40 ref. 1**), as shown in figure (not far from the toolhead (**Fig. 40 ref. 2**)). Lower the tyre using the bead press roller (**Fig. 40 ref. 1**) (by pressing the relevant button (**Fig. 40 ref. B**) on the control unit), until allowing an easy toolhead positioning (**Fig. 40 ref. 2**);

Fig. 40

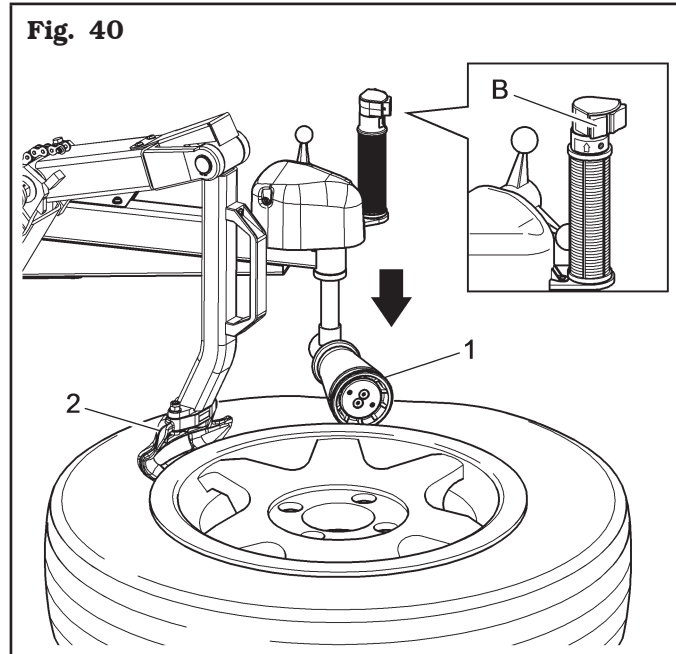

4. move the lever protector to the pointed end of the bead lifting lever. Insert the bead lifting lever (**Fig. 41 ref. 3**) between the tyre (**Fig. 41 ref. 4**) and the toolhead (**Fig. 41 ref. 2**). Use the same lever (**Fig. 41 ref. 5**), to lift the bead onto the right end of the toolhead (**Fig. 41 ref. 2**) and position it parallel with the rim plate, at the same time press on the side of the tyre at "6 o'clock" position;
5. lift bead press roller (**Fig. 41 ref. 1**) of the bead press device, by operating the relevant button (**Fig. 41 ref. A**) on the control unit;
6. press the pedal to turn the wheel clockwise (**Fig. 41 ref. 6**) until the whole bead has been lifted from the rim. During the rotation of the wheel, the bead lifting tool slides away from the toolhead moving onto the rim edge. The plastic protector prevents the lever from scratching the rim;



WITH ROUNDED OR FLAT EDGE RIMS, THE ARM SHOULD HAVE AN ANGLE OF 100°/110°.

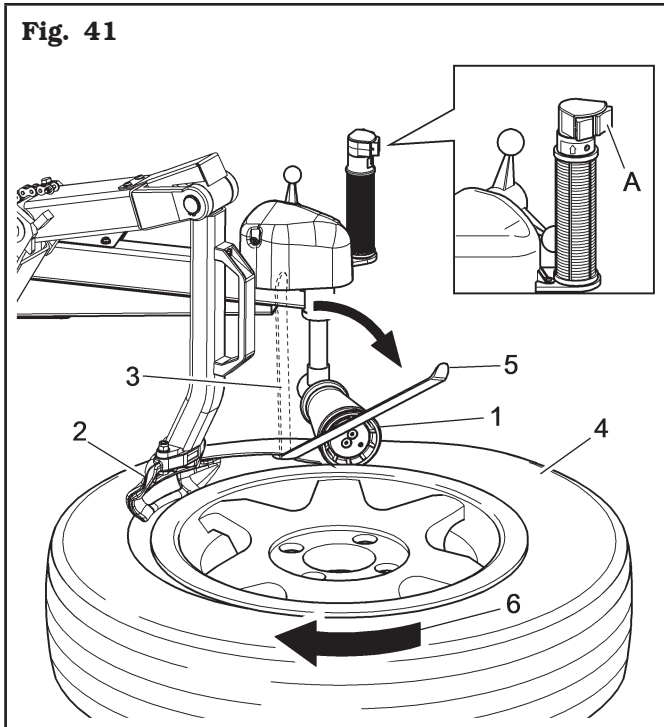

7. lift the tyre and repeat the operation on the other bead;
8. when demounting hard tyres, the bead may come onto the toolhead with the lip turned. This causes the bead to slide from the lever, when clockwise rotation begins. To avoid this problem rotate the wheel slightly anti-clockwise until the bead flattens. Now the clockwise demounting cycle can begin (see **Fig. 42**);

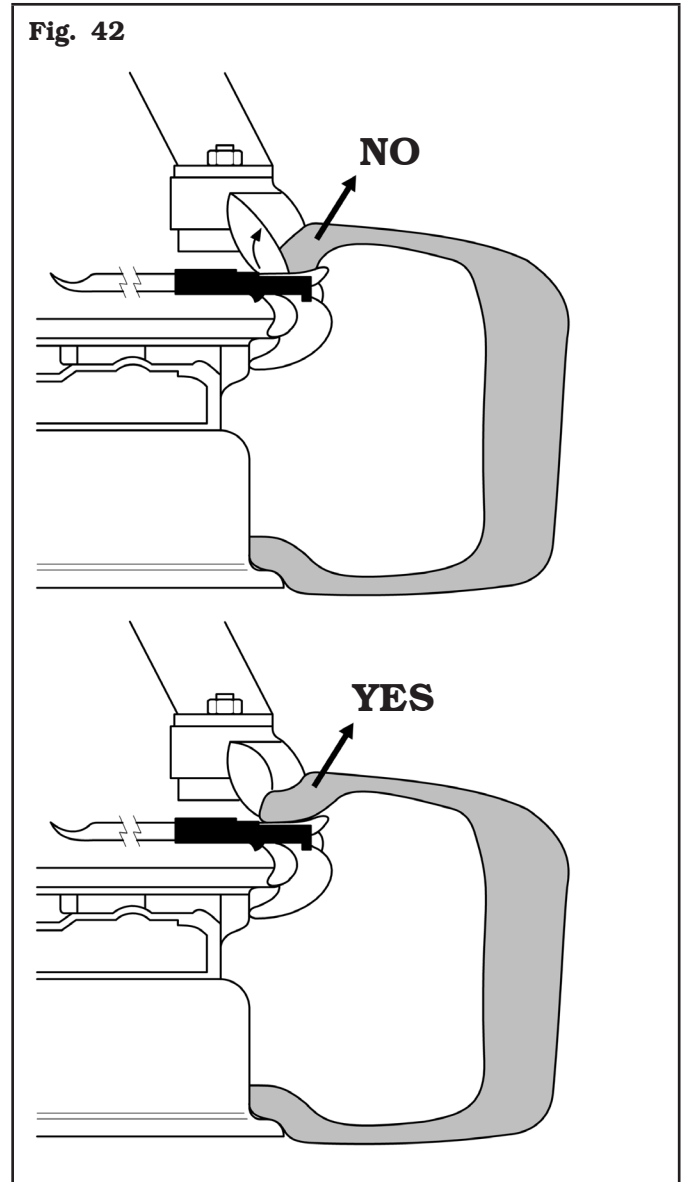

12.9 Tyre disassembly (applies to models with upper and lower bead breaker)

When both beads are broken, the tyre can be demounted:

1. press the pedal to rotate the wheel clockwise until the valve stem reaches "1 o'clock" position;
2. press the push button on the handle and position the mounting/demounting arm on the rim outer edge.

It is important to position the mounting arm correctly (there are 2 possible positions). The two positions are set using the knob on the post and, keeping the push button on the handle pressed, manually moving the arms until they are locked in the desired position. The correct position is achieved when the angle between the tool holder arm and the rim plate is 90° (see Fig. 43).

This position is important because:

- it reduces the tension during mounting/demounting;
- it spreads the force applied to the toolhead over the largest area possible;
- it significantly reduces the wear of the toolhead.

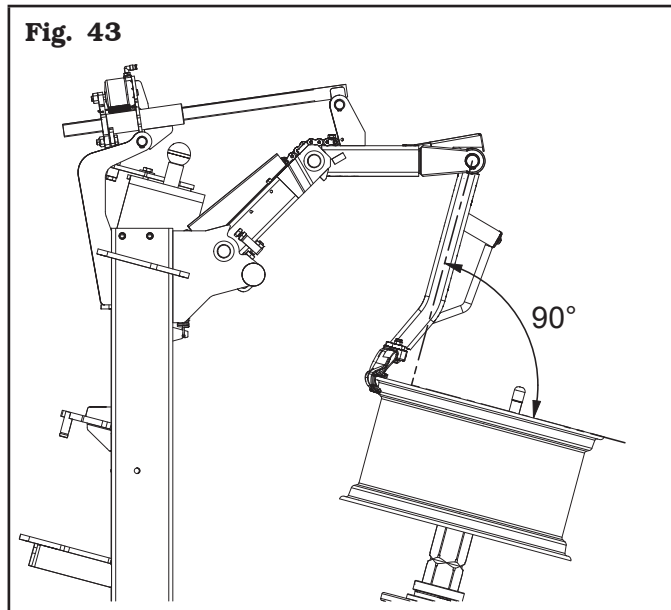

Fig. 43

WITH ROUNDED OR FLAT EDGE RIMS, THE ARM SHOULD HAVE AN ANGLE OF 100°/110°.

3. Move the lever protector to the pointed end of the bead lifting lever. Use the same lever to lift the bead onto the right end of the toolhead and position it parallel with the rim plate at the same time pressing on the side of the tyre at "6 o'clock" position;

4. press the pedal to turn the wheel clockwise until the whole bead has been lifted from the rim. During the rotation of the wheel, the bead lifting tool slides away from the toolhead moving onto the rim edge. The plastic protector prevents the lever from scratching the rim;
5. lift the tyre and repeat the operation on the other bead.

On heavy low-profile tyres, for an easier and safer demounting, once the upper bead has been broken, it is advisable to keep pressing until obtaining enough space to lubricate the drop centre, the bead seating, and the bead itself. (see Fig. 44). Failure to lubricate might cause friction between the toolhead and the tyre, and would cause damage to the tyre and/or the bead.

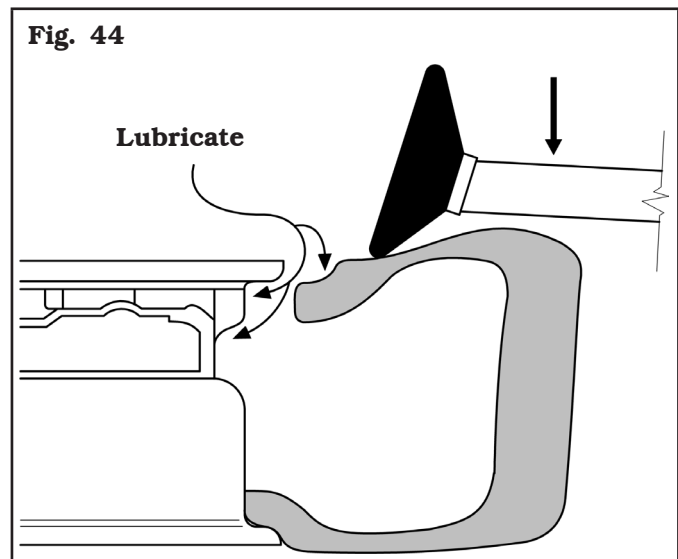

Fig. 44

When the upper bead is being demounted, it might happen that the lower bead re-sets in the rim. In this case use bead breaker lower roller to bead-break again, and if the tyre should be very wide, push it up to the toolhead (see Fig. 45).

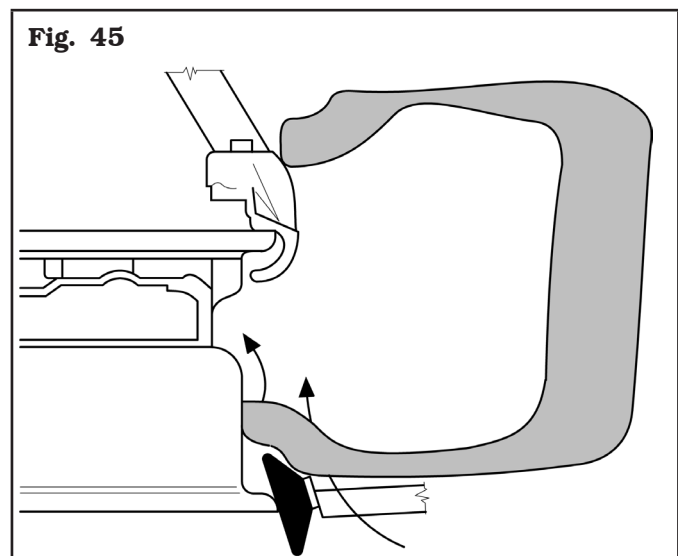
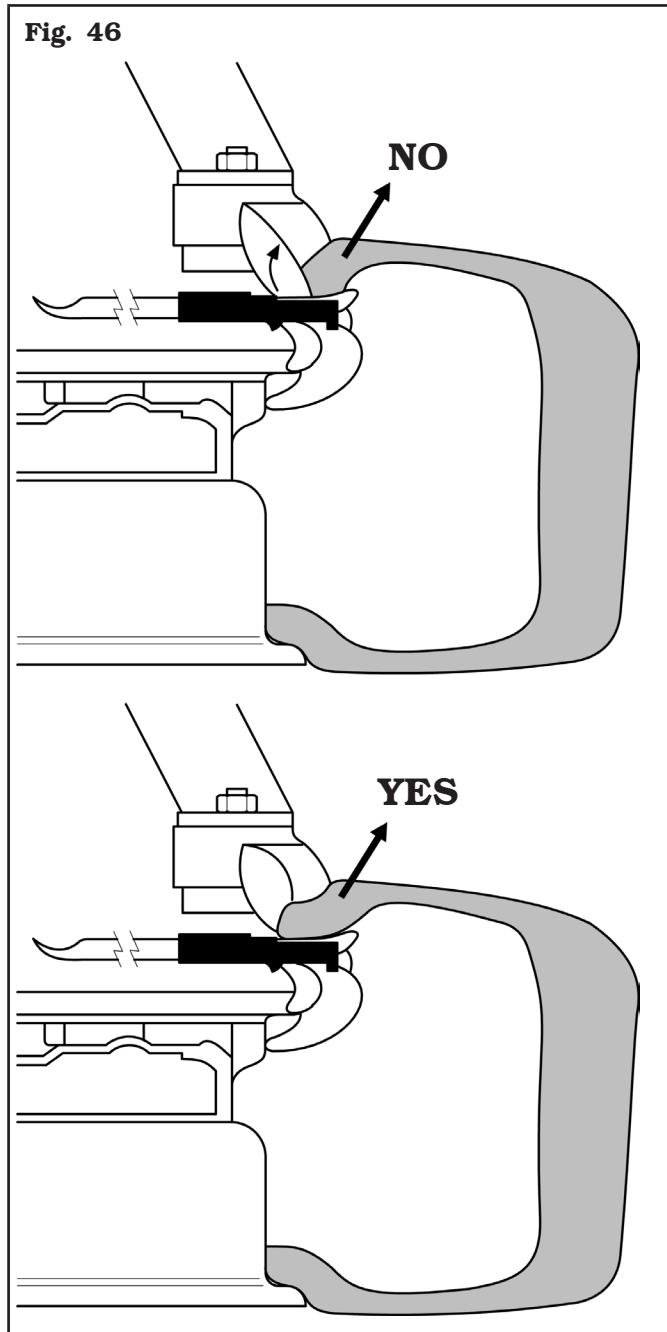
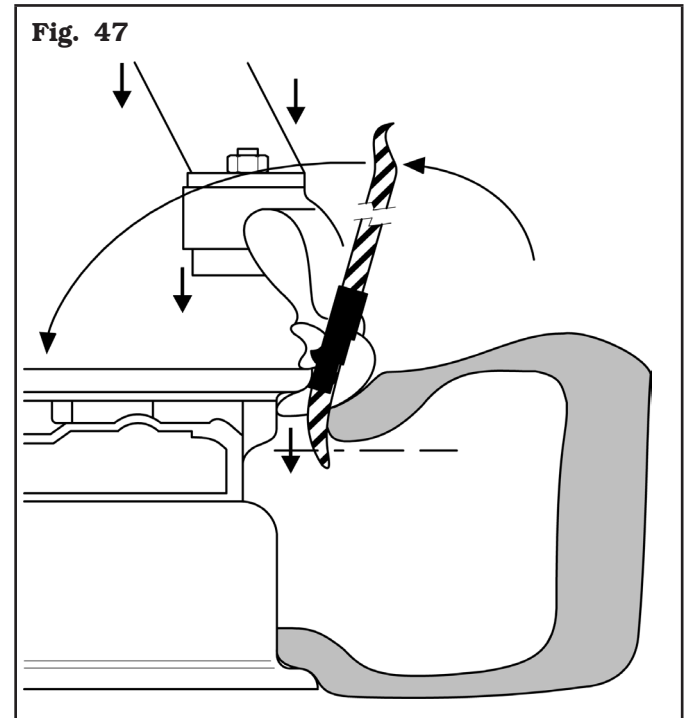

Fig. 45

When demounting hard tyres, the bead may come onto the toolhead with the lip turned. This causes the bead to slide from the lever when clockwise rotation begins. To avoid this problem rotate the wheel slightly anti-clockwise until the problem rotates until the bead flattens. Now the clockwise demounting cycle can begin (see **Fig. 46**).



When demounting hard low-profile tyres, it might happen that the bead pushes the toolhead up. It may be found useful to use the upper bead breaker roller to push the bead down to create enough space to position the lever and at the same time pushing up the tool holder arm down (**Fig. 47**).



If the motor slows down or stops during tyre demounting and mounting, make the following checks:

- check that the bead has been lubricated;
- check that the bead has been pushed into the drop centre;
- check that the right side of the rim has been chosen for demounting or mounting the tyre;
- check that the supply pressure is not below 8 bar (116 psi);
- check that the rim drop centre is not off-centre.

There are rims on the market for which it is difficult to check the position of the drop centre with the tyre mounted. A useful method for checking is to use the bead-breaker rollers, pressing on the tyre sufficiently to see the inside of the rim.

12.10 Demounting the tyre upper bead with the force multiplier (standard on some models)

1. After positioning the bead lifting lever...

Fig. 48



2. ... pull the device lever downwards, until the tool-head comes into contact with the rim edge;

Fig. 49



3. pull the tyre bead over the toolhead with the bead lifting lever;

Fig. 50



4. if the lever does not meet the toothed sector (as shown in the **Fig. 51**), lift the vertical arm slightly (5 - 7 cm / 0.2" - 0.3") until it matches the tothing and then proceed to work.

Fig. 51

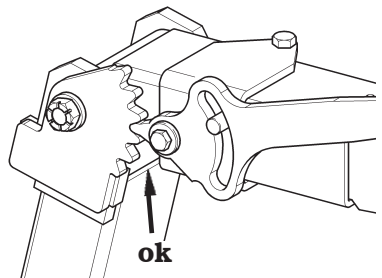
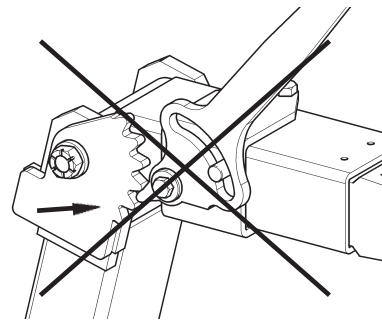

TO OPTIMIZE THE OPERATION OF THE DEVICE, THE TEETH AND THE LEVER MUST BE CORRECTLY POSITIONED.

12.11 Tyre mounting (applies to models with bead press device)

To mount the tyre, proceed as follows:

1. lubricate tyre beads;
2. position the tyre on the rim and lower the arm (after unlocking it with the appropriate command) to place the toolhead on the rim outside edge, checking the inclination;
3. place bead press roller (**Fig. 52 ref. 1**) radially as compared to the rim, as indicated in the figure;
4. lower the bead press roller (**Fig. 52 ref. 1**), by operating button (**Fig. 52 ref. B**) on the control unit, until tyre bead is placed next to the rim drop centre;

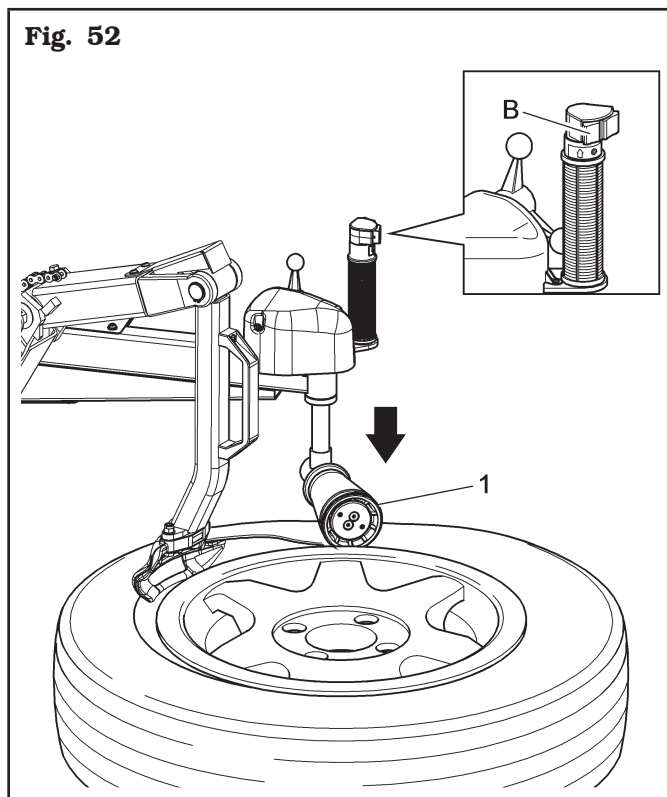

5. position the lower rim edge on the left side of the toolhead and press the pedal to rotate clockwise (**Fig. 53 ref. 1**);



WITH SOME TYPES OF WHEELS (RUN - FLAT TYPE), BEAD PRESS ROLLER MIGHT BE NECESSARY AS MOUNTING AID TOOL. SUCH ACCESSORY IS AVAILABLE ON DEMAND.

6. at the end of the operation lift the bead press device by pushing the relevant button (**Fig. 53 ref. A**) on the control unit. Then finish inserting the second bead by rotating the mandrel clockwise (see **Fig. 53**), taking care to first position the valve stem at the "5-6 o'clock".

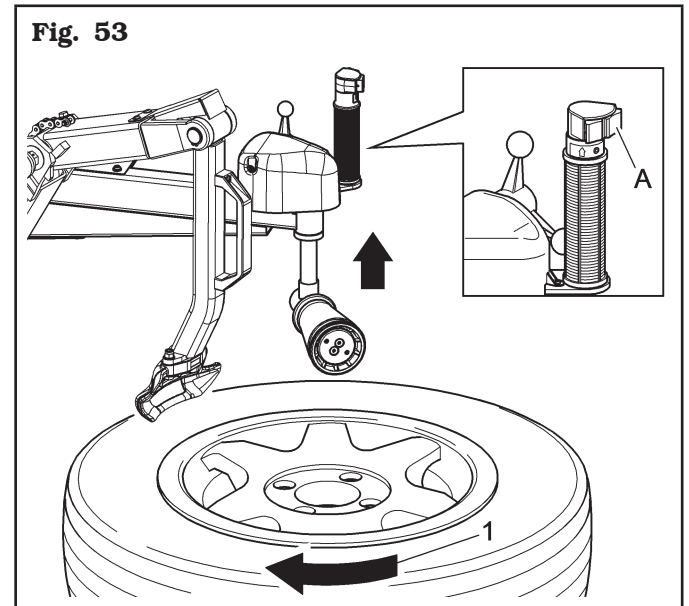

12.12 Tyre assembly (applies to models with upper and lower bead breaker)

To mount the tyre, proceed as follows:

1. lubricate tyre beads;
2. position the tyre on the rim and lower the arm (after unlocking it with the appropriate command) to place the toolhead on the rim outside edge, checking the inclination;
3. position the lower rim edge on the left side of the toolhead and press the pedal to rotate clockwise;
4. repeat the operation on the upper bead, taking care first to position the valve insert at "5-6 o'clock".

Using the upper bead breaker roller to push the bead into the drop centre may help when mounting hard low-profile tyres (see **Fig. 54**).

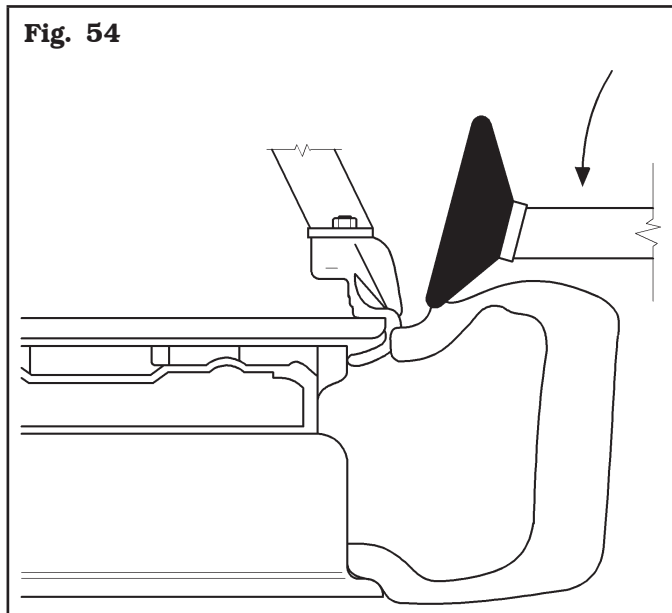

To carry out this operation it is necessary to move the upper bead breaker to work position (the locking knob automatically engages), then move the roller towards the tyre edge, and start the hydraulic pump while simultaneously turning the motor clockwise (see **Fig. 55**).

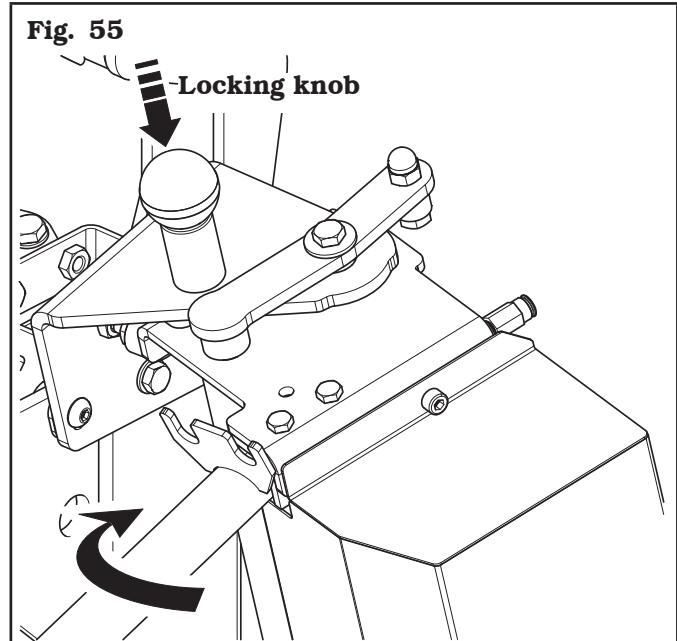

At the end of the operations, lift the locking knob and bring the support of the bead breaker arm to rest position.

12.13 Mounting the tyre upper bead with the beadpusher with pulling system (standard on some models)

1. Assemble the beadpusher with pulling system (Fig. 56 ref. 1) next to the rim edge (see Fig. 56);

Fig. 56

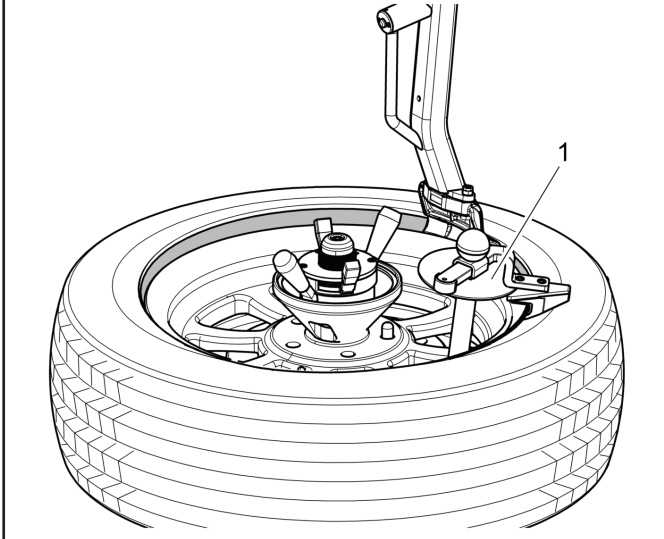

2. place the upper bead breaker roller (Fig. 57 ref. 1) so that the tyre bead is kept at the same height of the rim drop centre (see Fig. 57);



THE BEAD BREAKER DISC MUST EXERT PRESSURE ON THE TYRE BEAD BUT NEVER ON THE RIM.



VERY CAREFULLY USE THE BEAD BREAKER ROLLER IN ORDER TO AVOID POSSIBLE HAND CRUSHING INJURY.

Fig. 57

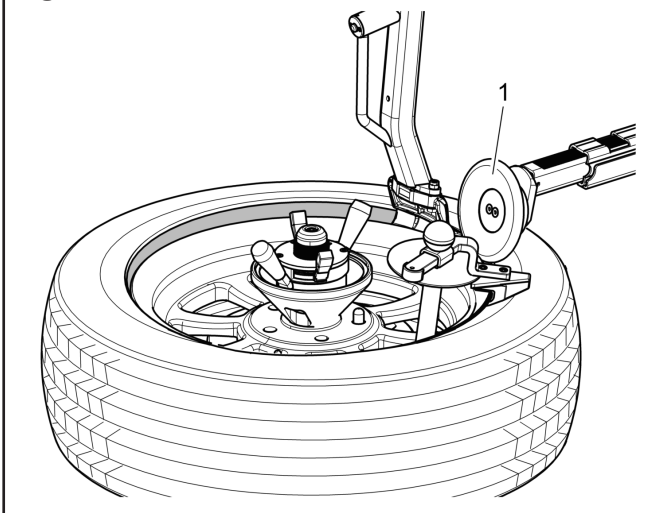

3. rotate clockwise up to tyre complete assembly (see Fig. 58);



FOR THE MOUNTING OF VERY DIFFICULT WHEELS, USE THE EXTENSION OF THE BEADPUSHER (FIG. 58 REF. 1).

Fig. 58

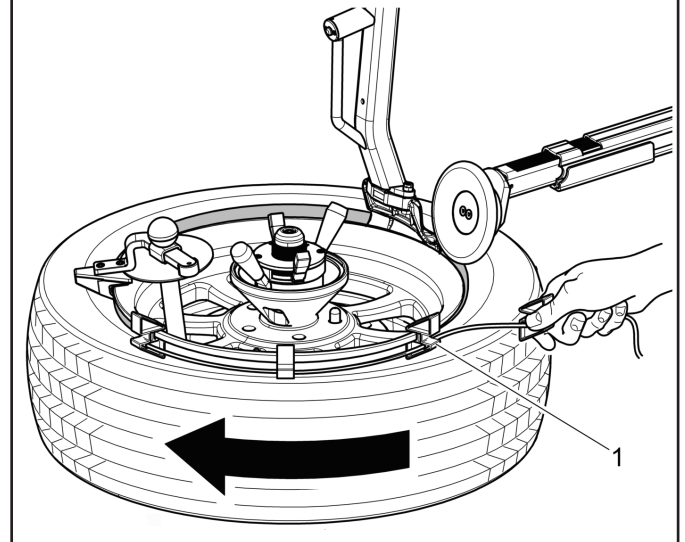

4. when these operations are over move the toolhead and the bead breaker roller into rest position.

12.14 For rims with spoke end raised compared to the rim-edge

Disassembly

1. Clamp the wheel (preventively deflate the tyre completely and remove the balancing counterweights on both sides of the wheel);
2. carry out tyre bead breaking with the standard procedure;
3. use the upper bead breaker roller to lubricate with an approved lubricant the tyre bead, the lip, the bead seat and the EDGE of the RIM;
4. position the tool arm on the edge of the rim. Move forward the toolhead so that it penetrates between the rim and the tyre. While this operation is being performed, the toolhead rotates around the rim edge until it hooks the tyre bead;
5. raise the lower bead breaker roller to reduce the tension of the tyre on the toolhead;
6. rotate the wheel in clockwise direction pushing the pedal provided;
7. with the lever lift the lower bead onto the toolhead and rotate in clockwise direction in order to complete demounting.

Assembly

1. Lubricate both tyre-beads with an approved lubricant;
2. lubricate the inner part of the toolhead and also the rim edge;
3. complete mounting procedure following the standard procedure.

12.15 Special use of the upper and lower bead breaker (standard on some models)

In addition to its use during mounting and demounting, the bead-breakers can also be used for matching the tyre to the rim.

To conduct this operation carry out the following instructions:

1. clamp the tyre between the bead breaker rollers;
2. turn the motor counter-clockwise until the reference point on the tyre coincides with the reference point on the rim (usually the valve) (see **Fig. 59**).

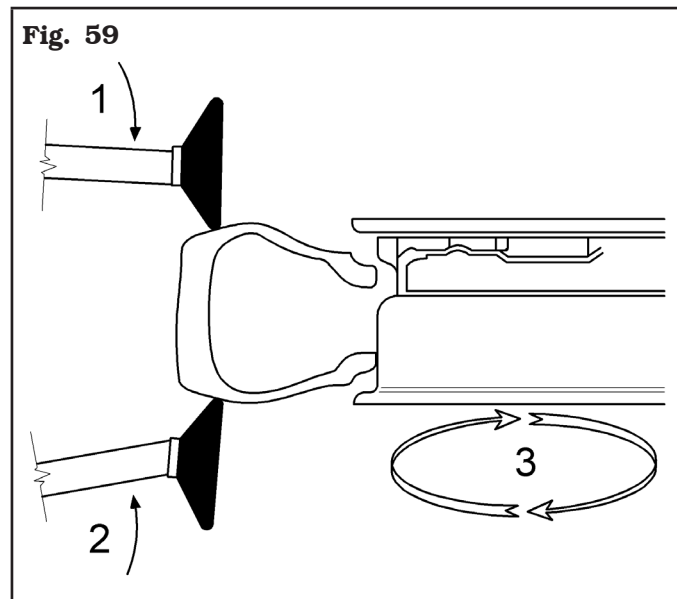

12.16 Inflation



TYRE INFLATING OPERATIONS ARE HAZARDOUS FOR THE OPERATOR; MOREOVER, IF NOT PROPERLY EXECUTED, THEY CAN CAUSE DAMAGE TO THE USERS OF THE VEHICLE WHERE THE TYRES ARE FITTED.



STANDARD OR OPTIONAL INFLATING UNITS FITTED ON TYRE CHANGERS ARE ALWAYS EQUIPPED WITH A PRESSURE LIMITING DEVICE WHICH ELIMINATES ANY RISK OF TYRE EXPLOSION DURING TYRE INFLATION. HOWEVER, A RESIDUAL RISK OF EXPLOSION STILL EXISTS. THE FOLLOWING PRECAUTIONS MUST BE TAKEN:

- **OPERATORS SHOULD WEAR SUITABLE PROTECTIVE CLOTHING LIKE: GLOVES, SAFETY EYEWEAR AND EARPLUGS.**
- **BEFORE FITTING A TYRE, CHECK TYRE AND RIM CONDITIONS AS WELL AS THEIR PROPER COUPLING.**
- **CORRECT WORK POSITION: DURING TYRE BEADING AND INFLATING THE OPERATOR MUST KEEP HIS BODY AS FAR AS POSSIBLE FROM THE TYRE.**
- **COMPLIANCE WITH TYRE MANUFACTURER'S SPECIFICATIONS FOR TYRE INFLATION PRESSURE.**



If measured pressure exceeds 4.2 BAR (60 PSI), IT MEANS THAT THE PRESSURE LIMITING VALVE AND/OR PRESSURE GAUGE IS NOT WORKING PROPERLY. IN THIS CASE, DEFLATE THE TYRE ON THE SPOT AND CONTACT AN AUTHORIZED SERVICE CENTRE TO VERIFY EQUIPMENT OPERATION. MAKE SURE OF PROPER OPERATION BEFORE USING ANY INFLATING EQUIPMENT.

12.16.1 Tyre inflation

Connect the inflation device to the tyre valve and inflate the tyre itself by operating the appropriate pedal (**Fig. 24 ref. 1**) (applies to models with inflation pedal) or by pressing the lever on the gun (**Fig. 1 ref. 7**) (applies to model with inflation gun).



A SAFETY DEVICE IS PRESENT FOR THE ADJUSTMENT OF THE MAXIMUM PRESSURE OF THE SUPPLIED AIR (4.2 ± 0.2 bar / 60 ± 3 psi).

Well lubricated beads and rims make the beading in and inflation much safer and easier.

In case the beads are not seated at 4.2 ± 0.2 bar (60 ± 3 psi), release all the air from the wheel, remove it from the tyre changer and put it in a safety cage to complete the inflation procedure.

13.0 ROUTINE MAINTENANCE



BEFORE CARRYING OUT ANY ROUTINE MAINTENANCE OR ADJUSTMENT PROCEDURE, DISCONNECT THE EQUIPMENT FROM THE ELECTRICITY SUPPLY USING THE SOCKET/PLUG COMBINATION AND CHECK THAT ALL MOBILE PARTS ARE AT A STANDSTILL.



BEFORE EXECUTING ANY MAINTENANCE OPERATION, MAKE SURE THERE ARE NO WHEELS LOCKED ONTO THE SELF-CENTRING CHUCK.



To guarantee the efficiency and correct functioning of the equipment, it is essential to carry out daily or weekly cleaning and weekly routine maintenance, as described below.

Cleaning and routine maintenance must be conducted by authorized personnel and according to the instructions given below.

- Disconnect the equipment from the electrical and pneumatic power supplies before carrying out any cleaning operations.
- Remove deposits of tyre powder and other waste materials with a vacuum.

DO NOT BLOW IT WITH COMPRESSED AIR.

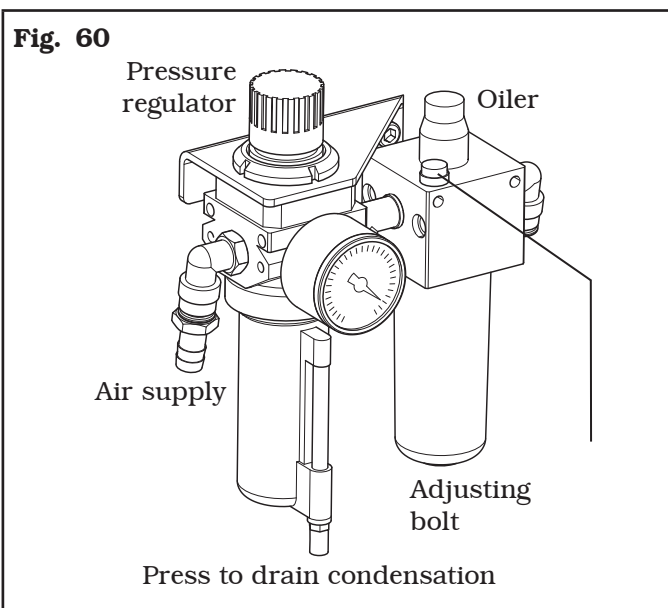
- Do not use solvents to clean the pressure regulator.
- The condensation in the pressure regulator reservoir must be drained **daily**. Press the fitting at the bottom of the regulator to discharge the water. (see **Fig. 60**).
- Periodically check the calibration of lubricator of pressure/oiler gauge assembly:

IN ORDER TO ALLOW A LONGER LIFE OF THE FILTER AND OF ALL MOVING PNEUMATIC DEVICES, YOU HAVE TO MAKE SURE THAT THE SUPPLIED AIR IS:



- EXEMPT FROM THE LUBRICATING OIL OF THE COMPRESSOR;
- EXEMPT FROM HUMIDITY;
- EXEMPT FROM IMPURITY.

- Every **week** and/or when necessary, top up the oil tank using the filler hole provided, closed by a cap or bolt, on the lubricator filter.

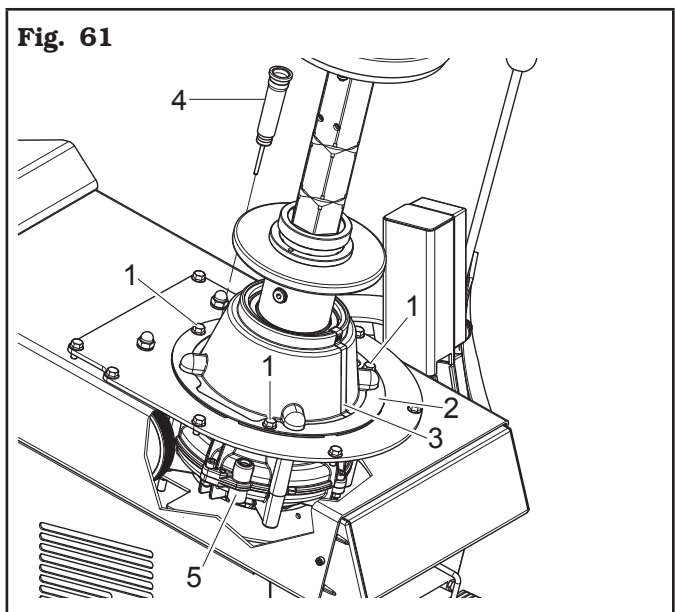

THIS OPERATION SHOULD NOT BE CARRIED OUT BY REMOVING THE CUP OF THE LUBRICATOR FILTER.

- The use of synthetic oil might damage the pressure regulator filter.
- Replace immediately worn out parts, lever protector, bead breaker rollers (standard on some models) toolhead, rubber pads (applies to models with self-centring chuck).
- Periodically (at least every 100 working hours) check reduction gear lubricating oil level (**Fig. 61 ref. 5**). Such operation must be performed removing the bolts (**Fig. 59 ref. 1**), removing the flange (**Fig. 61 ref. 2**), the guard (**Fig. 61 ref. 3**) and the plug (**Fig. 61 ref. 4**) on the reduction gear (applies to model with flat chuck).

ANY DAMAGE TO THE MACHINE DEVICES RESULTING FROM THE USE OF LUBRICANTS OTHER THAN THOSE RECOMMENDED IN THIS MANUAL WILL RELEASE THE MANUFACTURER FROM ANY LIABILITY!!

14.0 TROUBLESHOOTING TABLE







Possible troubles which might occur to the tyre-changer are listed below. The manufacturer disclaims all responsibility for damages to people, animals or objects due to improper operation by non-unauthorised personnel. In case of trouble, call Technical Service Department for instructions on how to service and/or adjust the machine in full safety to avoid any risk of damage to people, animals or objects.





In an emergency and before maintenance on tyre-changer, set the main switch to "0" and lock it in this position.



CONTACT AUTHORIZED TECHNICAL SERVICE

do not try and service alone

Problem	Possible cause	Remedy
The upper bead breaker arm remains down (applies to models with upper and lower bead breaker)	Compressed air supply pressure below 6 bar.	Check supply pressure. Call for technical assistance. 
The bead breaker hydraulic pump jams (applies to models with upper and lower bead breaker)	The bead-breaker lubricator is empty.	Top up the reservoir with suitable oil having first disconnected the power supply. Call for technical assistance. 
The nozzle doesn't supply air when the inflation pedal is pressed (applies to models with inflation pedal).	The inflation pedal is badly adjusted.	Call for technical assistance. 
During bead-breaking the bead breaker shovel does not engage.	<ol style="list-style-type: none"> 1. The arm valve is not activated. 2. The arm valve is badly adjusted. 3. The connection cylinder is broken. 	<ol style="list-style-type: none"> 1. Move the bead-breaker tool out. 2. Call for technical assistance. 3. Call for technical assistance. 
No movements take place when the pedals are pressed.	<ol style="list-style-type: none"> 1. Power supply missed. 2. Inflation pedal unit not set correctly. 	<ol style="list-style-type: none"> 1. Check power supply. 2. Call for technical assistance. 
The chuck doesn't rotate.	Inverter overload alarm Or Inverter undervoltage alarm Or Inverter overvoltage alarm	Shorten the length of a possible equipment extension cable or increase the conductors section (disconnect and connect again). Lift the motor pedal and wait for the automatic reset.
	Overtemperature alarm.	Wait until the motor system cools (the equipment does not restart if the temperature level does not go below the set safety threshold).
The chuck does not reach the maximum rotation speed.	The mechanical resistance of the gearmotor system has increased.	Turn the chuck without wheel for a few minutes so that the system heats, thus reducing frictions. If in the end the chuck does not accelerate again, call for technical assistance. 

Problem	Possible cause	Remedy
The chuck does not turn in the clockwise or counter clockwise direction in one of the allowed speed.	Microswitch breakage.	Check cables <i>or</i> replace microswitch. 
The chuck rotates slowly but it does not operate on the motor pedal.	Pedalboard reversible de-calibration.	<ol style="list-style-type: none"> 1. Keep the pedal to rest position. 2. Keep the equipment connected to the net. 3. Wait for 30 seconds that the pedalboard recalibration automatic attempt ends.
The chuck doesn't rotate, but it attempts rotation when the equipment is switched on again.	Pedalboard irreversible de-calibration.	Contact assistance. 
The chuck does not hold/do not lock the wheel (applies to models with self-centring chuck).	<ol style="list-style-type: none"> 1. Compressed air supply pressure below 6 bar (87 psi). 2. A self-centring chuck component has broken. 3. The pedalboard is badly adjusted. 	<ol style="list-style-type: none"> 1. Check supply pressure. 2. Call for technical assistance. 3. Call for technical assistance. 
The chuck turns but the self-centring chuck does not open/close (applies to models with self-centring chuck).	Brake pneumatic valve breakage.	<ol style="list-style-type: none"> 1. Check air hoses. 2. Replace the valve.
No movement is produced when the control buttons are operated (applies to models with bead press device).	<ol style="list-style-type: none"> 1. Power supply missing. 2. The supply hoses have not been correctly assembled. 3. The control valve is not working. 	<ol style="list-style-type: none"> 1. Check power supply. 2. Check hoses fitting. 3. Call for technical assistance. 
When the control button is operated, movement arises in one direction only (applies to models with bead press device).	The control valve is not working.	Call for technical assistance. 

15.0 TECHNICAL DATA

15.1 Technical electrical data

Motor power (kW)	0.75 (1 Hp)	
Inverter motor power (kW)	1.5 (2 Hp)	
Power supply	Voltage (V)	200 - 240
	Phases	1
	Frequency (Hz)	50 - 60
Typical current draw (A)	10	
Chuck rotation speed (rev/min)	0 - 13	

15.2 Technical mechanical data

	ROT. CLASS.201713	ROT. CLASS.200440	ROT. COMBI.201706	ROT. COMBI.200525	RAV. G1001.200815	RAV. G1065.200792
Tyre max. diameter (inches)	45			47	45	
Rim locking diameter (inches)	12 - 24					
Wheel max. width (inches)	17	15	17	15		
Bead-breaking force at 10 bar (145 psi) (N)	19000 (4190 lbs)					
Operating pressure (bar)	8 - 10 (116 - 145 psi)					

	ROT. CLASS.201713	ROT. CLASS.200440	ROT. COMBI.201706	ROT. COMBI.200525	RAV. G1001.200815	RAV. G1065.200792
Weight (kg)	250 (551 lbs)	257 (566 lbs)	266 (587 lbs)	274 (604 lbs)	243 (536 lbs)	269 (593 lbs)

15.3 Dimensions

Applies to ROT.CLASS.201713 - ROT.CLASS.200440 - RAV.G1001.200815 models

Fig. 62

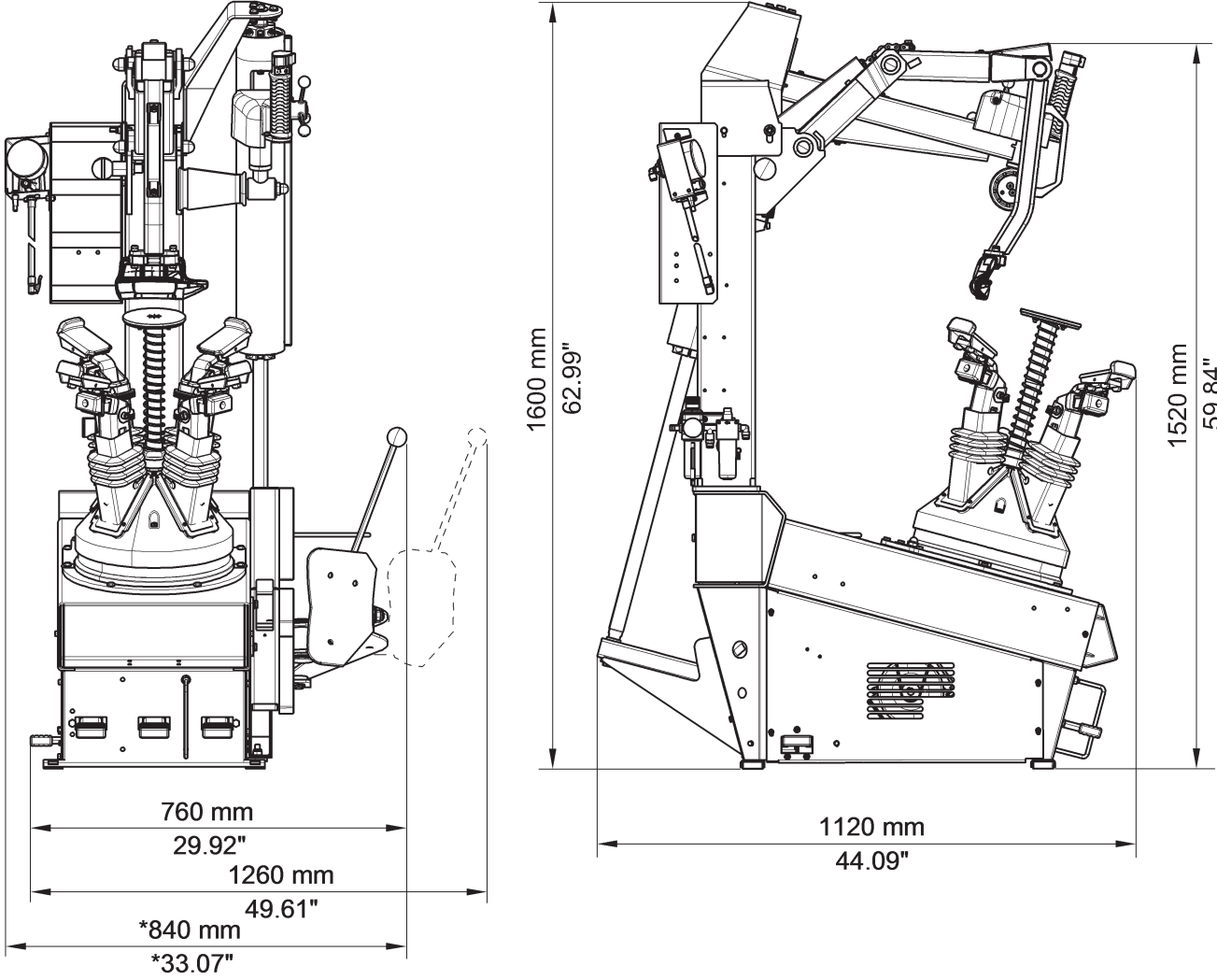

* applies to model with inflation pressure gauge

Applies to ROT.COMBI.201706 - ROT.COMBI.200525 models

Fig. 63

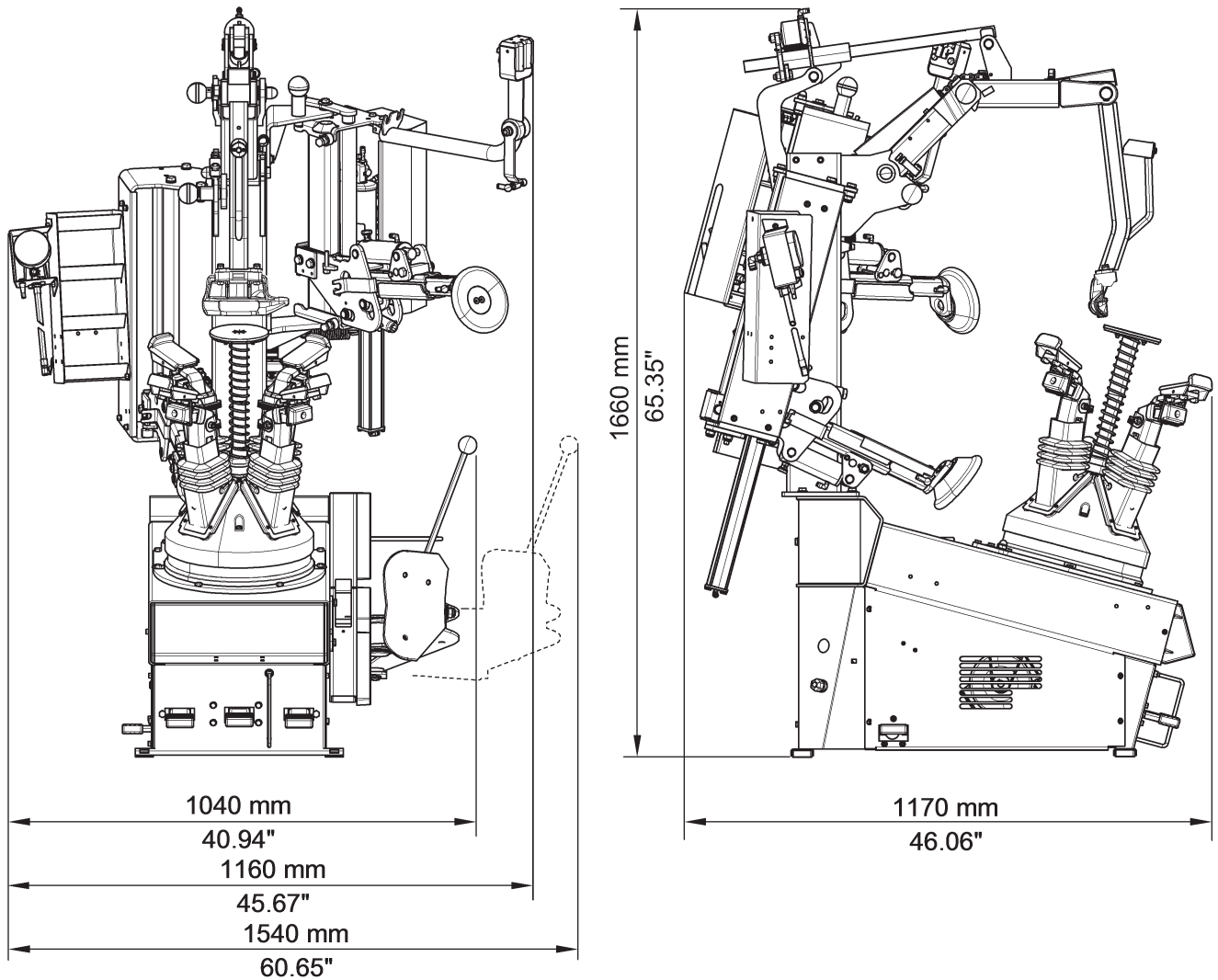

Applies to RAV.G1065.200792 model

Fig. 64

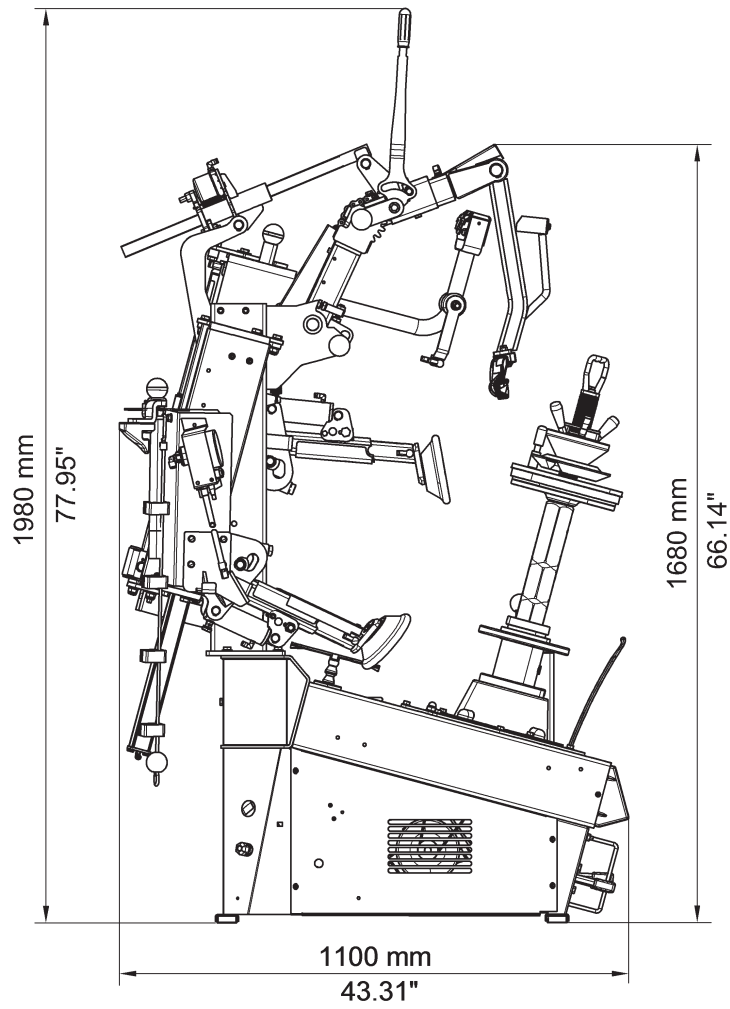
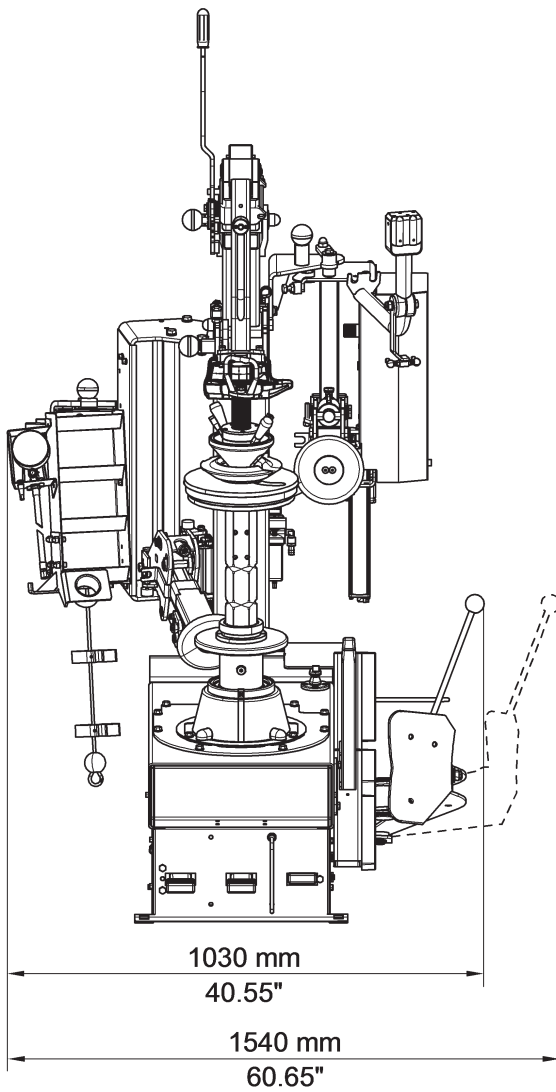

16.0 STORING

If storing for long periods disconnect the main power supply and take measures to protect the equipment from dust build-up. Lubricate parts that could be damaged from drying out. When putting the equipment back into operation replace the rubber pads and the toolhead.

17.0 SCRAPPING

When the decision is taken not to make further use of the equipment, it is advisable to make it inoperative by removing the connection pressure hoses. The equipment is to be considered as special waste and should be dismantled into homogeneous parts. Dispose of it in accordance with current legislation.

Instructions for the correct management of waste from electric and electronic equipment (WEEE) according to the Italian legislative decree 49/14 and subsequent amendments.

In order to inform the users on the correct way to dispose the equipment (as required by the article 26, paragraph 1 of the Italian legislative decree 49/14 and subsequent amendments), we communicate what follows: the meaning of the crossed dustbin symbol reported on the equipment indicates that the product must not be thrown among the undifferentiated rubbish (that is to say together with the "mixed urban waste"), but it has to be managed separately, to let the WEEE go through special operations for their reuse or treatment, in order to remove and dispose safely the waste that could be dangerous for the environment and to extract and recycle the raw materials to be reused.

Fig. 65

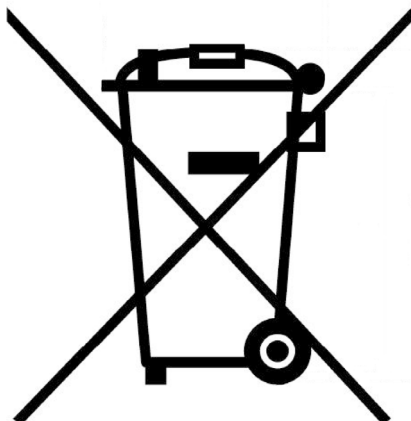

18.0 REGISTRATION PLATE DATA

TYRE CHANGER MODEL	SERIAL N°	MONTH-YEAR
AMPERAGE	BAR	POWER SUPPLY

The validity of the Conformity Declaration enclosed to this manual is also extended to products and/or devices the equipment model object of the Conformity Declaration can be equipped with. Said plate must always be kept clean from grease residues or filth generally.



ATTENTION: TAMPERING WITH, CARVING, CHANGING ANYHOW OR EVEN REMOVING EQUIPMENT IDENTIFICATION PLATE IS ABSOLUTELY FORBIDDEN; DO NOT COVER IT WITH TEMPORARY PANELS, ETC., SINCE IT MUST ALWAYS BE VISIBLE.

WARNING: Should the plate be accidentally damaged (removed from the equipment, damaged or even partially illegible) inform immediately the manufacturer.

19.0 FUNCTIONAL DIAGRAMS

Here follows a list of the equipment functional diagrams.

1PH POWER SUPPLY CABLE 2P+GROUND x 6 mmq

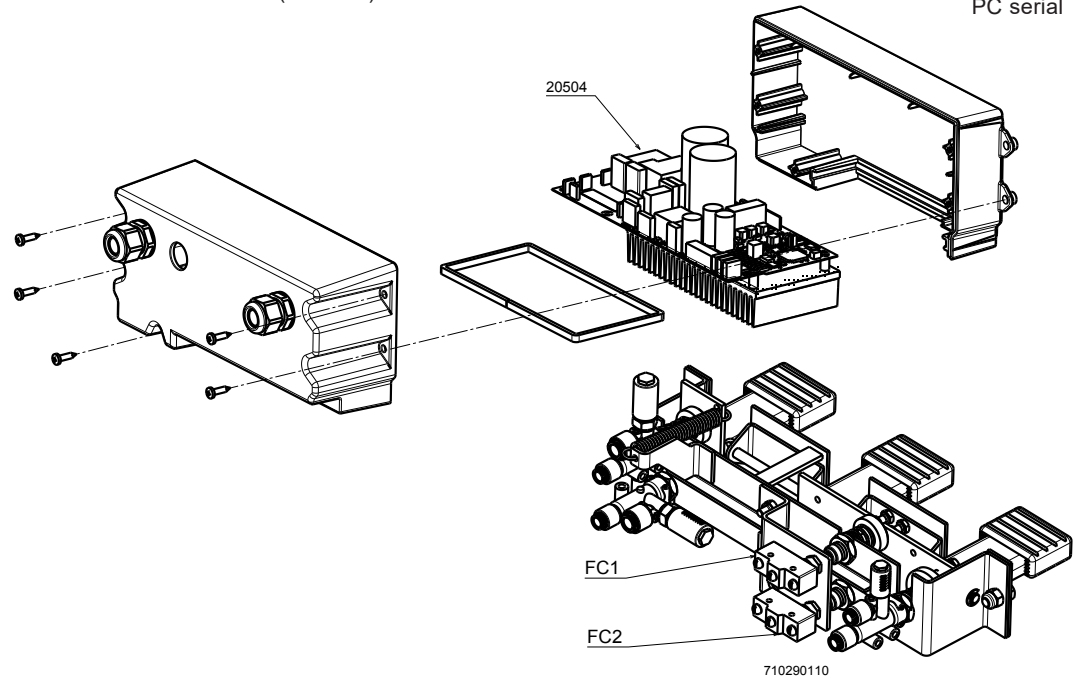
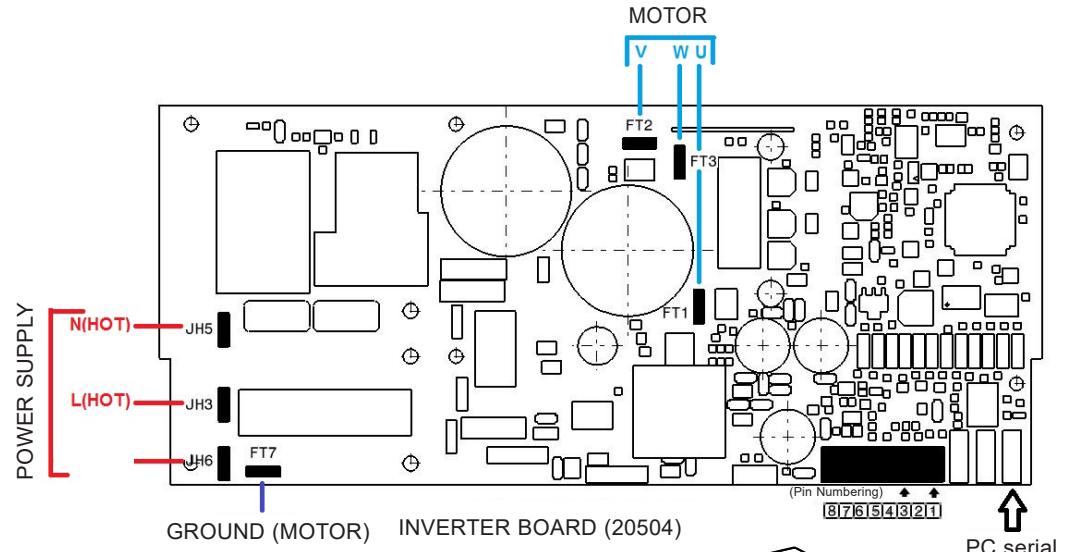
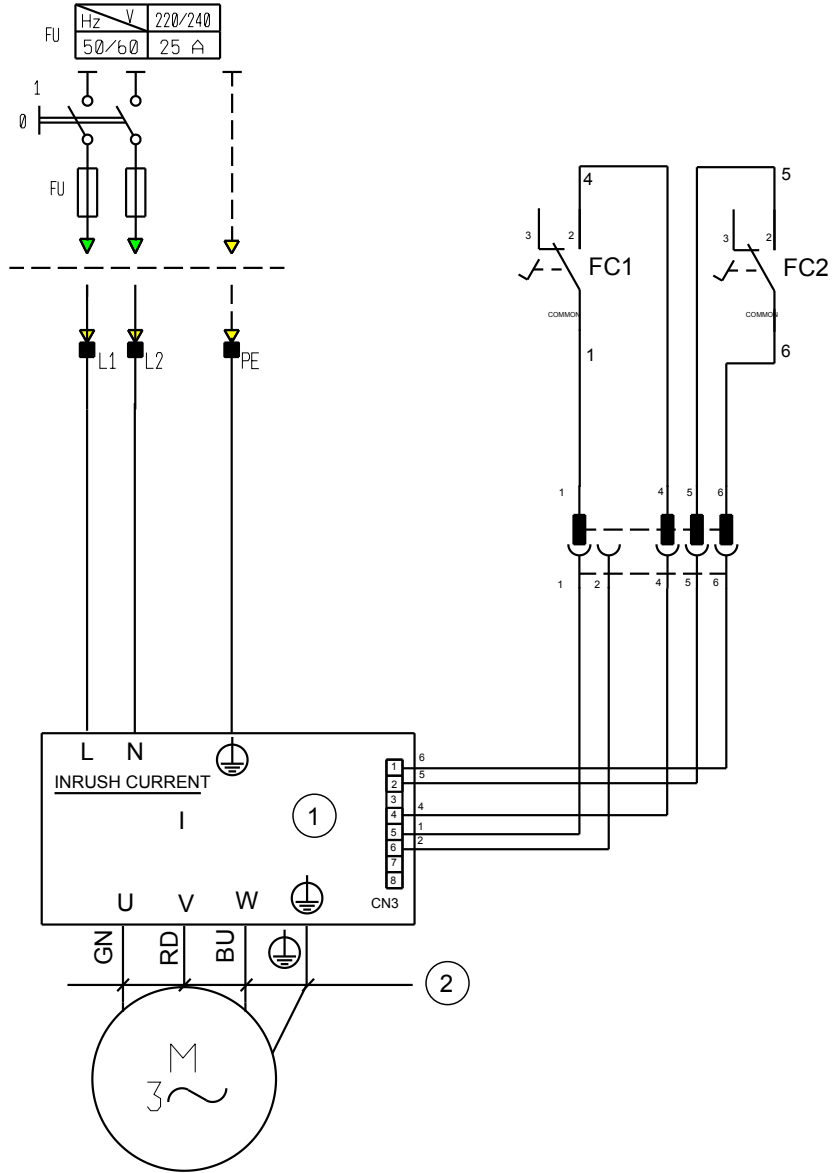

LIST OF COMPONENTS	
Drawing N°A - Rev. 0	710205601

WIRING DIAGRAM
 (APPLIES TO ROT.CLASS.201713 -
 ROT.CLASS.200440 - RAV.G1001.200815 MODELS)

1PH POWER SUPPLY CABLE 2P+GROUND x 6 mmq

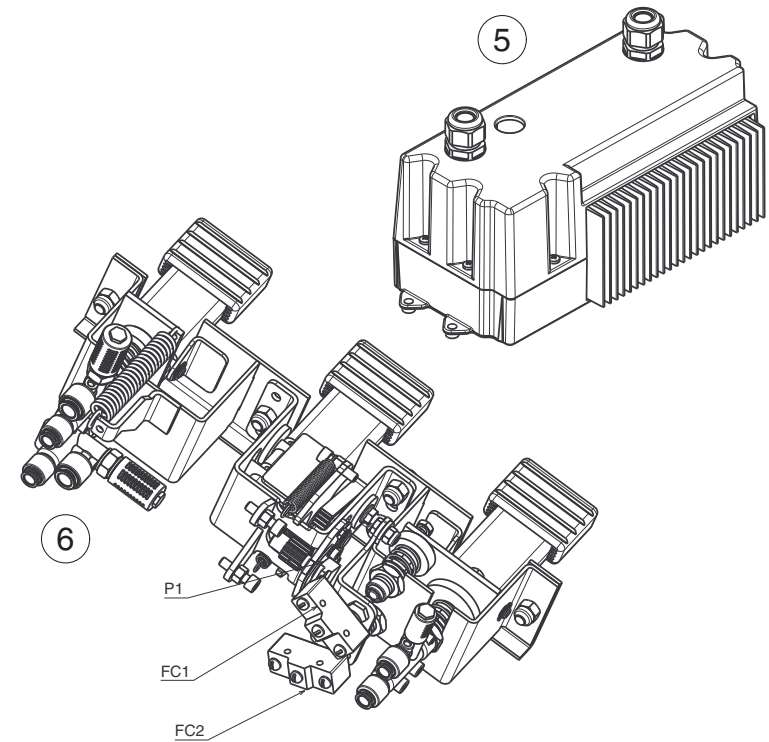
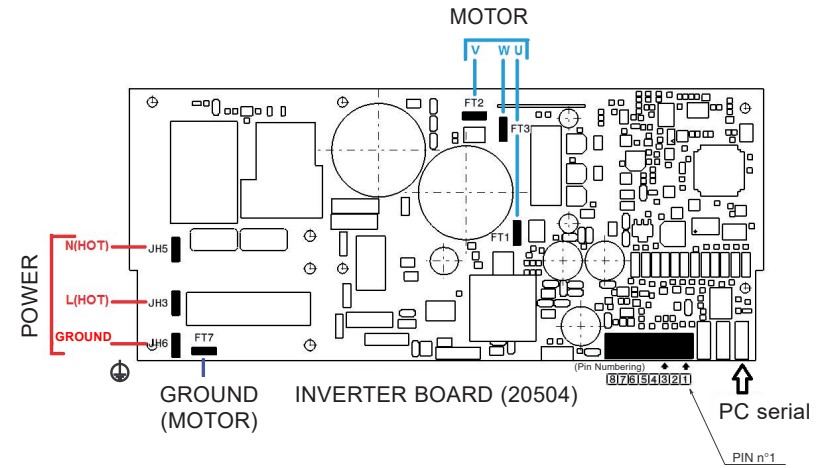
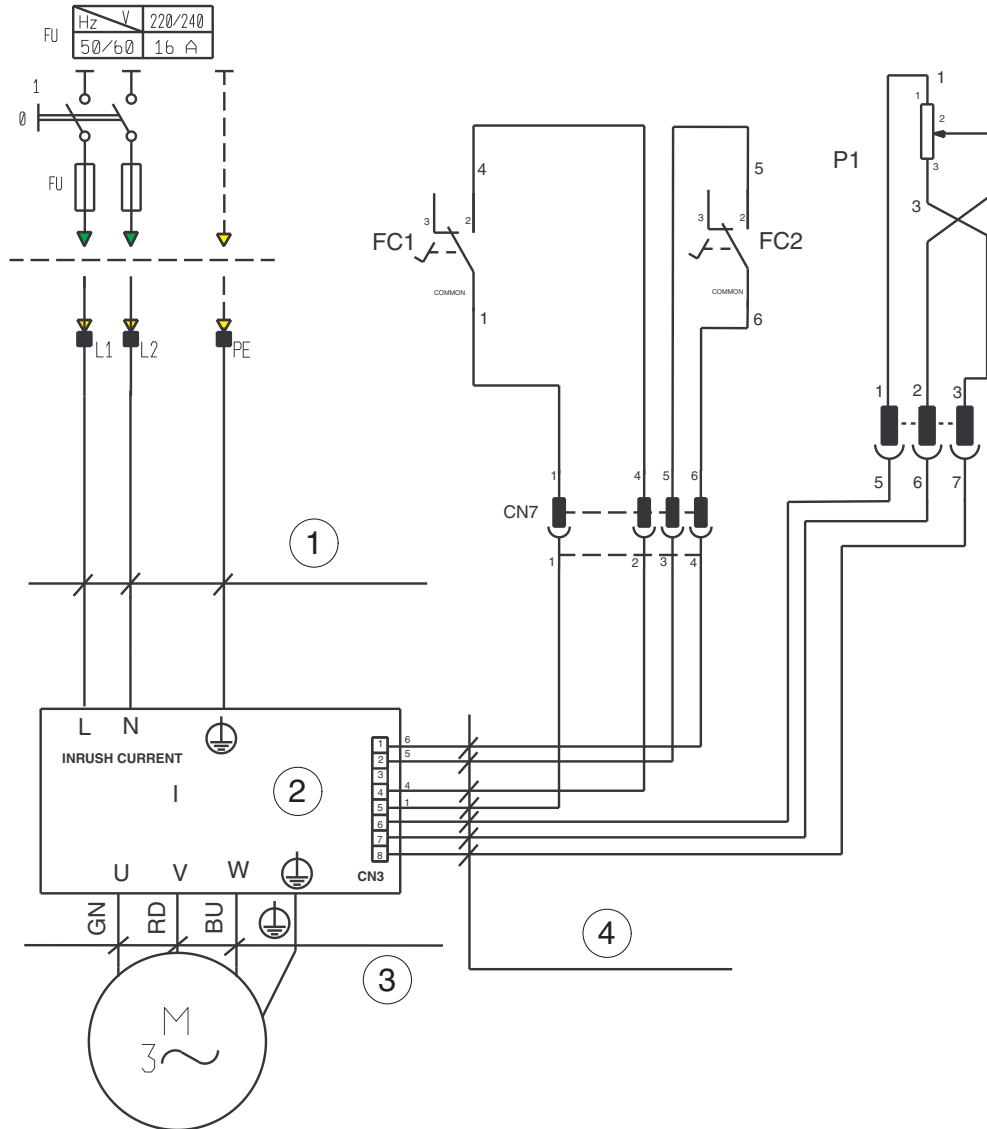

LIST OF COMPONENTS

Drawing N°B - Rev. 0

710205591

WIRING DIAGRAM
(APPLIES TO ROT.COMBI.201706 - ROT.COMBI.200525
MODELS)

Page 59 of 71

TYRE-CHANGER SERIES
CLASSIC - COMBI - G1001 - G1065

1PH POWER SUPPLY CABLE 2P+GROUND x 6 mmq

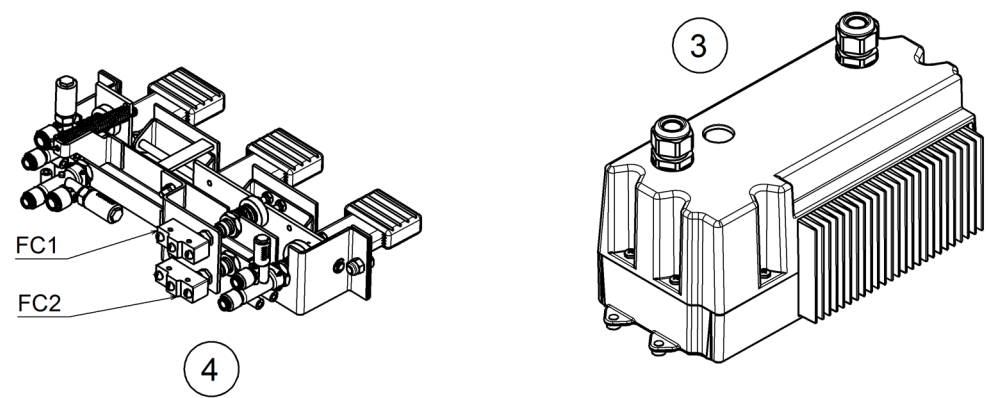
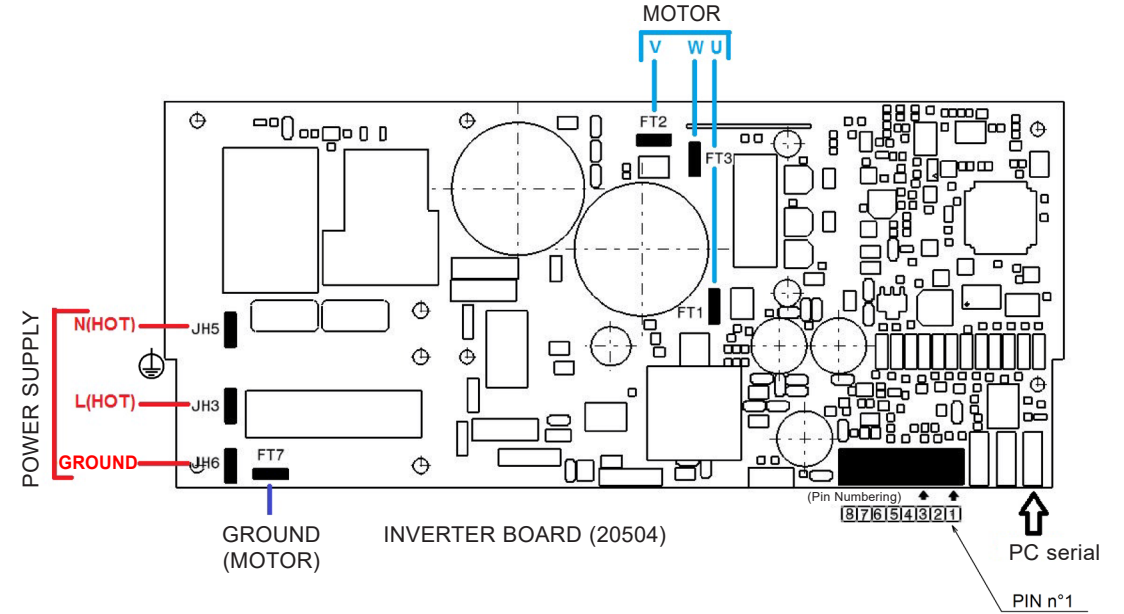
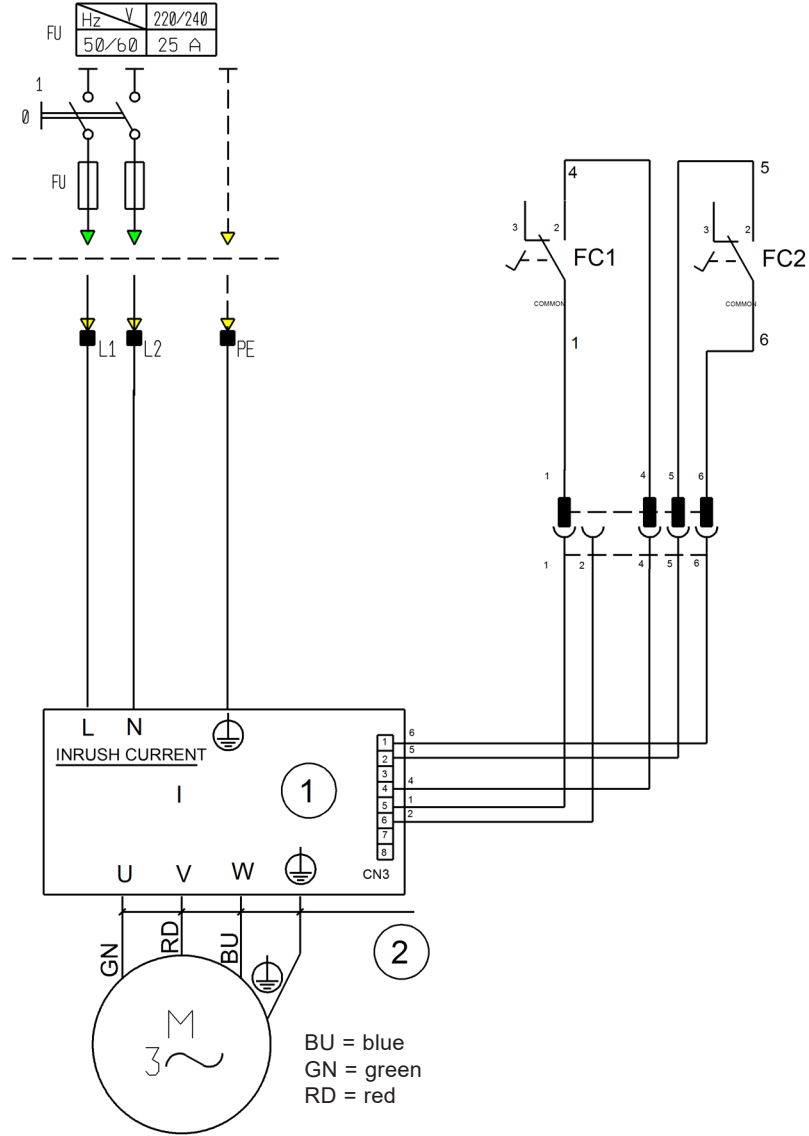

	LIST OF COMPONENTS		WIRING DIAGRAM (APPLIES TO RAV.G1065.200792 MODEL)	Page 61 of 71
	Drawing N°C - Rev. 0	710205554		TYRE-CHANGER SERIES CLASSIC - COMBI - G1001 - G1065

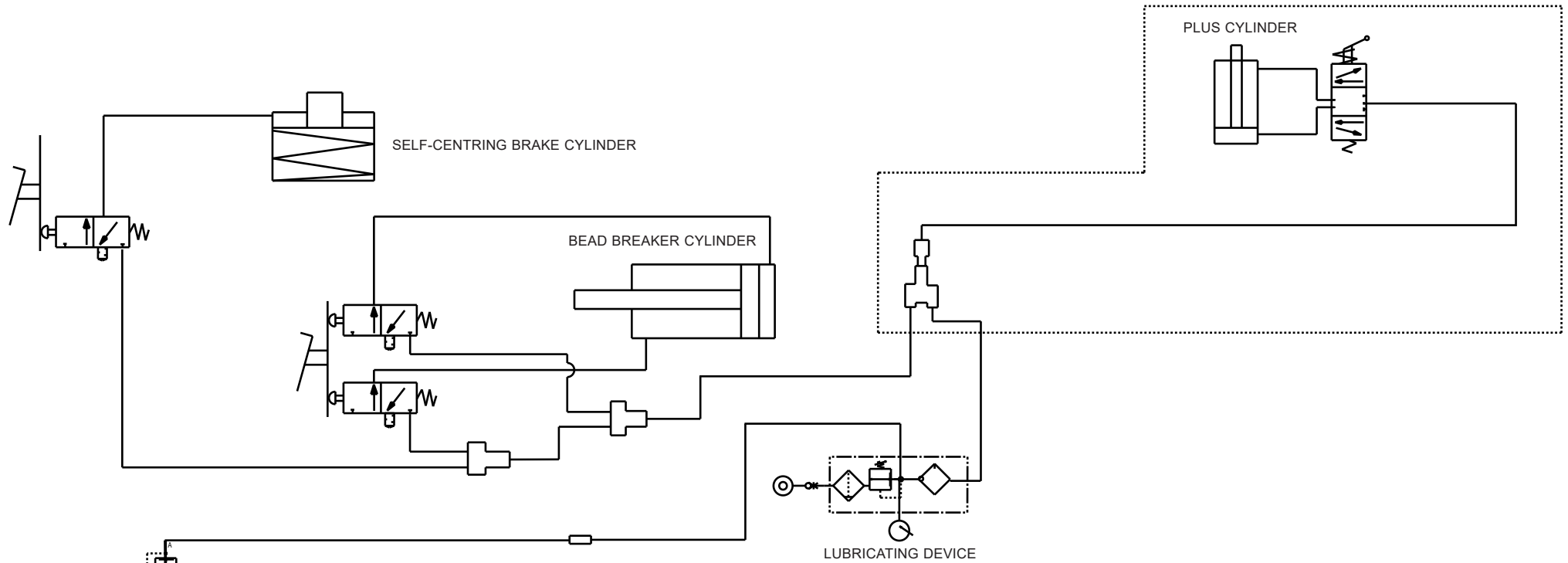

INFLATION SYSTEM	
TYPE OF INFLATION: GUN EQUIPMENT ROT.G1001	TYPE OF INFLATION: PEDAL EQUIPMENT ROT.CLASS
<p>INFLATION GUN</p>	



LIST OF COMPONENTS	
Drawing N°D - Rev. 0	710205211

PNEUMATIC DIAGRAM
 (APPLIES TO ROT.CLASS.201713 -
 ROT.CLASS.200440 - RAV.G1001.200815 MODELS)

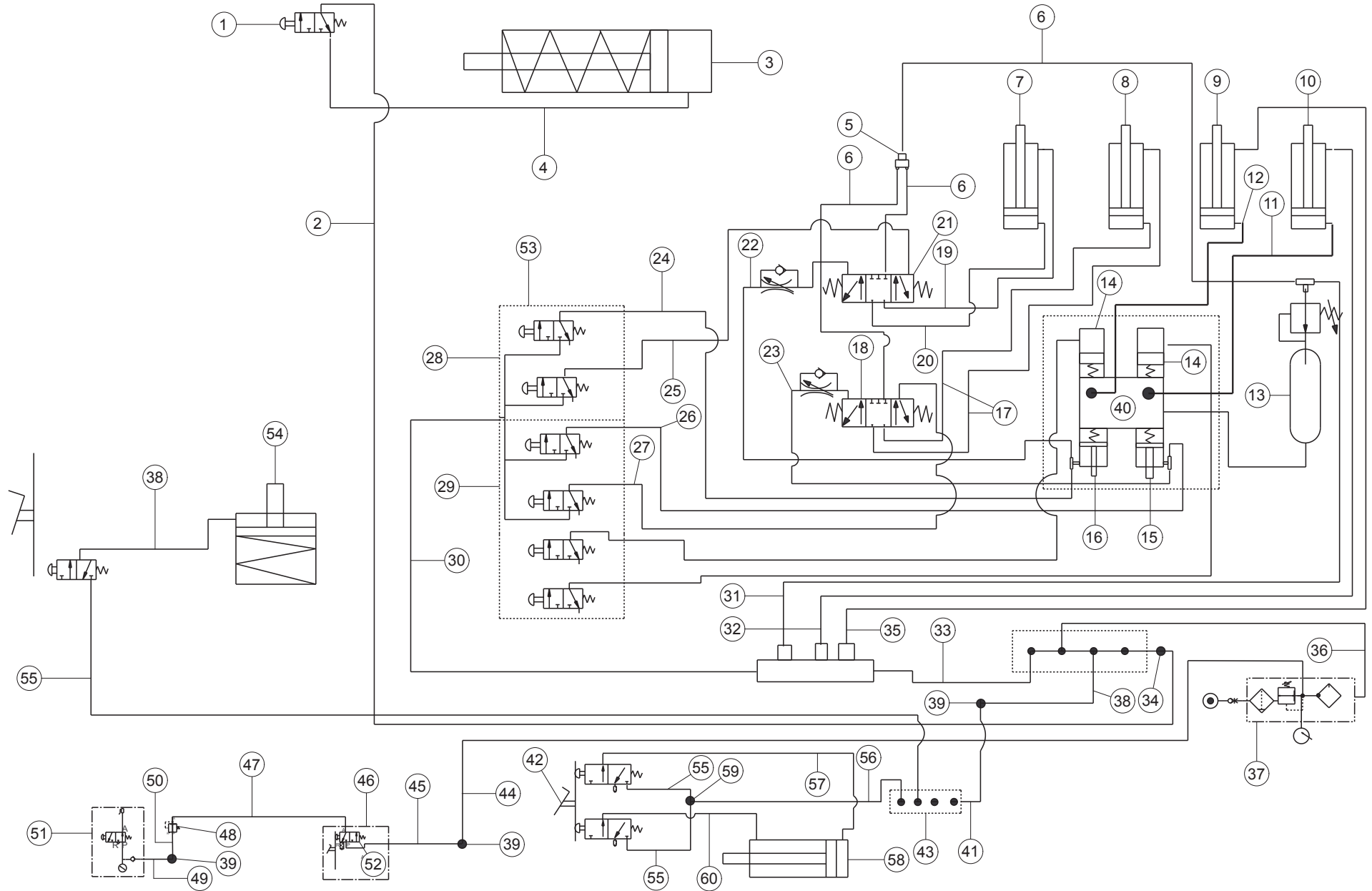



LIST OF COMPONENTS

Drawing N°E - Rev. 0

710205160

PNEUMATIC DIAGRAM
(APPLIES TO ROT.COMBI.201706 - ROT.COMBI.200525
MODELS)

**TYRE-CHANGER SERIES
CLASSIC - COMBI - G1001 - G1065**

No.	Cod.	Description
1	710590800	NA valve
2	317026	4x2.7 black rilsan hose L=2200
3		Guide neck cylinder
4	317026	4x2.7 black rilsan hose L=1300
5		V D4 fitting
6	317026	4x2.7 black rilsan hose L=170
7		Upper bead breaker cylinder Ø40
8		Lower bead breaker cylinder Ø40
9		Upper hydraulic cylinder Ø40
10		Lower hydraulic cylinder Ø40
11	710214630	High pressure hose L=1520
12	B1048000	High pressure hose L=1070
13		Pressure vessel
14		Cylinder D.35
15		Cylinder D.30
16		Upper cylinder D.30
17	317026	4x2.7 black rilsan hose L=2000
18		Lower bead breaker cylinder valve
19	317026	4x2.7 black rilsan hose L=320
20	317026	4x2.7 black rilsan hose L=670
21		Upper bead breaker cylinder valve
22	317026	4x2.7 black rilsan hose L=280
23	BMP90000	4x2.7 yellow rilsan hose L=280
24	317029	4x2.7 white rilsan hose L=1100
25	317028	4x2.7 green rilsan hose L=1000
26	BMP90000	4x2.7 yellow rilsan hose L=1100
27	317027	4x2.7 red rilsan hose L=1000
28		Upper arm control
29		Lower arm control
30	317006	6x4 black rilsan hose L=1000
31	317026	4x2.7 black rilsan hose L=100
32	317026	4x2.7 black rilsan hose L=2130
33	317007	8x6 black rilsan hose L=1150
34	B0171000	6-4 Fixed reduction fitting
35	317026	4x2.7 black rilsan hose L=1700
36	317007	8x6 black rilsan hose L=250
37		Lubricating device
38	317007	8x6 black rilsan hose L=700
39	B0622000	D.8 straight intermediate fitting
40	710291740	Hydraulic Pump assembly
41	317007	8x6 black rilsan hose L=800
42		Ground bead breaker pedalboard
43	B285000	5-way block
44	317009	8x6 blue rilsan hose L=500

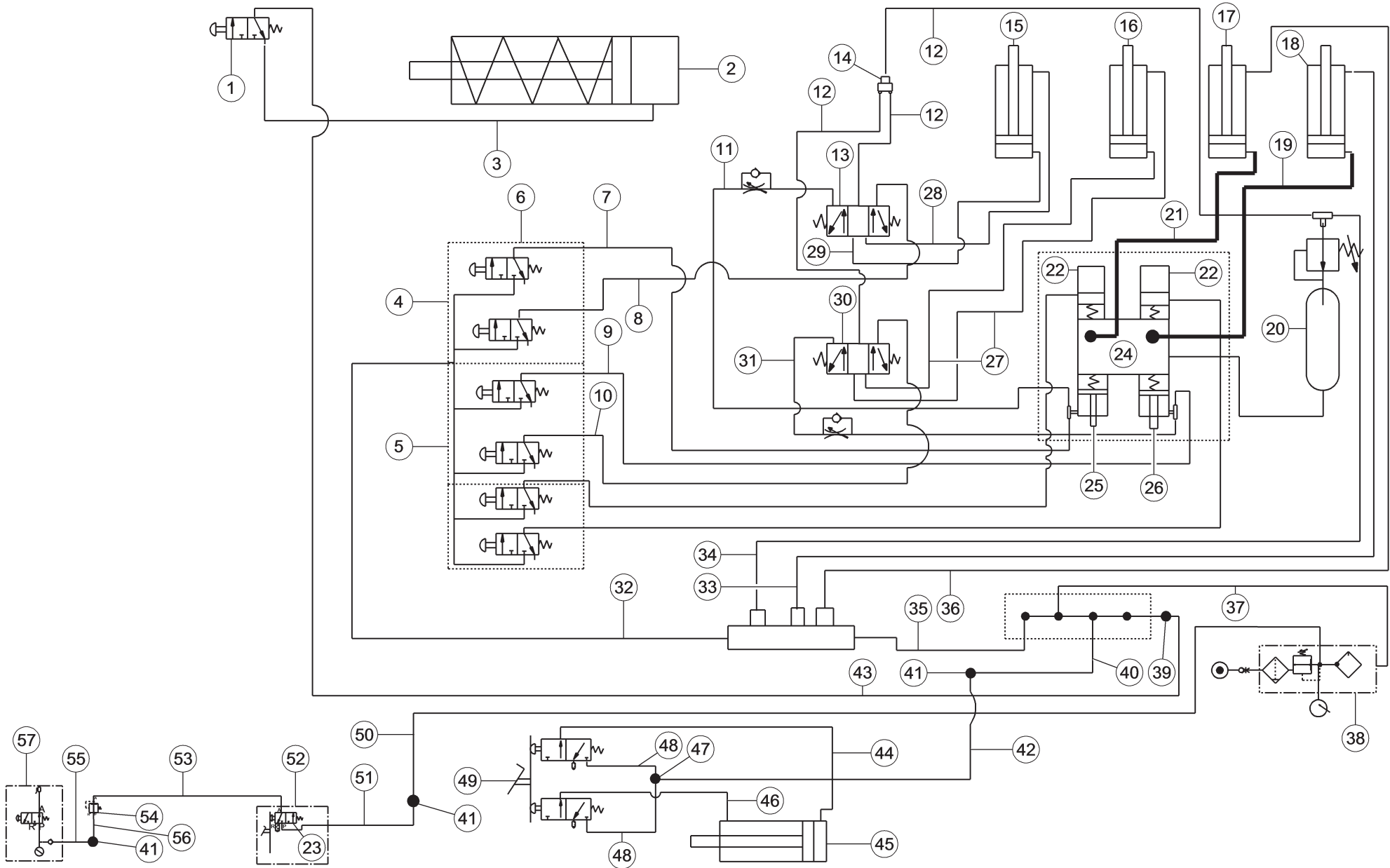

LIST OF COMPONENTS	
Drawing N°F - Rev. 0	710205041

PNEUMATIC DIAGRAM
(APPLIES TO RAV:G1065.200792 MODEL)



LIST OF COMPONENTS

Drawing N°F - Rev. 0

710205041

PNEUMATIC DIAGRAM
(APPLIES TO RAVG1065.200792 MODEL)

**TYRE-CHANGER SERIES
CLASSIC - COMBI - G1001 - G1065**

No.	Cod.	Description
1	710590800	NA valve
2		Guide neck cylinder
3	317026	4x2.7 black rilsan hose L=1300
4		Upper arm control
5		Lower arm control
6		Control valve
7	317029	4x2.7 white rilsan hose L=1100
8	317028	4x2.7 green rilsan hose L=1000
9	BMP90000	4x2.7 yellow rilsan hose L=1100
10	317027	4x2.7 red rilsan hose L=1000
11	317029	4x2.7 white rilsan hose L=280
12	317026	4x2.7 black rilsan hose L=170
13		Upper bead breaker cylinder valve
14		V D4 fitting
15		Upper bead breaker cylinder Ø40
16		Lower bead breaker cylinder Ø40
17		Upper hydraulic cylinder Ø40
18		Lower hydraulic cylinder Ø40
19	710214630	Hydraulic hose
20		Pressure vessel
21	B1048000	Hydraulic hose
22		Cylinder D.35
23		N.O. black
24	710291740	Hydraulic Pump assembly
25		Upper cylinder D.30
26		Lower cylinder D.30
27	317026	4x2.7 black rilsan hose L=2000
28	317026	4x2.7 black rilsan hose L=320
29	317026	4x2.7 black rilsan hose L=670
30		Lower bead breaker cylinder valve
31	BMP90000	4x2.7 yellow rilsan hose L=280
32	317006	6x4 black rilsan hose L=1000
33	317026	4x2.7 black rilsan hose L=2130
34	317026	4x2.7 black rilsan hose L=100
35	317007	8x6 black rilsan hose L=1150
36	317026	4x2.7 black rilsan hose L=1700
37	317007	8x6 black rilsan hose L=250
38		Lubricating device
39	B0171000	6-4 Fixed reduction fitting
40	317007	8x6 black rilsan hose L=700
41	B0622000	D.8 straight intermediate fitting
42	317007	8x6 black rilsan hose L=800
43	317026	4x2.7 black rilsan hose L=2200

Content of the EC declaration of conformity (with reference to point 1.7.4.2, letter c) of directive 2006/42/EC)

With reference to annex II, part 1, section A of directive 2006/42/EC, the declaration of conformity accompanying the machinery contains:

1. the business name and full address of the manufacturer and, where applicable, its authorised representative;
See the first page of the manual
2. name and address of the person authorised to compile the technical file, who must be established in the Community;
It coincides with the manufacturer, see the first page of the manual
3. description and identification of the machine, including generic name, function, model, type, serial number, trade name;
See the first page of the manual
4. a statement explicitly declaring that the machinery is in conformity with all the relevant provisions of this directive and, where appropriate, a similar statement declaring conformity with other community directives and/or relevant provisions with which the machinery complies. These references must be those of the texts published in the Official Journal of the European Union;
The machinery must comply with the following applicable Directives:

2006/42/CE	Machinery Directive
2014/30/EU	Electromagnetic Compatibility Directive
5. where appropriate, the name, address and identification number of the notified body which carried out the EC type-examination referred to in annex IX and the number of the EC type-examination certificate;
N/A
6. where appropriate, the name, address and identification number of the notified body which approved the full quality assurance system referred to in annex X;
N/A
7. where appropriate, reference to the harmonised standards referred to in article 7, paragraph 2, which have been applied;

UNI EN ISO 12100:2010	Safety of machinery - General principles for design - Risk assessment and risk reduction;
CEI EN 60204-1:2018	Safety of machinery - Electrical equipment of machines - Part 1: General requirements
8. where appropriate, reference to other standards and technical specifications applied;

UNI EN 17347:2001	Road vehicles – Machines for mounting and demounting vehicle tyres – Safety requirements
--------------------------	---
9. place and date of declaration;
Ostellato, / /
10. identification and signature of the person authorised to draw up the declaration on behalf of the manufacturer or its authorised representative.
PERETTI PIERLUIGI VP VSG Global Operations

Content of the declaration of conformity (with reference to Schedule 2, Part 1, Annex I, point 1.7.4.2, letter c) of UK Statutory Instrument 2008 No. 1597)

With reference to schedule 2 annex I, part1, section A of UK Statutory Instrument 2008 No. 1597, the declaration of conformity accompanying the machinery contains:

1. the business name and full address of the manufacturer and, where applicable, its authorised representative;
Manufacturer: see the first page of the manual.
 Authorised representative:
VEHICLE SERVICE GROUP UK LTD
3 Fourth Avenue - Bluebridge Industrial Estate - Halstead
Essex CO9 2SY - United Kingdom
2. name and address of the person authorised to compile the technical file;
It coincides with the authorized representative, see point 1
3. description and identification of the machine, including generic name, function, model, type, serial number, trade name;
See the first page of the manual
4. a sentence expressly declaring that the machinery fulfils all the relevant provisions of these Regulations and where appropriate, a similar sentence declaring the conformity with other enactments or relevant provisions with which the machinery complies;
The machinery complies with the following applicable UK Statutory Instruments:
The Supply of Machinery (Safety) Regulations 2008
The Electrical Equipment (Safety) Regulations 2016
The Electromagnetic Compatibility Regulations 2016
5. where appropriate, the name, address and identification number of the approved body which approved the full quality assurance system referred to in Annex X (Part 10 of this Schedule);
N/A
6. where appropriate, the name, address and identification number of the approved body which approved the full quality assurance system referred to in Annex X (Part 10 of this Schedule);
N/A
7. where appropriate, a reference to the designated standards used;

BS EN ISO 12100:2010	Safety of machinery - General principles for design - Risk assessment and risk reduction;
BS EN 60204-1:2018	Safety of machinery - Electrical equipment of machines. General requirements.
BS EN 61000-6-3:2007 +A1:2011 +AC:2012	Electromagnetic compatibility (EMC) - Part 6-3. Generic standards - Emission standard for residential, commercial and light-industrial environments.
BS EN 61000-6-2:2005 +AC:2005	Electromagnetic compatibility (EMC) - Part 6-2. Generic standards - Immunity for industrial environments.
8. where appropriate, reference to other standards and technical specifications applied;
N/A
9. place and date of declaration;
Ostellato, / /
10. identification and signature of the person authorised to draw up the declaration on behalf of the manufacturer or its authorised representative.
PERETTI PIERLUIGI VP VSG Global Operations