

**VSG.2CALL.902276**

**KIT TAMPONI A PANTOGRAFO  
FLIP-UP PADS KIT**

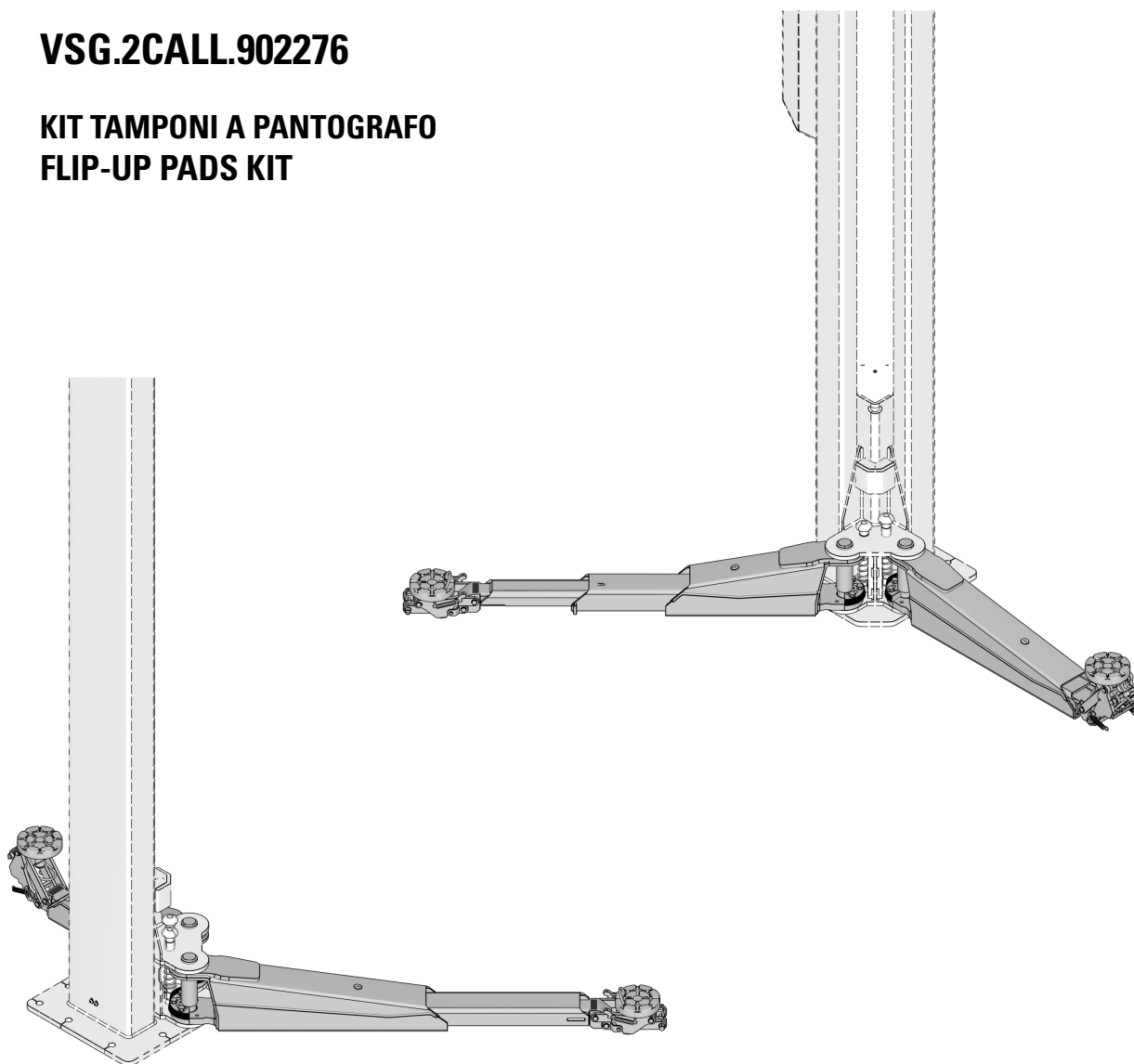

Manuale valido per i seguenti modelli

This manual is valid for the following models

<b>ROT.SP32X.198549X0</b>
<b>RAV.KPX32.198785X0</b>
<b>RAV.KPE32.198662X0</b>
<b>SPA.SDX32.199041X0</b>
<b>RAV.KPE32.198662X1</b>
<b>RAV.KPE32.198747X1</b>
<b>RAV.KPC32.198709X1</b>
<b>ROT.SP32C.199225X1</b>
<b>ROT.SP32E.198273X1</b>
<b>SPA.SDC32.199119X1</b>

<b>SPA.SDE32.199188X1</b>
<b>RAV.KPX32.198792X0</b>
<b>ROT.SP32E.198280X0</b>
<b>RAV.KPS32.198686X1</b>
<b>ROT.SP32S.199324X1</b>
<b>SPA.SDS32.198921X1</b>
<b>RAV.KPX32.198570X0</b>
<b>RAV.KPX32.198624X0</b>
<b>ROT.SP32X.198723X0</b>



## ATTENZIONE!

- Il presente manuale costituisce parte integrante del prodotto, dovrà seguire tutta la vita operativa del sollevatore.
- Conservarlo, quindi, in luogo noto e a portata di mano per poterlo consultare ogni qualvolta sorgano dubbi.
- L'utilizzo del sollevatore è consentito esclusivamente a personale adeguatamente istruito che abbia letto e compreso il presente manuale.
- Ogni danno derivante dalla mancata osservanza delle indicazioni contenute nel presente manuale e da un uso improprio del sollevatore esime la Ravaglioli da ogni responsabilità.

## CAUTION!

- This manual is an integral part of the product and must be kept together with the lift throughout its lifetime.
- Therefore, store it in a known and readily available place so as to refer to it any time doubts arise.
- Only suitably trained personnel who have read and understood this manual may use the lift.
- Any damage resulting from improper use of the lift and failure to follow the instructions contained in this manual will release RAVAGLIOLI from any liability.

<b>COMPOSIZIONE DEL MANUALE</b> 6 pagine (comprese le copertine)	<b>COMPOSITION OF MANUAL</b> 6 pages (including cover pages)	<b>ZUSAMMENSETZUNG DER ANLEITUNG</b> 6 Seiten (inkl. Deckblätter)	<b>COMPOSITION DE LA NOTICE</b> 6 pages (pages de la couverture incluses)	<b>COMPOSICIÓN DEL MANUALE</b> 6 páginas (incluidas las cubiertas)
--	--	---	---	--

## INDICE

CAP. 1	SIMBOLOGIA UTILIZZATA NEL MANUALE .....	IT_2
CAP. 2	PRESENTAZIONE.....	IT_3
2.1	DESCRIZIONE DELL'ACCESSORIO .....	IT_3
2.2	DESTINAZIONE D'USO .....	IT_3
CAP. 3	MONTAGGIO ACCESSORIO .....	IT_4

















## INDEX

CH. 1	SYMBOLS USED IN THE MANUAL.....	IT_2
CH. 2	INTRODUCTION.....	IT_3
2.1	DESCRIPTION OF THE ACCESSORY.....	IT_3
2.2	INTENDED USE.....	IT_3
CH. 3	ACCESSORY ASSEMBLY .....	IT_4

**CAP. 1 SIMBOLOGIA UTILIZZATA NEL MANUALE**

**CH. 1 SYMBOLS USED IN THE MANUAL**

	Attenzione!
	Pericolo elettricità
	Pericolo carichi sospesi
	Pericolo carrelli elevatori ed altri veicoli industriali
	Pericolo organi in movimento
	Pericolo schiacciamento mani
	Sollevamento dall'alto
	Vietato
	Obbligatorio consultare il manuale/libretto di istruzioni
	Personale specializzato
	Obbligo
	Vietato passare e sostare sotto i carichi sospesi
	Usare scarpe protettive
	Usare i guanti
	Usare indumenti protettivi
	Usare gli occhiali
	Obbligatorio disconnettere prima di effettuare manutenzioni o riparazioni

	Caution!
	Electrical hazard
	Danger of suspended loads
	Danger fork-lift trucks and other industrial vehicles
	Danger of moving parts
	Danger of crushing hands
	Lifting from above
	Prohibited
	It is mandatory to consult the manual/ instruction booklet
	Specialist staff
	Obligation
	Passing and standing under suspended loads is prohibited
	Use protective shoes
	Use gloves
	Wear protective clothing
	Use goggles
	It must be disconnected before maintenance or repairs

**CAP. 2 PRESENTAZIONE**

**2.1 DESCRIZIONE DELL'ACCESSORIO**

• Nome prodotto: KIT TAMPONI A PANTOGRAFO

**2.2 DESTINAZIONE D'USO**

L'accessorio è destinato ai sollevatori con portata a 3200kg.



**Attenzione**  
Si informano gli utenti che l'installazione del tampone a pantografo, comporta una riduzione della portata massima complessiva del sollevatore pari a 3080Kg, causata da un limite massimo sul singolo pantografo di 900 kg.

**CH. 2 INTRODUCTION**

**2.1 DESCRIPTION OF THE ACCESSORY**

• Product name: FLIP-UP PADS KIT

**2.2 INTENDED USE**

The accessory is intended for lifts with a load capacity of 3200 kg.



**Warning**  
We inform the users that the installation of the pantograph pad will result in a reduction of the overall maximum lift capacity of 3080 kg, caused by a maximum limit on the individual pantograph of 900 kg.

- 1 BRACCI LUNGI
- 2 BRACCI CORTI
- 3 TARGHETTA PORTATA 900KG
- 4 TARGHETTA RIPARTIZIONE CARICO 3080kg

- 1 LONG ARMS
- 2 SHORT ARMS
- 3 CAPACITY PLATE 900 KG
- 4 LOAD DISTRIBUTION PLATE 3080kg

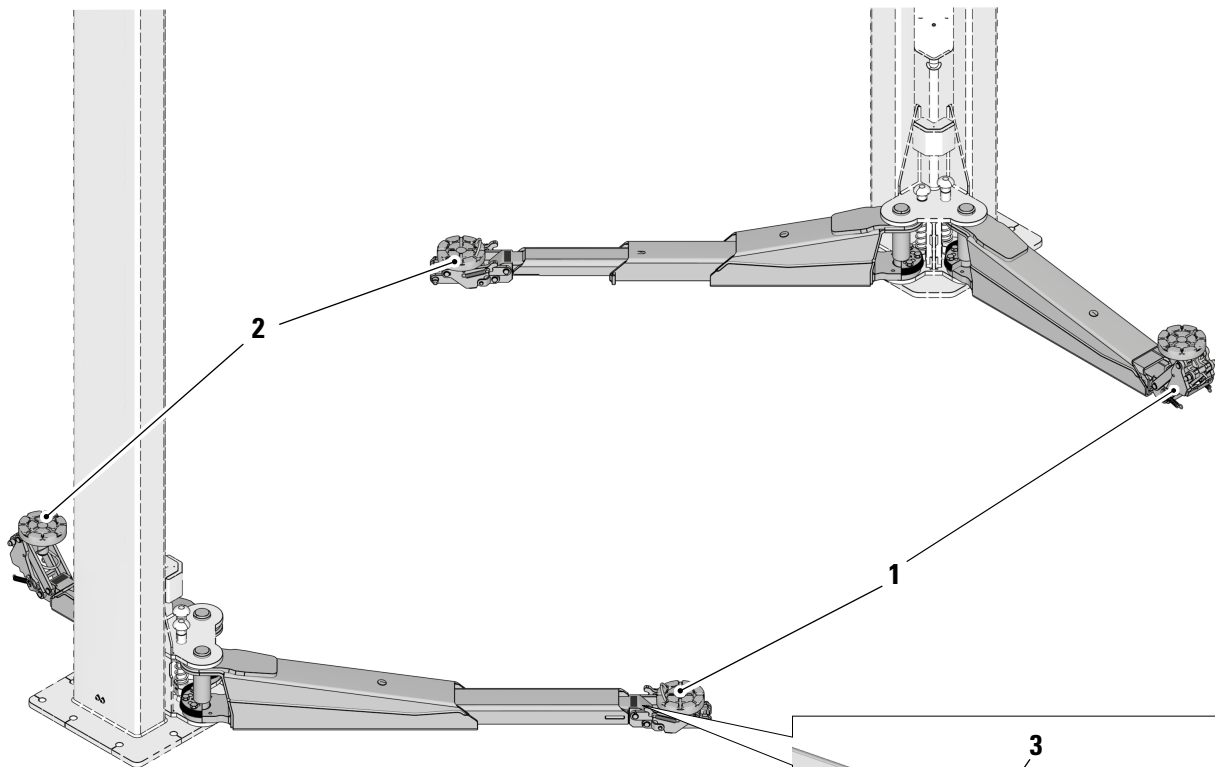

**RIPARTIZIONE CARICO**  
**LOAD DISTRIBUTION**  
**GEWICHT VERTEILUNG**  
**REPARTITION DE CHARGE**  
**REPARTICION DE LA CARGA**

C	P1	P2	Q=P1+P2
mm	kg	kg	kg
1000	1230	1850	3080

**4**



### CAP. 3 MONTAGGIO ACCESSORIO

- Portare i carrelli ad una altezza di 70-80 cm.
- Svitare il tappo (1);
- Muovere lo sfilo (2) fino a che la vite (3) sia in linea con il foro del tappo;
- Svitare la vite (3) e rondella;
- Sfilare lo sfilo (2) dal corpo braccio principale e montare l'accessorio (4) (completo di sfilo e tampone).
- Fissare la vite (3) e rondella sull'accessorio (4) e rimettere il tappo (1).

#### PRECAUZIONI D'USO

- Porre particolarmente attenzione al posizionamento dei tamponi sotto al veicolo da sollevare e verificarne con cura la stabilità prima di procedere alla manovra di sollevamento.
- Nel meccanismo sottostante il tampone non deve essere presente terra, fango o qualunque materiale possa impedire il libero movimento.
- Verificare periodicamente che le camme di appoggio si inseriscano correttamente nella sede senza esitazioni o impuntamenti e che le molle di richiamo non siano danneggiate.

### CH. 3 ACCESSORY ASSEMBLY

- Bring the carriages to a height of 70-80 cm.
- Unscrew the cap (1);
- Move the pullout (2) until the screw (3) is in line with the hole in the cap;
- Loosen the screw (3) and washer;
- Remove the pullout (2) from the main arm housing and fit the accessory (4) (complete with pullout and pad).
- Fasten the screw (3) and washer on the accessory (4) and refit the cap (1).

#### IMPORTANT CHECKS TO BE MADE

- Pay special attention when positioning the pads under the vehicle to be lifted and thoroughly check its stability before starting the lifting procedure.
- In the mechanism underneath the pad there must not be soil, mud or any other material hindering free movements.
- Check at regular intervals that the rest cams are correctly inserted into their seat without counteraction or sticking and that the retracting springs are not damaged.

