



7503-M006-00

**TYRE-CHANGER SERIES
NAV26HW - GRS926 - GGRS926**

INSTRUCTION MANUAL
Applicable to the following models
ROT.N26HW.201874
RAV.GR926.206336
RAV.GR926.200518
SPA.GR926.205957

EN

ORIGINAL INSTRUCTIONS

For spare parts drawings refer to the document "LIST OF COMPONENTS" to be requested from the manufacturer.

- For any further information please contact your local dealer or call:

VEHICLE SERVICE GROUP ITALY S.r.l

Via Filippo Brunelleschi, 9 - 44020 Ostellato - Ferrara - Italy
Phone (+39) 051 6781511 - Fax (+39) 051 846349 - e-mail: aftersales.emea@vsgdover.com

7503-M006-00 - Rev. n. 00 (04/2024)

SUMMARY

GENERAL DESCRIPTION _____	3	12.0 USE OF THE EQUIPMENT _____	16
SYMBOLS USED IN THE MANUAL _____	4	12.1 <i>Precaution measures during tyre</i>	
PLATES LOCATION DRAWING _____	5	<i>removal and fitting</i> _____	16
1.0 GENERAL INTRODUCTION _____	7	12.2 <i>Preliminary operations</i> _____	18
1.1 <i>Introduction</i> _____	7	12.3 <i>Preparing the wheel</i> _____	18
2.0 INTENDED USE _____	7	12.4 <i>Wheel clamping</i> _____	18
2.1 <i>Training of personnel</i> _____	7	12.5 <i>Functioning of roller holder arm</i> _____	20
3.0 SAFETY DEVICES _____	8	12.6 <i>Tubeless tyres</i> _____	21
3.1 <i>Residual risks</i> _____	8	12.6.1 <i>Bead breaking</i> _____	21
4.0 IMPORTANT SAFETY INSTRUCTIONS _	9	12.6.2 <i>Demounting</i> _____	23
4.1 <i>General safety rules</i> _____	9	12.6.3 <i>Mounting</i> _____	25
5.0 PACKING AND MOBILIZATION FOR		12.7 <i>Tyres with inner tube</i> _____	27
TRANSPORT _____	10	12.7.1 <i>Bead breaking</i> _____	27
6.0 UNPACKING _____	11	12.7.2 <i>Demounting</i> _____	27
7.0 MOBILIZATION _____	11	12.7.3 <i>Mounting</i> _____	29
8.0 WORKING ENVIRONMENT		13.0 ROUTINE MAINTENANCE _____	31
CONDITIONS _____	12	14.0 TROUBLESHOOTING TABLE _____	33
8.1 <i>Work position</i> _____	12	15.0 TECHNICAL DATA _____	35
8.2 <i>Working area</i> _____	12	15.1 <i>Technical electrical data</i> _____	35
8.3 <i>Lighting</i> _____	12	15.2 <i>Technical mechanical data</i> _____	35
9.0 ASSEMBLY AND PREPARATION		15.3 <i>Dimensions</i> _____	36
FOR USE _____	13	16.0 STORING _____	37
9.1 <i>Anchoring system</i> _____	13	17.0 SCRAPPING _____	37
10.0 ELECTRICAL CONNECTIONS _____	14	18.0 REGISTRATION PLATE DATA _____	37
10.1 <i>Oil check on oil-pressure power unit</i> _	15	19.0 FUNCTIONAL DIAGRAMS _____	37
10.2 <i>Check of motor rotation direction</i> _____	15	<i>Drawing A - Wiring diagram</i> _____	38
10.3 <i>Electrical checks</i> _____	15	<i>Drawing B - Hydraulic diagram</i> _____	39
11.0 CONTROLS _____	16	CONTENT OF THE EC DECLARATION	
11.1 <i>Control device</i> _____	16	OF CONFORMITY _____	41
		CONTENT OF THE UK DECLARATION	
		OF CONFORMITY _____	42

GENERAL DESCRIPTION



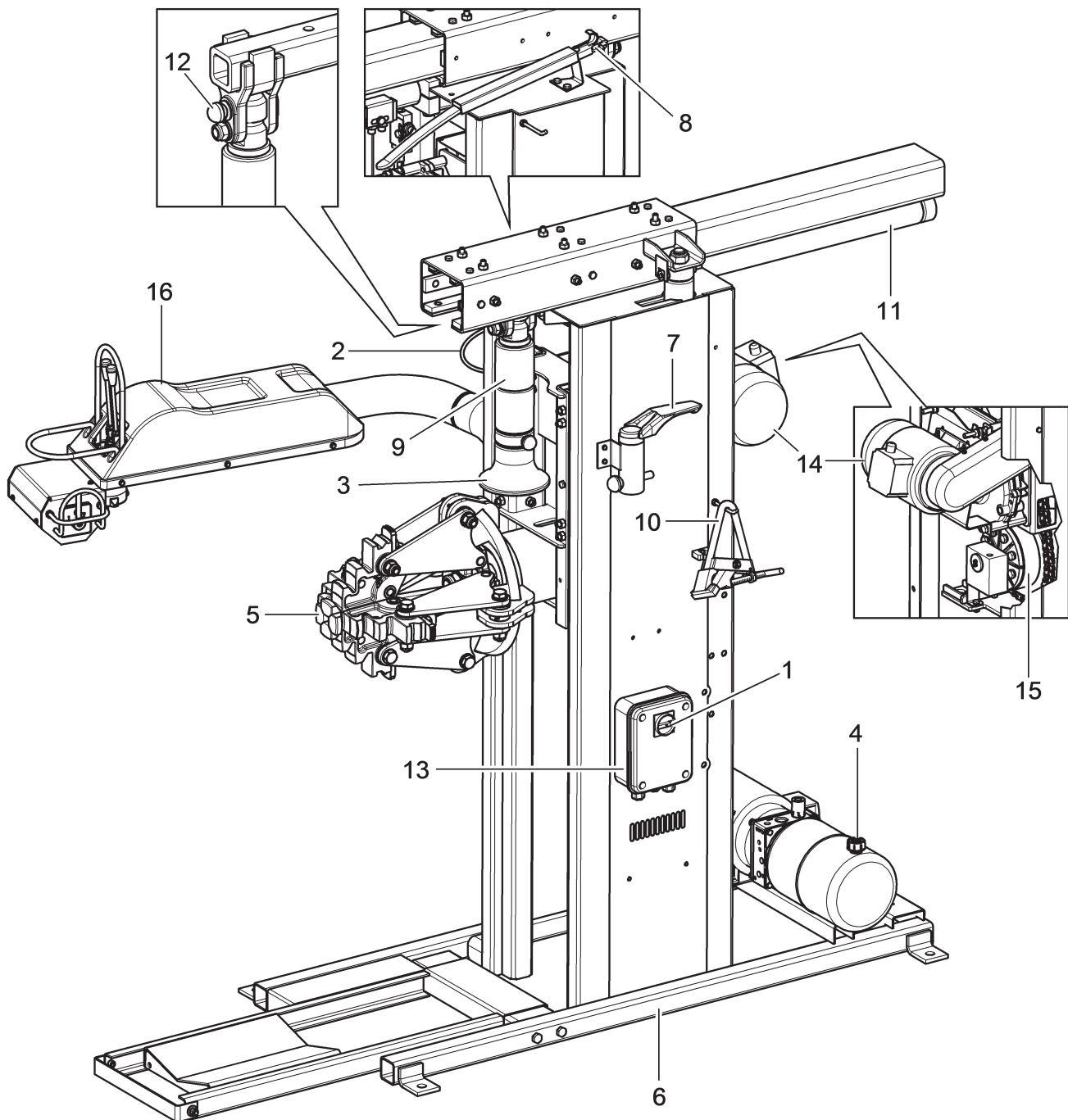



Fig. 1









KEY

- | | |
|------------------------------------|---|
| 1 - Main switch | 10 - Clamp for alloy rims (optional) |
| 2 - Grease-holder ring | 11 - Bead breaker tool/roller movement cylinder |
| 3 - Bead breaker roller | 12 - Tool holder arm locking pin |
| 4 - Oil-pressure power unit | 13 - Electric cabinet |
| 5 - Self-centring chuck | 14 - Chuck rotation motor |
| 6 - Frame | 15 - Self-centring chuck opening/closing cylinder |
| 7 - Bead breaker hook tool | 16 - Control unit |
| 8 - Bead lever | |
| 9 - Bead breaker roller holder arm | |

SYMBOLS USED IN THE MANUAL

Symbols	Description
	Read instruction manual.
	Wear work gloves.
	Wear work shoes.
	Wear safety goggles.
	Mandatory. Operations or jobs to be performed compulsorily.
	Warning. Be particularly careful (possible material damages).
	Danger! Be particularly careful.

Symbols	Description
	Note. Indication and/or useful information.
	Move with fork lift truck or pallet truck.
	Lift from above.
	Technical assistance necessary. Do not perform any interventions.
	Caution: hanging loads.
	Danger: tyre could fall.
	Hand crushing danger.

PLATES LOCATION DRAWING

Fig. 2

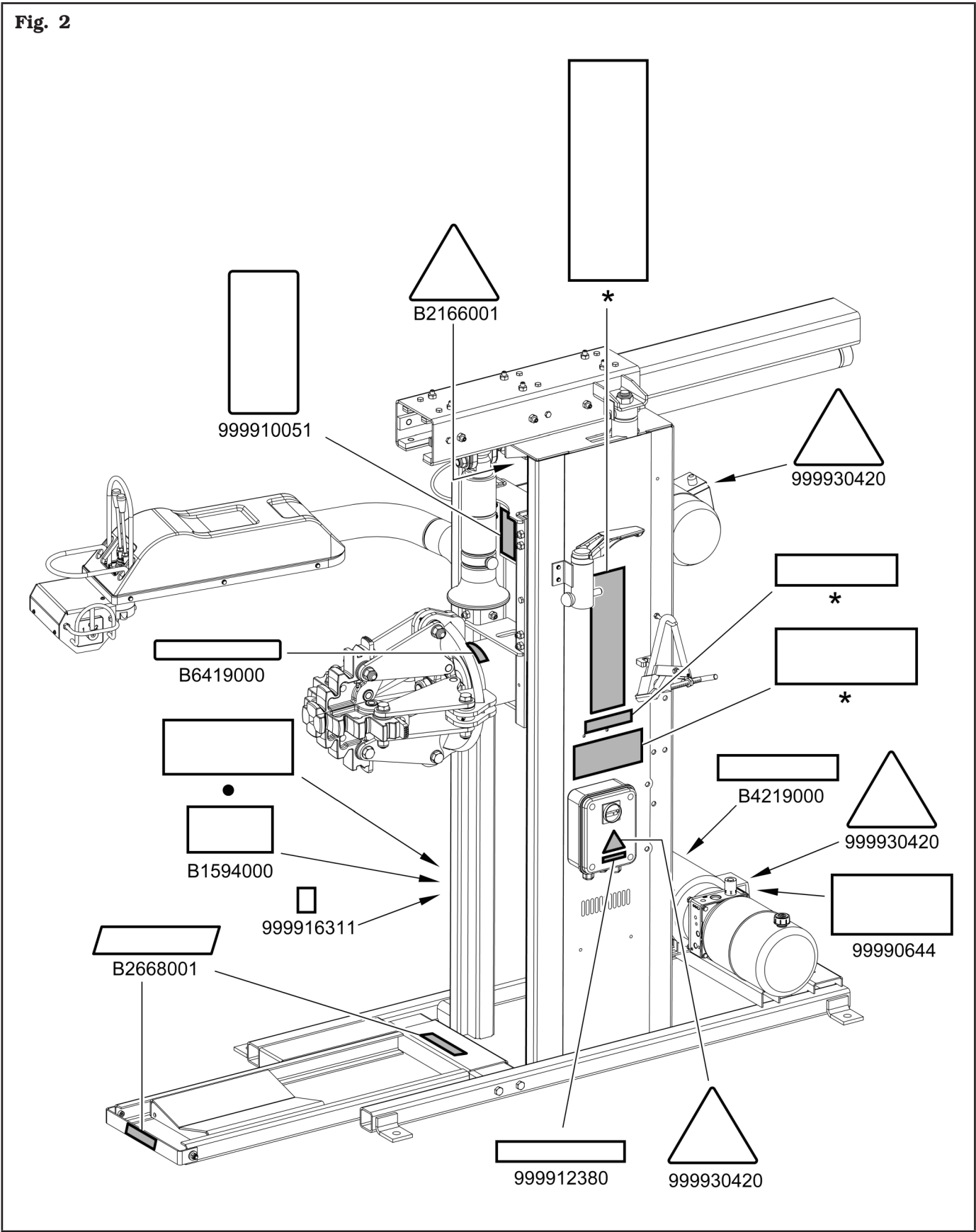

Code numbers of nameplates

B1594000	<i>Date indicating nameplate</i>
B2166001	<i>Bead breaker danger nameplate</i>
B2668001	<i>Wheel lifting device danger nameplate</i>
B4182000	<i>Electric motor specifications nameplate (applied to the supply cable)</i>
B4219000	<i>Rotation indicating nameplate</i>
B6419000	<i>Rotation nameplate</i>
99990644	<i>Chuck rotation index nameplate</i>
999910051	<i>Protection device use nameplate</i>
999912380	<i>400 V - 3 Ph - 50 Hz voltage nameplate</i>
999916311	<i>Rubbish skip nameplate</i>
999930420	<i>Electric shock danger nameplate</i>
●	<i>Serial number nameplate</i>
*	<i>Manufacturer nameplate or machine name</i>



IF ONE OR MORE NAMEPLATES ARE MISSING FROM THE EQUIPMENT OR BECOMES DIFFICULT TO READ. REPLACE IT AND QUOTE ITS/THEIR PART NUMBER/S WHEN REORDERING.



SOME OF THE PICTURES IN THIS MANUAL HAVE BEEN OBTAINED FROM PICTURES OF PROTOTYPES, THEREFORE THE STANDARD PRODUCTION EQUIPMENT AND ACCESSORIES CAN BE DIFFERENT THAN PICTURED.

1.0 GENERAL INTRODUCTION

This manual is an integral part of the equipment and must be retained for the whole operating life of the equipment itself.

Carefully study this manual. It contains important instructions regarding **FUNCTIONING, SAFE USE and MAINTENANCE.**



KEEP THE MANUAL IN A KNOWN EASILY ACCESSIBLE PLACE FOR ALL SERVICE TECHNICIAN TO CONSULT IT WHENEVER IN DOUBT.



THE MANUFACTURER CAN NOT BE HELD RESPONSIBLE FOR ANY DAMAGE TO THE SHOP, EQUIPMENT OR CUSTOMER WHEEL/TYRE THAT MAY OCCUR WHEN THE INSTRUCTIONS GIVEN IN THIS MANUAL ARE NOT FOLLOWED. DISREGARDING THESE INSTRUCTIONS MAY CAUSE INJURY OR DEATH.

1.1 Introduction

Thanks for purchasing this tyre changer! The tyre changer is designed and built for professional garages. The tyre changer is easy to use with safety in mind. Following the care and maintenance outlined in this tyre changer manual your tyre changer will provide years of service.

2.0 INTENDED USE

The equipment described in this manual is a tyre changer that uses two systems:

- an electric motor coupled to a gearbox to handle the tyre rotation, and
- a hydraulic pump system to manage the locking and movement of the hydraulic cylinders with multiple assembly/disassembly tools.

The equipment is to be used only for the mounting and demounting of any type of wheel with the whole rim (drop centre and with bead) with diameters and width values mentioned in "Technical specifications" chapter.

The equipment is NOT intended to be used for tyre inflation.



THIS EQUIPMENT MUST ONLY BE USED FOR THE PURPOSE FOR WHICH IT IS SPECIFICALLY DESIGNED. ANY OTHER USES ARE TO BE CONSIDERED IMPROPER AND THEREFORE UNACCEPTABLE.



THE MANUFACTURER CANNOT BE HELD RESPONSIBLE FOR ANY DAMAGES CAUSED BY IMPROPER, ERRONEOUS, OR UNACCEPTABLE USE.

2.1 Training of personnel

The machine may be operated only by suitably trained and authorized personnel.

Given the complexity of the operations necessary to manage the equipment and carry out the operations safely and efficiently, the personnel must be trained in such a way that they learn all the information necessary to operate the machine as intended by the manufacturer.



CAREFULLY READING THIS INSTRUCTION MANUAL AND A SHORT PERIOD OF TRAINING BY SKILLED PERSONNEL REPRESENT A SATISFACTORY FORM OF TRAINING.

3.0 SAFETY DEVICES



DAILY CHECK THE INTEGRITY AND THE FUNCTIONALITY OF THE SAFETY AND PROTECTION DEVICES ON THE EQUIPMENT.

The product is equipped with:

- **hold-to-run controls** (immediate stop of operation when the control is released).
- **Control logic disposition**
To prevent the operator from making dangerous mistakes.



NO MODIFICATION OR CALIBRATION OF THE OPERATING PRESSURE OF THE MAXIMUM PRESSURE VALVE OR OF THE HYDRAULIC CIRCUIT PRESSURE LIMITER IS PERMITTED.

- **Controlled check valves** on:
 - opening of self-centring chuck jaws,
 - lifting of self-centring chuck,
 - tool roller movement.

These valves will stop unintended movement of the jaws, of wheel clamping self-centring chuck and of the tool roller.

- **Fuses** on the electric supply line of self-centring chuck motor:

• **Fixed protections and guards**

This equipment has permanent guards installed to avoid potential risks of getting crushed, cut or squeezed.

These protections can be identified in **Fig. 3**.

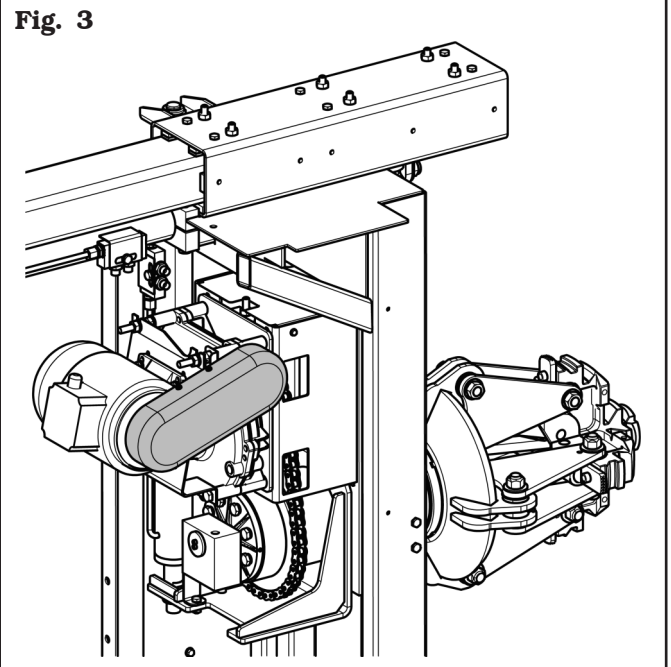

Fig. 3

3.1 Residual risks

The equipment was subjected to a complete analysis of risks according to reference standard EN ISO 12100. Risks are as reduced as possible in relation with technology and equipment functionality.

Any residual risks have been highlighted in this manual through pictograms and adhesive warning signals placed on the equipment: their location is represented in "PLATE LOCATION DRAWING" (see **Fig. 2**).

4.0 IMPORTANT SAFETY INSTRUCTIONS

When using your garage equipment, basic safety precautions should always be followed, including the following:

1. Read all instructions.
2. Care must be taken as burns can occur from touching hot parts.
3. Do not operate equipment with a damaged cord or if the equipment has been dropped or damaged – until it has been examined by a qualified service person.
4. Do not let a cord hang over the edge of the table, bench, or counter or come in contact with hot manifolds or moving fan blades.
5. If an extension cord is necessary, a cord with a current rating equal to or more than that of the equipment should be used. Cords rated for less current than the equipment may overheat. Care should be taken to arrange the cord so that it will not be tripped over or pulled.
6. Always unplug equipment from electrical outlet when not in use. Never use the cord to pull the plug from the outlet. Grasp plug and pull to disconnect.
7. Let equipment cool completely before putting away. Loop cord loosely around equipment when storing.
8. To reduce the risk of fire, do not operate equipment in the vicinity of open containers of flammable liquids (gasoline).
9. Adequate ventilation should be provided when working on operating internal combustion engines.
10. Keep hair, loose clothing, fingers, and all parts of body away from moving parts.
11. To reduce the risk of electric shock, do not use on wet surfaces or expose to rain.
12. Use only as described in this manual. Use only manufacturer's recommended attachments.
13. ALWAYS WEAR SAFETY GLASSES. Everyday eyeglasses only have impact resistant lenses, they are not safety glasses.

SAVE THESE INSTRUCTIONS

4.1 General safety rules



- Any tampering with or modification to the machine not previously authorized by the manufacturer exempts the latter from all responsibility for damage caused by or derived from said actions.
- Removing of or tampering with the safety devices or with the warning signals placed on the equipment leads to serious dangers and represents a transgression of European safety standards.
- The equipment may be used only in areas free from the danger of explosion or fire.
- The use of only original accessories and spare parts is advised. Our equipment is designed to function only with original accessories.
- The installation must be performed by qualified personnel in full compliance with the instructions given below.
- Ensure that there are no dangerous situations during the machine operating manoeuvres. Immediately stop the equipment if it malfunctions and contact the customer service of the authorized dealer.
- In emergency situations and before carrying out any maintenance or repairs, isolate the equipment from energy sources by disconnecting the electrical and/or pneumatic power supply using the main switch.
- Ensure that the area around the equipment is free of potentially dangerous objects and that the area is oil free since this could damage the tyre. Oil on the floor is also a slipping hazard for the operator.



THE MANUFACTURER DENIES ANY RESPONSIBILITY IN CASE OF DAMAGES CAUSED BY UNAUTHORIZED MODIFICATIONS OR BY THE USE OF NON ORIGINAL COMPONENTS OR EQUIPMENT.



OPERATORS MUST WEAR SUITABLE WORK CLOTHES, PROTECTIVE GLASSES AND GLOVES, AGAINST THE DANGER FROM THE SPRAYING OF DANGEROUS DUST, AND POSSIBLY LOWER BACK SUPPORTS FOR THE LIFTING OF HEAVY PARTS. DANGLING OBJECTS LIKE BRACELETS MUST NOT BE WORN, AND LONG HAIR MUST BE TIED UP. FOOTWEAR SHOULD BE ADEQUATE FOR THE TYPE OF OPERATIONS TO BE CARRIED OUT.



- The equipment handles and operating grips must be kept clean and free from oil.
- The workshop must be kept clean and dry and not in an out doors location. Make sure that the working premises are properly lit.
The equipment can be operated by a single operator at a time. Unauthorized personnel must remain outside the working area, as shown in **Fig. 6**. Avoid any hazardous situations. Do not use this equipment when the shop is damp or the floor slippery and do not use this equipment out doors.
- When operating and servicing this equipment, carefully follow all in force safety and accident-prevention precautions.
The equipment must not be operated by untrained personnel.



THE EQUIPMENT OPERATES WITH PRESSURIZED HYDRAULIC FLUID. MAKE SURE EVERY COMPONENT OF THE HYDRAULIC CIRCUIT IS ALWAYS PROPERLY LOCKED, ANY PRESSURIZED LEAKS MAY CAUSE SERIOUS INJURIES OR WOUNDS.



ALWAYS KEEP THE HYDRAULIC CONTROLS IN THE NEUTRAL POSITION.

5.0 PACKING AND MOBILIZATION FOR TRANSPORT





HAVE THE EQUIPMENT HANDLED BY SKILLED PERSONNEL ONLY. THE LIFTING EQUIPMENT MUST WITHSTAND A MINIMUM RATED LOAD EQUAL TO THE WEIGHT OF THE PACKED EQUIPMENT (SEE PARAGRAPH "TECHNICAL SPECIFICATIONS").

The equipment is supplied completely assembled, packed in a cardboard box. Movement must be by pallet-lift or fork-lift trolley. The fork lifting points are indicated on the packing, (see **Fig. 4**).

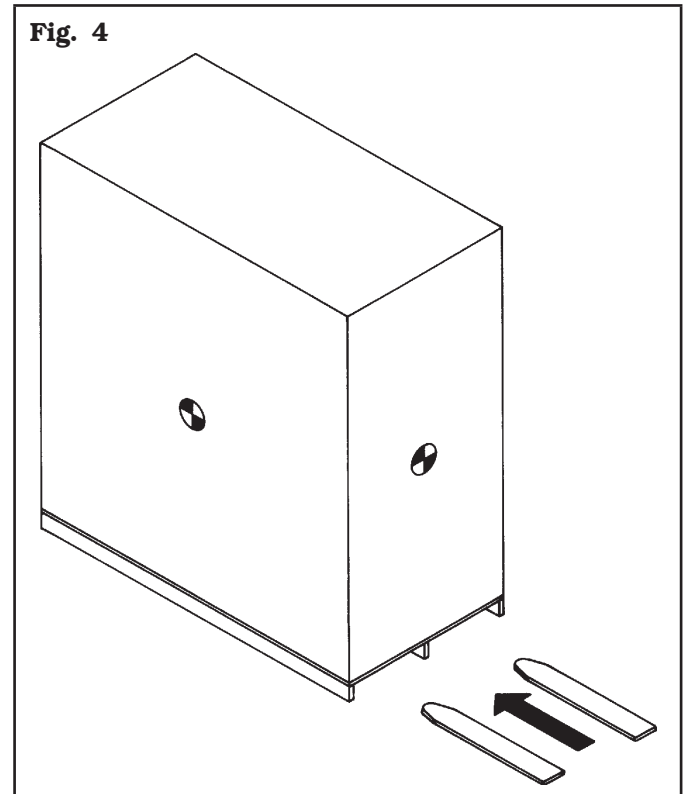
Fig. 4



6.0 UNPACKING

DURING UNPACKING, ALWAYS WEAR GLOVES TO PREVENT ANY INJURY CAUSED BY CONTACT WITH PACKAGING MATERIAL (NAILS, ETC.).

The cardboard box is supported with plastic strapping. Cut the strapping with suitable scissors. Use a small knife to cut along the lateral axis of the box and open it like a fan.

It is also possible to unmail the cardboard box from the pallet it is fixed to. After removing the packing, and in the case of the equipment packed fully assembled, check that the machine is complete and that there is no visible damage.

If in doubt **do not use the equipment** and refer to professionally qualified personnel (to the seller).

The packing (plastic bags, expanded polystyrene, nails, bolts, timber, etc.) should not be left within reach of children since it is potentially dangerous. These materials should be deposited in the relevant collection points if they are pollutants or non biodegradable.



THE BOX CONTAINING THE ACCESSORIES IS CONTAINED IN THE WRAPPING. DO NOT THROW IT AWAY WITH THE PACKING.

7.0 MOBILIZATION



THE LIFTING EQUIPMENT MUST WITHSTAND A MINIMUM RATED LOAD EQUAL TO THE WEIGHT OF THE EQUIPMENT (SEE PARAGRAPH TECHNICAL SPECIFICATIONS). NON FAR ALLOW THE LIFTED EQUIPMENT TO SWING.

If the equipment has to be moved from its normal work post the transport must be conducted by following the instructions listed below:

- protect the exposed corners with suitable material (bubble wrap/cardboard);
- do not use metallic cables for lifting;
- make sure that the equipment power supply is not connected;
- lift and transport with suitable device as indicated in **Fig. 5** (forks introduced in the middle to ensure a correct loads distribution).

Fig. 5

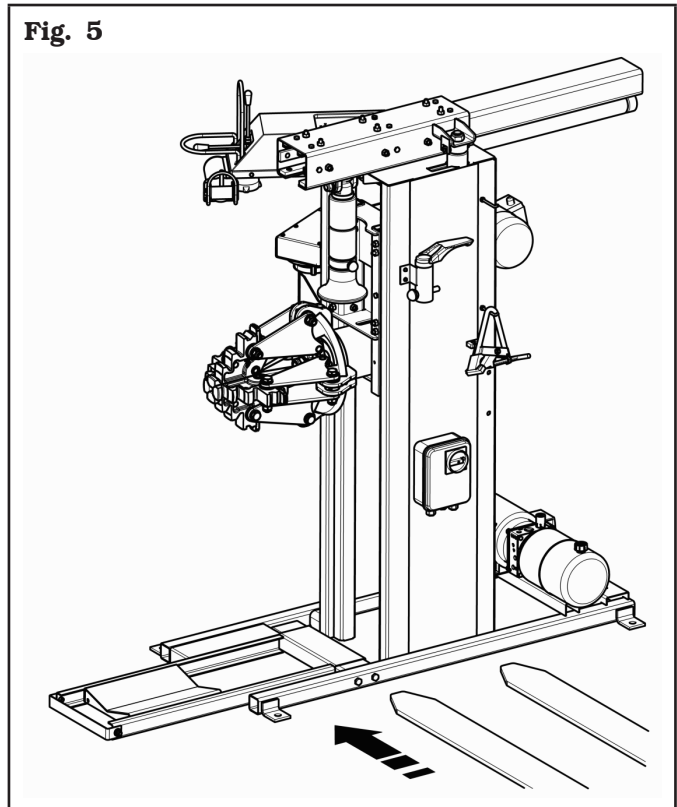

8.0 WORKING ENVIRONMENT CONDITIONS

The equipment must be operated under proper conditions as follows:

- temperature: +5 °C - +40 °C (+41 °F - +104 °F);
- relative humidity: 30 - 95% (dew-free);
- atmospheric pressure: 860 - 1060 hPa (mbar) (12.5 - 15.4 psi).

The use of the equipment in ambient conditions other than those specified above is only allowed after prior agreement with and approval of the manufacturer.

8.1 Work position

In **Fig. 6** it's possible to define work positions **A**, **B**, **C** which will be referred to in the description of equipment operative phases.

Positions **A** and **B** must be considered as the main positions for tyre mounting and demounting and for wheel clamping on self-centring chuck, while positions **A** and **C** are the best positions to follow tyre bead breaking and demounting operations.

Working in these positions allows better precision and speed during operating phases as well as greater safety for the operator.

8.2 Working area

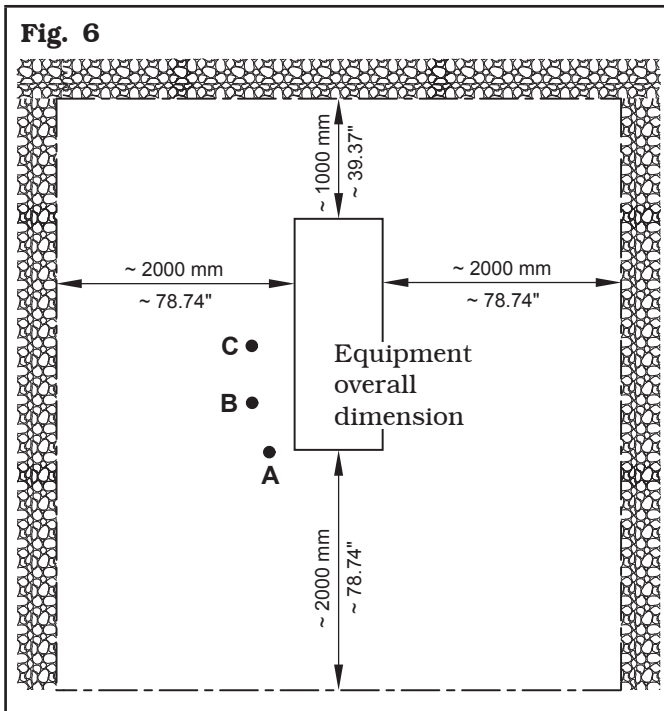

The location of the equipment requires a usable space as indicated in **Fig. 6**. The positioning of the equipment must be executed according to the distances shown. From the control position the operator is able to observe all the equipment and surrounding area.

Operator must prevent unauthorized personnel or objects that could be dangerous from entering the area. The equipment must be secured to a flat floor surface, preferably of cement or tiled. Avoid yielding or irregular surfaces.

The equipment base floor must be able to support the loads transmitted during operation. This surface must have a capacity load of at least 500 kg/m² (100 lb/ft²). The depth of the solid floor must guarantee the tightness of the anchor plugs.

8.3 Lighting

The equipment must be placed in a sufficiently lit environment in compliance with current regulations.

9.0 ASSEMBLY AND PREPARATION FOR USE



After having freed the components from the packing check that they are complete, and that there are no anomalies, then comply with the following instructions for the assembly of the components making use of the attached series of illustrations.

9.1 Anchoring system

The packed equipment is secured to the support pallet through the holes on the frame and indicated in the figure below. These holes can be used to secure the equipment to the floor, using suitable concrete anchors (not included). Before concrete anchoring to floor, check that all the anchor points are flat, or level in contact with the floor. If not, shim between the equipment and the floor, as indicated in **Fig. 7**.

- To secure the equipment to the floor, use anchoring bolts/studs (**Fig. 7 ref. 1**) with a threaded shank M10 (UNC 3/8 - 16) suitable for the floor on which the tyre changer will be secured and in a number equal to the number of mounting holes on the bottom frame;
- drill holes in the floor, suitable for inserting the chosen anchors, in correspondence with the holes on the bottom frame;
- insert the anchors into the holes drilled in the floor through the holes on the bottom frame and tighten the anchors;
- tighten the anchors on the base frame and torque as indicated by the manufacturer of the anchors.

Fig. 7

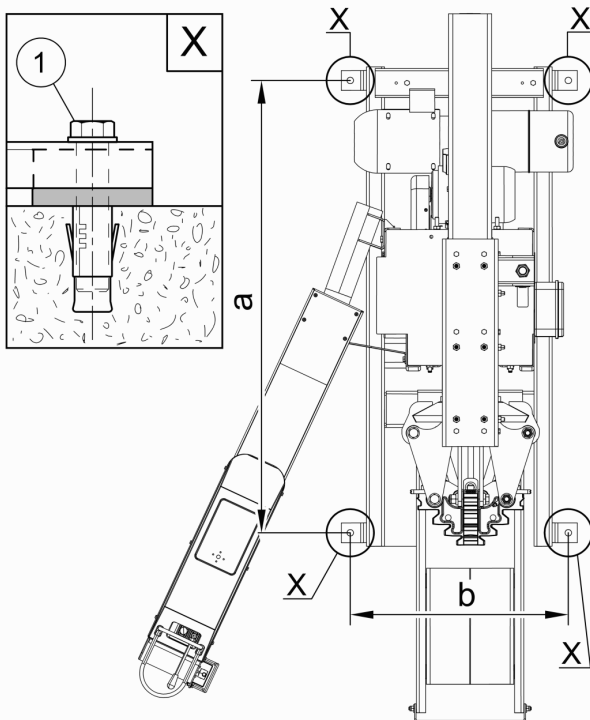

a = 1255 mm / 49.41"
b = 600 mm / 23.62"

10.0 ELECTRICAL CONNECTIONS



ALL ELECTRICAL CONNECTIONS ARE TO BE DONE BY QUALIFIED PERSONNEL ONLY.



BEFORE CONNECTING THE EQUIPMENT MAKE SURE THAT:

- POWER LINE SPECIFICATIONS CORRESPOND TO EQUIPMENT REQUIREMENTS AS SHOWN ON THE MACHINE NAMEPLATE;
- ALL MAIN POWER COMPONENTS ARE IN GOOD CONDITION;
- THE ELECTRICAL SYSTEM IS PROPERLY GROUNDED (GROUND WIRE MUST BE THE SAME CROSS-SECTION AREA AS THE LARGEST POWER SUPPLY CABLES OR GREATER);
- MAKE SURE THAT THE ELECTRICAL SYSTEM FEATURES A PADLOCKABLE MAIN SWITCH AND A CUTOUT WITH DIFFERENTIAL PROTECTION SET AT 30 mA.

The equipment is supplied with a cable. A plug corresponding to the following requirements must be connected to the cable:



FIT A TYPE-APPROVED (AS REPORTED BEFORE) PLUG TO THE EQUIPMENT CABLE (THE GROUND WIRE IS YELLOW/GREEN AND MUST NEVER BE CONNECTED TO ONE OF THE PHASE LEADS OR TO THE NEUTRAL).



MAKE SURE THAT THE ELECTRICAL SYSTEM IS COMPATIBLE WITH THE RATED POWER REQUIREMENTS SPECIFIED IN THIS MANUAL AND APT TO ENSURE THAT VOLTAGE DROP UNDER FULL LOAD WILL NOT EXCEED 4% OF RATED VOLTAGE (10% UPON START-UP).



FAILURE TO OBSERVE THE ABOVE INSTRUCTIONS WILL IMMEDIATELY INVALIDATE THE WARRANTY AND MAY DAMAGE THE EQUIPMENT.

Motor power supply	Conformity standard	Voltage	Amperage	Poles	Minimum IP rating
3 Ph power supply	IEC 309	200/230/400 V	16 / 16 / 10 A	3P + Ground	IP 44

10.1 Oil check on oil-pressure power unit



THE OIL-PRESSURE POWER UNIT IS DELIVERED WITHOUT HYDRAULIC OIL, THEREFORE MAKE SURE THE TANK PROVIDED IS FILLED WITH AN APPROXIMATE AMOUNT OF OIL OF 3 LITRES (0.79 GALLONS), BEING CAREFUL NOT TO SPILL IT OUTSIDE THE TANK.

USE HYDRAULIC OIL WITH A VISCOSITY DEGREE APPROPRIATE TO THE AVERAGE TEMPERATURES IN THE INSTALLATION COUNTRY AND IN PARTICULAR:

- VISCOSITY 32 (OR COUNTRIES WITH ROOM TEMPERATURE FROM 0 °C - +30 °C (+32 °F - +86 °F));
- VISCOSITY 46 (FOR COUNTRIES WITH ROOM TEMPERATURE ABOVE +30 °C degrees (+86 °F)).

10.2 Check of motor rotation direction

Once the last electrical connection has been completed, power the equipment with the main switch. Make sure the motor of the hydraulic unit rotates in the direction indicated by the arrow (Fig. 8 ref. B) visible on the electric motor cap. If rotation should occur in the opposite direction, the equipment must be immediately stopped and phase inversion must be executed inside the plug connection in order to reset the correct rotation direction.



FAILURE TO OBSERVE THE ABOVE INSTRUCTIONS WILL IMMEDIATELY INVALIDATE THE WARRANTY.

10.3 Electrical checks



BEFORE STARTING UP THE TYRE-CHANGER, BE SURE TO BECOME FAMILIAR WITH THE LOCATION AND OPERATION OF ALL CONTROLS AND CHECK THEIR PROPER OPERATION (SEE PAR. "CONTROLS").



CARRY OUT A DAILY CHECK OF THE HOLD-TO-RUN CONTROL CONTROLS FOR PROPER FUNCTIONING, BEFORE STARTING EQUIPMENT OPERATION.

Once the plug/socket connection has been made, turn on the equipment using the main switch (Fig. 8 ref. A).

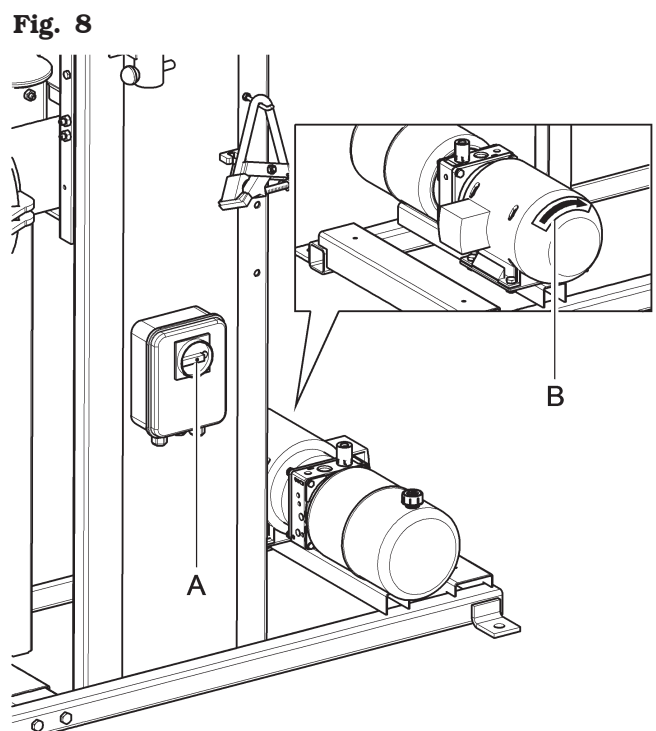

KEY
 A - Main switch
 B - Direction rotation of oil-pressure power unit motor



ONCE THE ASSEMBLY OPERATIONS HAVE BEEN COMPLETED, CHECK ALL EQUIPMENT FUNCTIONS.

11.0 CONTROLS

11.1 Control device

The control (handle control) can be moved according to the positioning necessities of the operator.

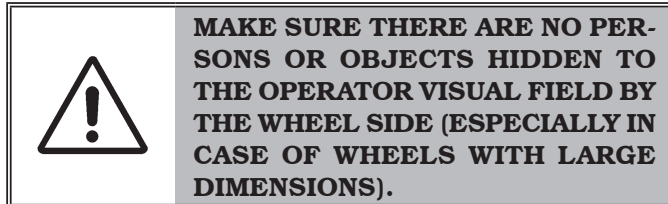

The control (**Fig. 12**) consists of:

- **“A” lower selector** (with guard) for wheel holder self-centring chuck open/close control with three positions: one central position “stable” to stop self-centring chuck open/close movement and two positions “with maintained control” to open/close self-centring chuck jaws (NAV26HW);
- **“B” lever** for tool holder tool/bead breaker roller movement control with three-positions: one central position “stable” to stop movement and two positions “with maintained control” for tool/bead breaking roller support movement towards the right or towards the left (from work position “C” **Fig. 6**);
- **“C” lever** three-positions control for vertical movement of self-centring chuck arm: central “firm” position for movement stop and two “hold activation” positions for arm up and down movement;
- **“D” lever** control self-centring chuck anticlockwise/clockwise rotation.

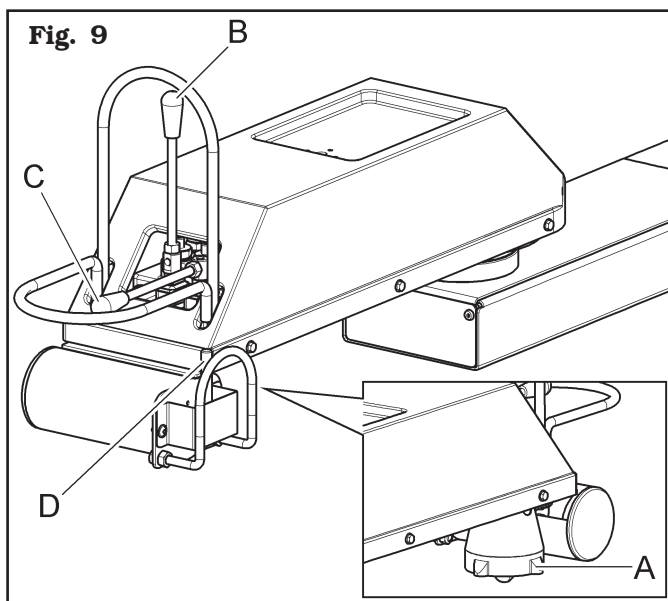

12.0 USE OF THE EQUIPMENT

12.1 Precaution measures during tyre removal and fitting



Before fitting a tyre, observe the following safety rules:

- rim and tyre must always be clean, dry and in good condition; if necessary, clean the rims and check that:
 - neither the beads, the sidewalls nor the tread of the tyre are damaged;
 - the rim does not have any dents and/or deformations (especially for alloy rims, dents can cause internal micro-fractures, that pass unobserved at visual inspection, and can compromise the solidity of the rim and constitute danger even during inflation);
- adequately lubricate the contact surface of rim and the tyre beads, using specific tyre lubricants only;
- replace the rim valve with a new valve. if the tyre pipe has a metal valve, replace the grommet.
- always make sure that tyre and rim sizes are correct for their coupling; never fit a tyre unless you are sure it is of the right size (the rated size of rim and tyre is usually printed directly on them);
- do not use compressed air or water jets to clean the wheels on the equipment.



FITTING A TYRE WITH A DAMAGED BEAD, TREAD AND/OR SIDEWALL ON A WHEEL RIM REDUCES THE SAFETY OF A VEHICLE AND CAN LEAD TO TRAFFIC ACCIDENTS, SERIOUS INJURY OR EVEN DEATH.

IF A TYRE BEAD, TREAD OR SIDEWALL IS DAMAGED DURING REMOVAL, NEVER REFIT THE TYRE ONTO A WHEEL.

IF YOU SUSPECT THAT A BEAD, TREAD OR SIDEWALL OF A TYRE MAY HAVE BEEN DAMAGED DURING FITTING, REMOVE THE TYRE AND INSPECT IT CAREFULLY. NEVER REFIT IT TO A WHEEL IF A BEAD, TREAD OR SIDEWALL IS DAMAGED.



THE USE OF AN INADEQUATE, WORN OR OTHERWISE DAMAGED LEVER TO REMOVE TYRE BEADS MAY LEAD TO DAMAGE TO A BEAD AND/OR A TYRE SIDEWALL, REDUCING THE SAFETY OF A VEHICLE EQUIPPED WITH THE TYRE ITSELF.

ONLY USE THE LEVER SUPPLIED WITH THE EQUIPMENT AND CHECK ITS CONDITION BEFORE EACH DISASSEMBLY.

IF IT IS WORN OR OTHERWISE DAMAGED, DO NOT USE IT TO REMOVE THE TYRE, BUT REPLACE IT WITH A LEVER SUPPLIED BY THE EQUIPMENT MANUFACTURER OR ONE OF ITS AUTHORIZED DISTRIBUTORS.



INADEQUATE LUBRICATION OF THE TYRE, THE RIM, THE TOOL-HEAD AND/OR THE LEVER CAN CAUSE AN ABNORMAL FRICTION BETWEEN THE TYRE AND THESE ELEMENTS DURING THE DISASSEMBLY AND/OR ASSEMBLY OF THE TYRE AND CAUSE DAMAGE TO THE TYRE ITSELF, REDUCING THE SAFETY OF A VEHICLE EQUIPPED WITH THE TYRE.

ALWAYS LUBRICATE THESE ELEMENTS THOROUGHLY USING A SPECIFIC LUBRICANT FOR TYRES, FOLLOWING THE INDICATIONS CONTAINED IN THIS MANUAL.



FAILURE TO INSERT A SUITABLE SECTION OF A BEAD INSIDE THE RIM DROP CENTRE, AS INDICATED IN THIS MANUAL DURING THE FITTING OR REMOVAL OF THE BEAD, RESULTS IN AN ABNORMAL TENSION ON THE BEAD.

THIS CAN CAUSE DAMAGE TO THE BEAD AND/OR THE SIDEWALL OF THE TYRE TO WHICH THE BEAD IS CONNECTED, REDUCING THE SAFETY OF A VEHICLE EQUIPPED WITH THE TYRE.

ALWAYS FOLLOW THE DIRECTIONS IN THE MANUAL REGARDING ALIGNMENT OF A SECTION OF A BEAD TO THE RIM DROP CENTRE.

DO NOT PROCEED WITH THE REMOVAL OR INSTALLATION OF A BEAD IF YOU ARE NOT ABLE TO ALIGN A SECTION OF A BEAD WITH THE RIM DROP CENTRE AS INDICATED IN THIS MANUAL.



AN INCORRECT POSITIONING OF THE VALVE AT THE BEGINNING OF THE DISASSEMBLY AND/OR ASSEMBLY OPERATIONS OF EACH TYRE BEAD CAN CAUSE THE VALVE TO BE, DURING THESE OPERATIONS, IN OR NEAR AN AREA WHERE THE BEAD HAS FITTED INTO THE RIM DROP CENTRE. THE BEAD COULD PRESS ON THE PRESSURE SENSOR, LOCATED UNDER THE VALVE INSIDE THE DROP CENTRE, CAUSING IT TO BREAK. ALWAYS RESPECT THE POSITIONING OF THE VALVE AT THE BEGINNING OF EACH BEAD DISASSEMBLY AND/OR ASSEMBLY OPERATION INDICATED IN THIS MANUAL.

12.2 Preliminary operations

In view of the tyre changer structure and of its intended use, the operator must work with large diameter and heavy tyres/wheels.

The utmost care while moving the wheels is recommended: make use of other operators, properly trained and with suitable clothes.



THE CAREFUL LUBRICATION OF THE TYRE BEADS IS RECOMMENDED, IN ORDER TO PROTECT THEM FROM POSSIBLE DAMAGES AND TO FACILITATE MOUNTING AND DEMOUNTING OPERATIONS.

12.3 Preparing the wheel

- Remove the wheel balancing weights from both sides of the wheel;



REMOVE THE VALVE STEM AND ALLOW THE TYRE TO COMPLETELY DEFLATE.

- establish from which side the tyre should be demounted, checking the position of the drop centre;
- find the rim locking type.



WHEN HANDLING WHEELS WEIGHING MORE THAN 500 kg (1102.5 lbs) A FORK-LIFT TRUCK OR A CRANE SHOULD BE USED.

12.4 Wheel clamping



DUE TO THE SIZE AND WEIGHT OF THE WHEEL/TYRE, MAKE USE OF A SECOND OPERATOR TO HOLD THE WHEEL INTO VERTICAL POSITION, IN ORDER TO ENSURE SAFE OPERATIVE CONDITIONS.



MAKE SURE THAT RIM CLAMPING IS DONE PROPERLY AND THAT THE GRIP IS SECURE, TO PREVENT THE WHEEL FROM FALLING DURING MOUNTING OR REMOVAL OPERATIONS.



DO NOT CHANGE THE SET OPERATING PRESSURE VALUE USING THE MAXIMUM PRESSURE VALVES. THE MANUFACTURER SHALL NOT BE RESPONSIBLE FOR INJURY OR DAMAGE ARISING FROM UNAUTHORISED CHANGES.

Fig. 10

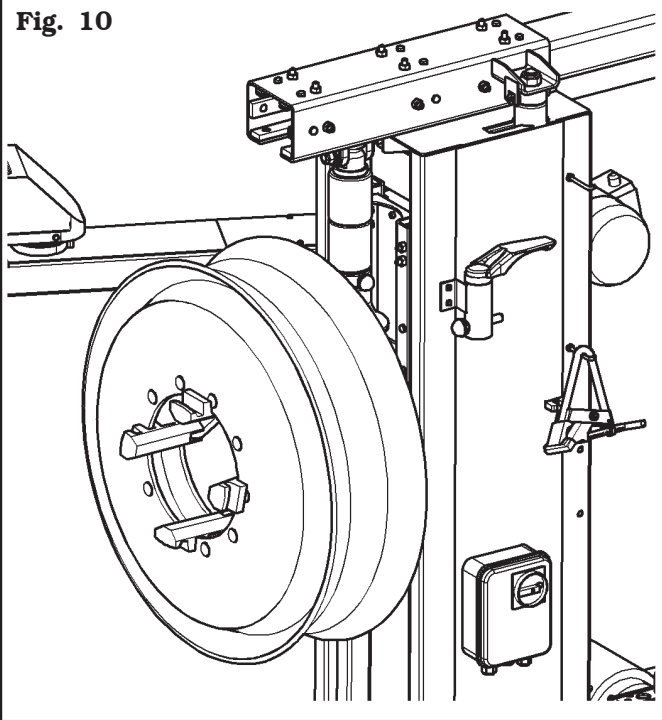

Clamping on the central hole

All wheels must be clamped from the inside.



CLAMPING ON THE CENTRAL FLANGE IS ALWAYS SAFEST.



FOR WHEELS WITH DROP CENTRE RIMS SECURE THE WHEEL SO THAT THE DROP CENTRE IS FACING OUTWARDS COMPARED TO THE SELF-CENTRING CHUCK.



IF IT IS NOT POSSIBLE TO CLAMP THE RIM IN THE HOLE OF THE DISC, CLAMP ON THE BEAD SEAT CLOSE TO THE DISC.



TO SECURE WHEELS WITH ALLOY RIMS ADDITIONAL PROTECTIVE JAWS ARE AVAILABLE. THEY ALLOW YOU TO WORK ON THE RIMS WITHOUT DAMAGING THEM. THE PROTECTIVE JAWS ARE FITTED ONTO SELF-CENTRING CHUCK NORMAL JAWS USING A BAYONET CONNECTION.

Fig. 11

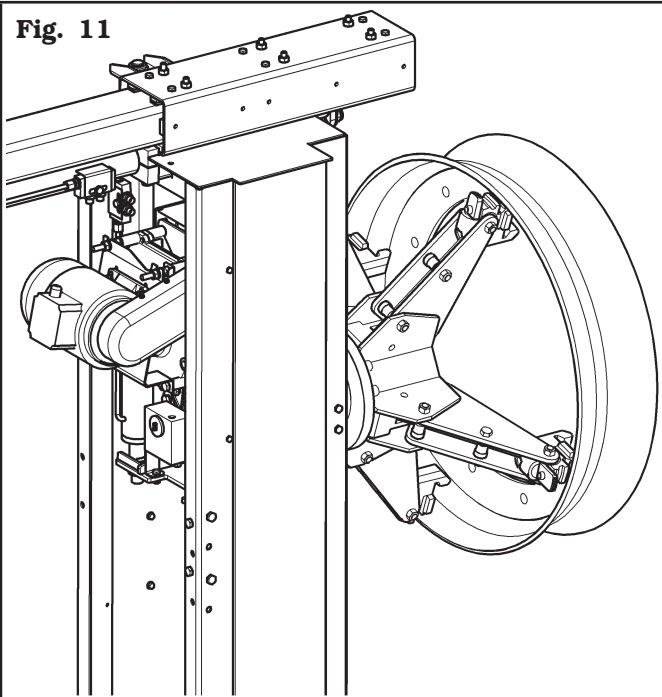

Clamping on bead seat



THE OPENING/CLOSING MOVEMENT OF THE SELF-CENTRING CHUCK GENERATES A GREAT DEAL OF COMPRESSIVE FORCE DURING THE WHEEL LOCKING/UNLOCKING PHASE. KEEP HANDS/FINGERS OR ANY PART OF THE BODY AWAY FROM MOVING CLAMPS AT ALL TIMES.

To clamp the wheel proceed as follows:

- place the wheel in vertical position not far from the self-centring chuck;
- use the lever (**Fig. 9 ref. C**) to place the coaxial self-centring chuck with the wheel centre, in order to make jaws edges skim the wheel edge;
- adjust the opening of the self-centring chuck through the corresponding control (**Fig. 9 ref. A**) according to the type of rim to be locked;
- operate the control (**Fig. 9 ref. A**) until the wheel is completely clamped;
- check both that the rim is clamped and centred correctly, and that the wheel has been raised above from the floor, so that it does not slip during the following operations.



KEEP ON OPERATING RIM CLAMPING CONTROL, UNTIL REACHING THE MAX. OPERATING PRESSURE (130 bar - 1885 psi).



THE CAREFUL LUBRICATION OF THE TYRE BEADS IS RECOMMENDED, IN ORDER TO PROTECT THEM FROM POSSIBLE DAMAGES AND TO FACILITATE MOUNTING AND DEMOUNTING OPERATIONS.



AFTER COMPLETION OF TYRE MOUNT/DEMOUNT OPERATIONS DO NOT LEAVE THE WHEEL CLAMPED ON THE SELF-CENTRING CHUCK AND NEVER LEAVE IT UNATTENDED.

12.5 Functioning of roller holder arm

During the working phases, the roller holder arm can maintain two firm positions, that is:

1. "Working" position;
2. "out of work" position.

In "working" position (**Fig. 12 ref. 1**) the roller holder arm is lowered towards the self-centring chuck and from this position it must carry out the various tyre bead breaking, demounting and mounting operations.

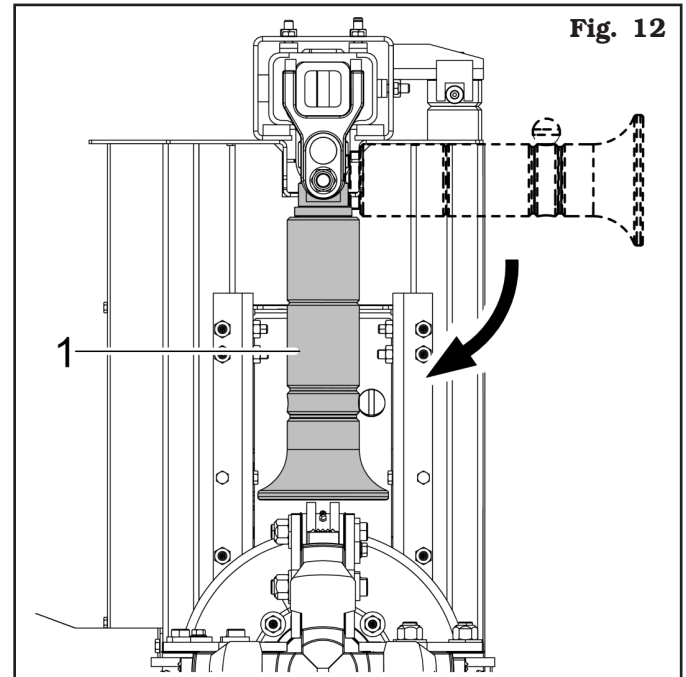

In "out of work" position (**Fig. 13 ref. 1**): the roller holder arm is in horizontal position and has to be brought in this position every time it is not in use and in order to be shifted from one tyre side to another, during the different working phases.

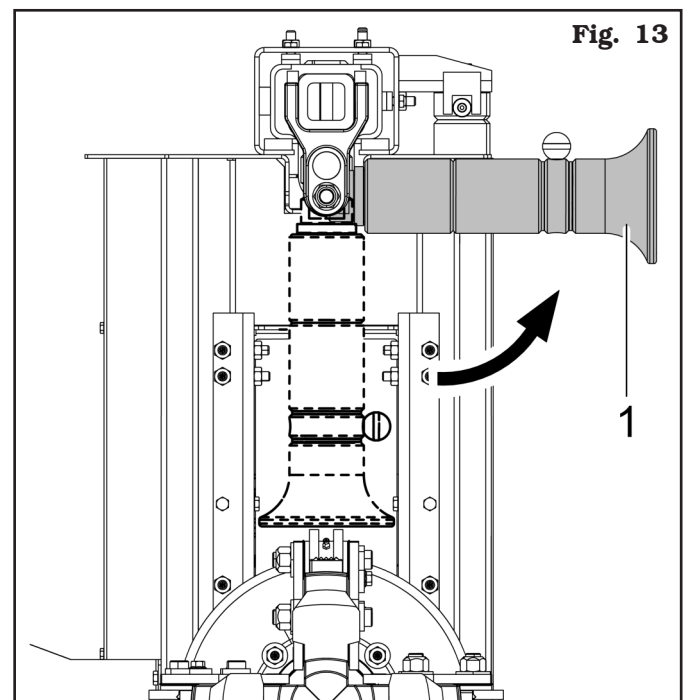



The roller holder arm, shifts from “out of work” position to “working” position and vice versa manually.

 **IN “WORK POSITION” OR “OUT OF WORK POSITION”, THE SAFETY PIN (FIG. 1 REF. 12) HAS TO BE INSERTED INTO THE APPROPRIATE HOUSING.**

12.6 Tubeless tyres

12.6.1 Bead breaking

 **NEVER PLACE ANY PART OF YOUR BODY BETWEEN THE BEAD BREAKER ROLLER AND THE TYRE.**

 **THROUGHOUT TYRE MOUNTING/DEMOUNTING OPERATIONS, CHECK THAT THE WHEEL IS FIRMLY CLAMPED BY THE EQUIPMENT SELF-CENTRING CHUCK.**

1. Lock the wheel on the self-centring chuck as described in the previous paragraph;
2. remove all balancing weights from the rim. Extract the valve and let air out of tyre;
3. move to work position A (Fig. 6);
4. position the bead breaker roller on the external side of the tyre;

 **ALWAYS VERIFY THAT THE ARM IS CORRECTLY LOCKED TO THE SHIFTING BEAM.**

5. lift the self-centring chuck (Fig. 14 ref. 1) by using the appropriate handle control, until bringing the bead breaker roller (Fig. 14 ref. 2) next to the tyre brim (Fig. 14 ref. 3), in contact with the external bead;

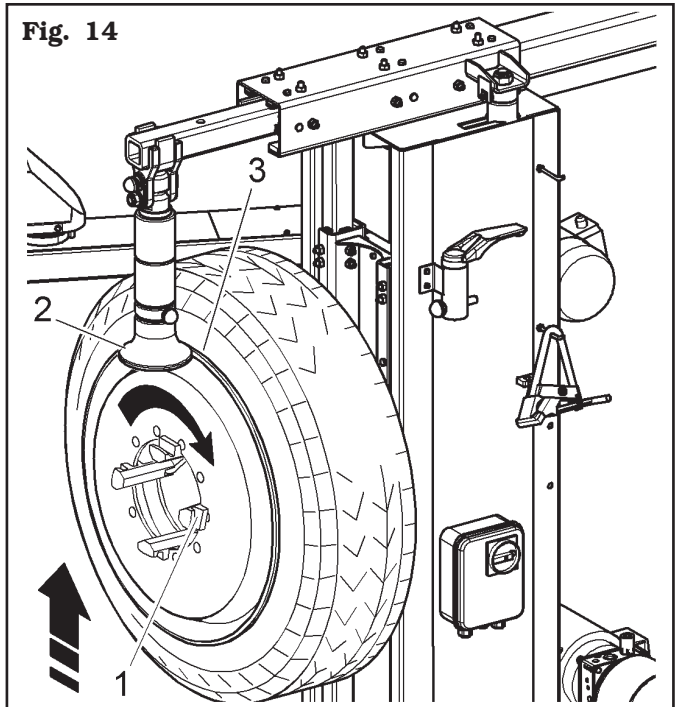

 **THE BEAD BREAKER ROLLER MUST NOT EXERT PRESSURE ON THE RIM BUT ON THE TYRE BEAD.**

6. turn the self-centring chuck counterclockwise and, at the same time, gradually move the roller (Fig. 15 ref. 1) inwards to bead the tyre. Carry on with self-centring chuck rotation, while generously lubricating tyre rim and bead with a suitable lubricant. The more the tyre adheres to the rim; the slower should the beading roller advance.

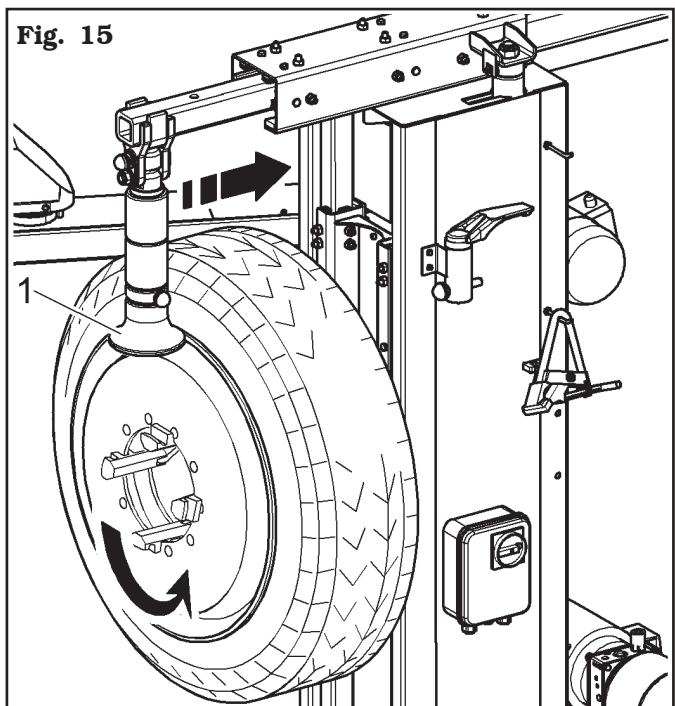



USE ONLY TYRE LUBRICANTS. SUITABLE LUBRICANTS CONTAIN NO WATER, HYDROCARBONS, OR SILICON.

7. once external beading has been carried out, unhook and lift the roller holder arm setting it to “out of work” position (**Fig. 13 ref. 1**); use the handle control to position the roller holder arm on the inner side of the wheel, then set it to “work position” (**Fig. 12 ref. 1**) and secure it with the special safety pin;



FOR WHEELS WITH MAX. DIAMETER LOWER THAN 1100 mm (43.31”), IT IS POSSIBLE TO SHIFT THE BEAD BREAKER ROLLER INTO THE SAME REAR BEADING POSITION BY LOWERING THE WHEEL (SEE FIG. 16) IN ORDER TO BRING IT BACK TO BEADING POSITION (SEE FIG. 17).

Fig. 17

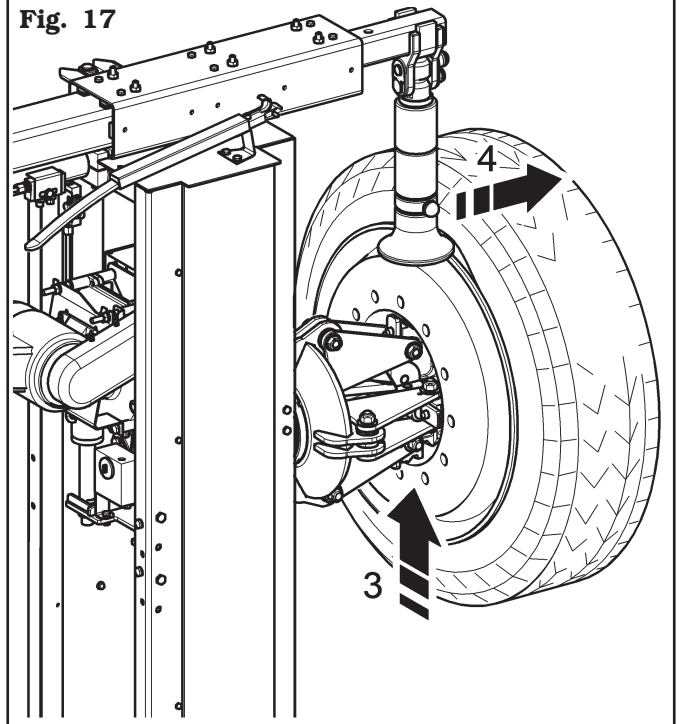
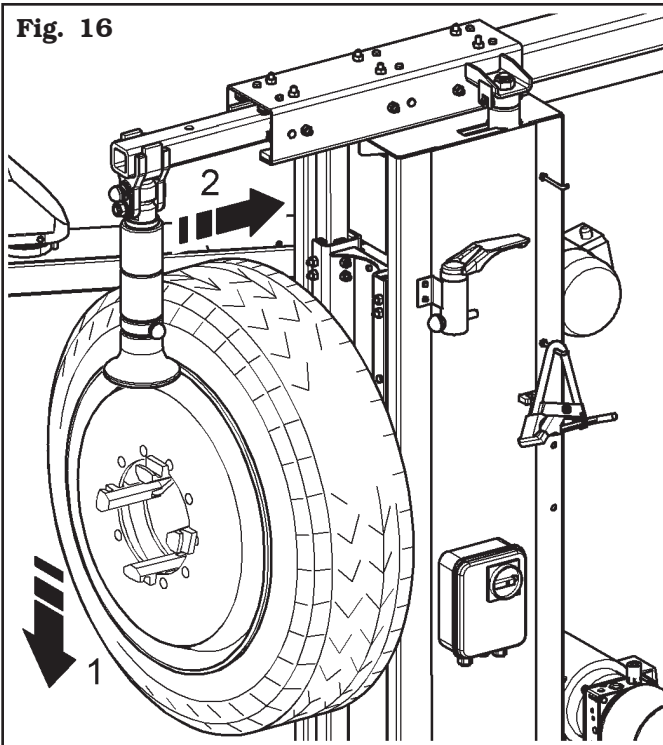

Fig. 16



PAY ATTENTION WHEN REPOSITIONING THE ROLLER HOLDER ARM TO AVOID HAND CRUSHING.

8. Move to work position **C** (**Fig. 6**) and repeat the operations described in point **6** until the tyre has been completely beaded.

12.6.2 Demounting



THROUGHOUT TYRE MOUNTING/DEMOUNTING OPERATIONS, CHECK THAT THE WHEEL IS FIRMLY CLAMPED BY THE EQUIPMENT SELF-CENTRING CHUCK.

Tubeless tyres can be removed in two ways:

1. if the wheel does not present particular problems, continuing beading operation will completely dislodge the beads from the rim. The inner bead, pushed by the roller, presses against the outer one till it has been completely removed (see **Fig. 18**);

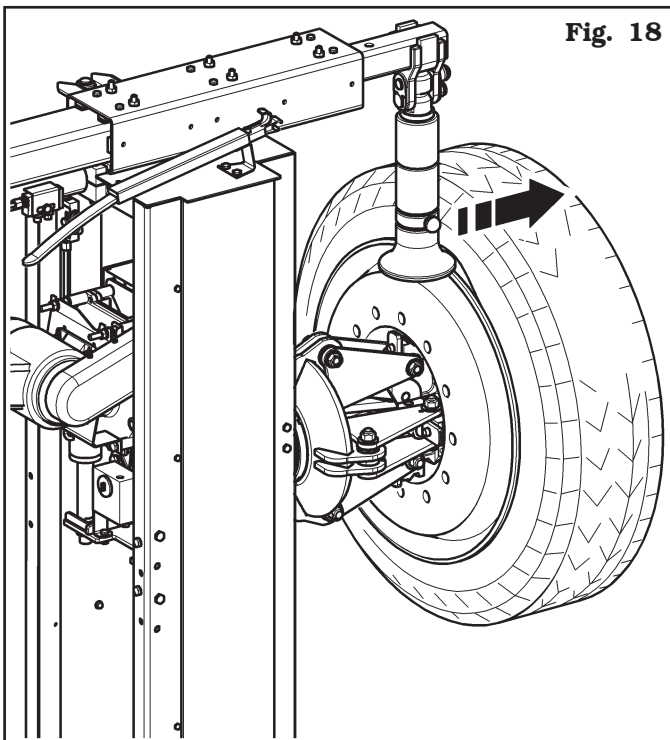
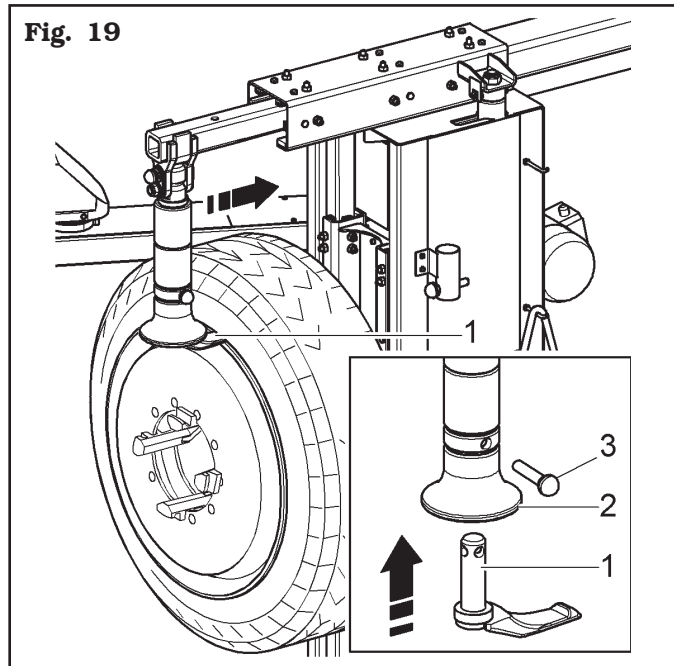

Fig. 18

2. if the wheel is especially hard, it is not possible to carry out the procedure described in point 1. A different procedure will be necessary: use the hook tool and follow this sequence of operations:

- move to work station **A** (**Fig. 6**);
- position the roller holder arm on the outer side of the wheel;
- put the hook tool (**Fig. 19 ref. 1**) into the roller (**Fig. 19 ref. 2**), as shown in **Fig. 19**, and block it in position by inserting the pin (**Fig. 19 ref. 3**);
- bring forward the hook, inserting it between the rim and the bead until it is secured to the bead itself (see **Fig. 19**).

Fig. 19



- move the rim away downwards from the bead breaker roller by about 4-5 cm (1.57" - 1.97") to avoid possible unhooking of the bead from the same roller.
- translate the bead breaker roller outwards (**Fig. 20 ref. 2**) to allow easy insertion of lever (**Fig. 20 ref. 1**) between the rim and the bead; insert lever (**Fig. 20 ref. 1**) between the rim and the bead on the right-hand side of the bead breaker roller (**Fig. 20 ref. 2**);

Fig. 20

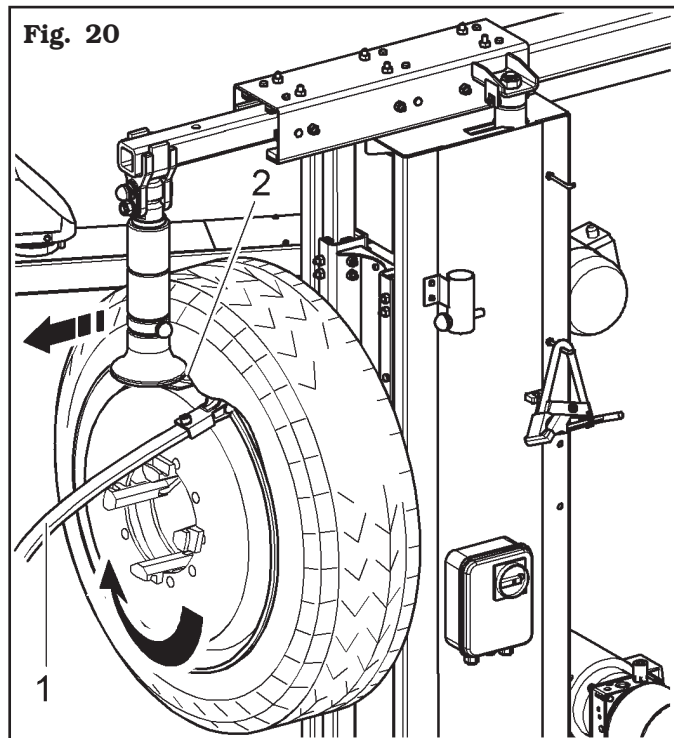

- keeping the lever pressed, lift the wheel until the edge of the rim is 5 mm distant (0.20") from the hook tool;
- rotate the wheel clockwise until the bead has completely gone out;

- once the external bead has been removed, move roller holder arm away from the wheel, unhook it and lift it setting it to "out of work" position (**Fig. 13 ref. 1**); use the handle control to position the roller holder arm on the inner side of the wheel then set it to work position again (**Fig. 12 ref. 1**) and secure with the safety pin;



WHEN THE BEADS COME OUT OF THE RIM THE TYRE MAY FALL. ALWAYS MAKE SURE THAT NO ONE IS STANDING BY ACCIDENT IN THE WORK AREA.



PAY ATTENTION WHEN REPOSITIONING THE ROLLER HOLDER ARM TO AVOID HAND CRUSHING.



WHEN DEMOUNTING VERY HEAVY TYRES IT IS ADVISABLE TO PAY CAREFUL ATTENTION BEFORE COMPLETING THE OPERATION.



ALWAYS MAKE SURE THAT THE ARM IS CORRECTLY LOCKED TO THE SHIFTING BEAM.

- move to work position **C** (**Fig. 6**);
- take the pin off (**Fig. 21 ref. 1**), turn the hook tool (**Fig. 21 ref. 2**) 180° and block it again with the pin (**Fig. 21 ref. 1**) in order to be able to insert the tool itself (**Fig. 21 ref. 2**) between the rim edge and the bead of the tyre;

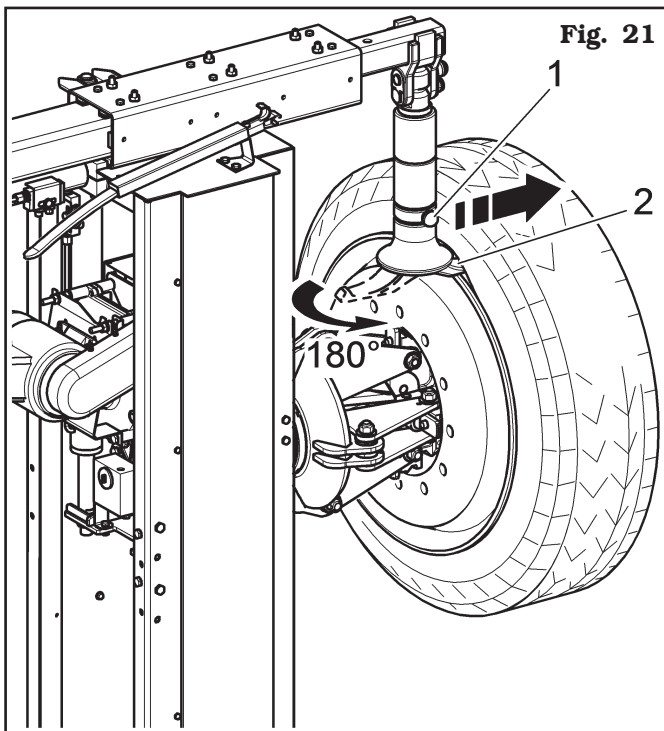

- move the rim away downwards from the tool by about 4-5 cm (1.57" - 1.97") to avoid possible unhooking of the bead from the same tool;
- move to work position **B** (**Fig. 5**);
- translate the hook tool towards the external rim edge, then turn the self-centring chuck clockwise until the tyre has been completely removed;

12.6.3 Mounting

THROUGHOUT TYRE MOUNTING/DEMOUNTING OPERATIONS, CHECK THAT THE WHEEL IS FIRMLY CLAMPED BY THE EQUIPMENT SELF-CENTRING CHUCK.

Tubeless tyre fitting is normally done with the roller tool; if the wheel is especially hard to fit, use the hook tool.

With bead breaker roller

Proceed as follows:

1. secure the rim to the self-centring chuck according to the procedure described in "WHEEL CLAMPING" paragraph;
2. adequately lubricate tyre beads and rim bead seats with a suitable lubricant using the supplied brush;

USE ONLY TYRE LUBRICANTS. SUITABLE LUBRICANTS CONTAIN NO WATER, HYDROCARBONS, OR SILICON.

3. mount clamp for alloy rims (optional) (Fig. 22 ref. 1) on the external edge of the rim at the highest point, as shown in Fig. 22;

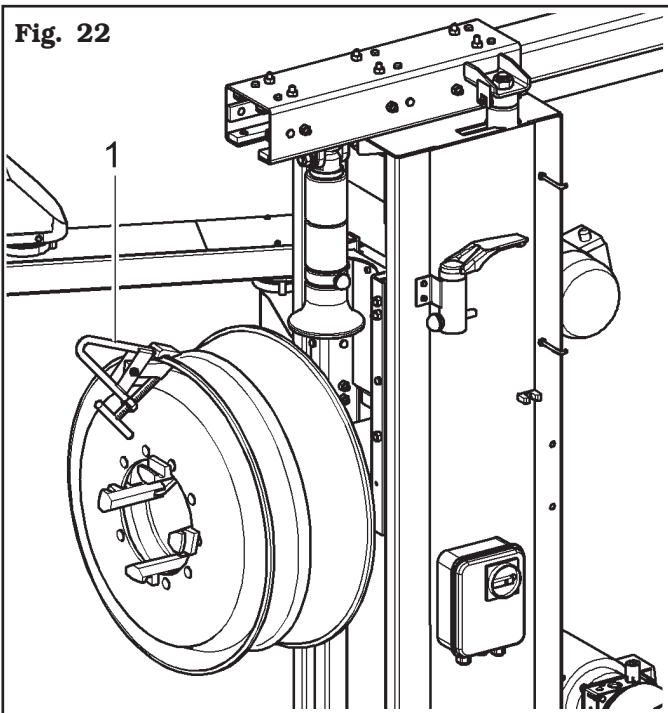

THE CLAMP FOR ALLOY RIMS (OPTIONAL) MUST BE TIGHTLY SECURED TO THE EDGE OF THE RIM.

4. move to work position B (Fig. 5);
5. completely lower self-centring chuck. Roll the tyre on the floor and hook it to the clamp for alloy rims (optional) (Fig. 23 ref. 1);
6. lift the self-centring chuck with the tyre hooked and turn it clockwise 15-20 cm (5.91"-7.87"); the tyre will position itself sideways in relation to the rim (see Fig. 23);

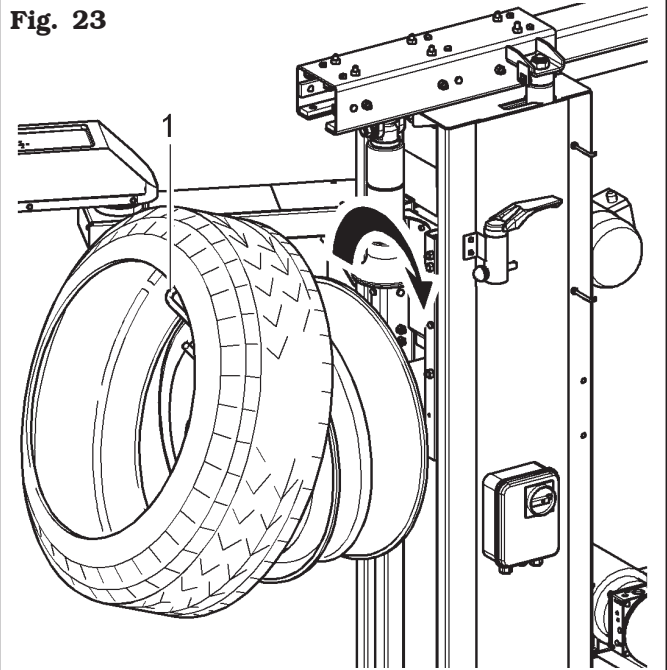

7. position the bead breaker roller (Fig. 24 ref. 2) so that it is at approximately 1.5 cm (0.59") from the edge of the rim. The clamp for alloy rims (optional) (Fig. 24 ref. 1) is in the "1 o'clock" position. Turn the self-centring chuck clockwise until bringing the clamp for alloy rims (optional) to the closest point to the bead breaker roller ("11 o'clock").

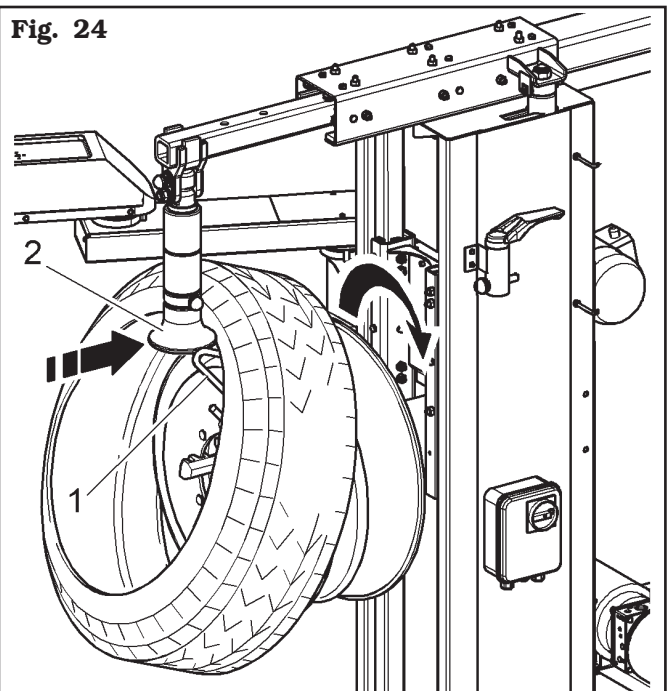

8. move the bead breaker roller away from the wheel;
9. remove the clamp for alloy rims (optional) and fit it in position ("6 o'clock") outside the second bead;
10. turn self-centring chuck counterclockwise until clamp for alloy rims (optional) is at "1 o'clock";
11. move the bead breaker roller forward until it is inside the edge of the rim by about 1-2 cm (0.39" - 0.79"), making sure it is approximately 5 mm (0.2") from rim edge. Start clockwise rotation making sure that, after a 90° turn, the second bead begins sliding in the rim drop;
12. once insertion is completed, move the roller away from the wheel, turn it over into "out of work" position and remove clamp for alloy rims (optional);
13. lower self-centring chuck until the wheel rests on the floor;
14. move to work position **A** (**Fig. 6**);
15. close self-centring chuck jaws completely, making sure the wheel is held up to avoid dropping;



MAKE SURE THAT THE WHEEL'S HOLD IS SECURE TO AVOID IT FALLING DURING REMOVAL. FOR HEAVY AND/OR VERY LARGE WHEELS USE AN ADEQUATE LIFTING DEVICE.

16. remove the wheel from the equipment by making it roll. By using particularly soft tyres, it is possible to put on the rim both beads at the same time, in order to operate only one time on the tyre.

With hook tool

Proceed as follows:

1. secure the rim to the self-centring chuck according to the procedure described in "WHEEL CLAMPING" paragraph;
2. adequately lubricate tyre beads and rim bead seats with a suitable lubricant using the supplied brush;



USE ONLY TYRE LUBRICANTS. SUITABLE LUBRICANTS CONTAIN NO WATER, HYDROCARBONS, OR SILICON.

3. mount clamp for alloy rims (optional) (**Fig. 22 ref. 1**) on the external edge of the rim at the highest point;



THE CLAMP FOR ALLOY RIMS (OPTIONAL) MUST BE TIGHTLY SECURED TO THE EDGE OF THE RIM.

4. move to work position **B** (**Fig. 6**);
5. completely lower self-centring chuck. Roll the tyre just next to self-centring chuck and hook it to the clamp for alloy rims (optional) (**Fig. 23 ref. 1**);
6. lift the self-centring chuck with the tyre hooked and turn it clockwise 15-20 cm (5.91" - 7.87"); the tyre will position itself sideways in relation to the rim (see **Fig. 23**);
7. set the roller holder arm to "out of work" position (**Fig. 13 ref. 1**); translate it to the inner side of the tyre and set it to "work position" again (**Fig. 12 ref. 1**);
8. mount the hook tool on the roller, by positioning it on the side of the tyre (see **Fig. 25**);

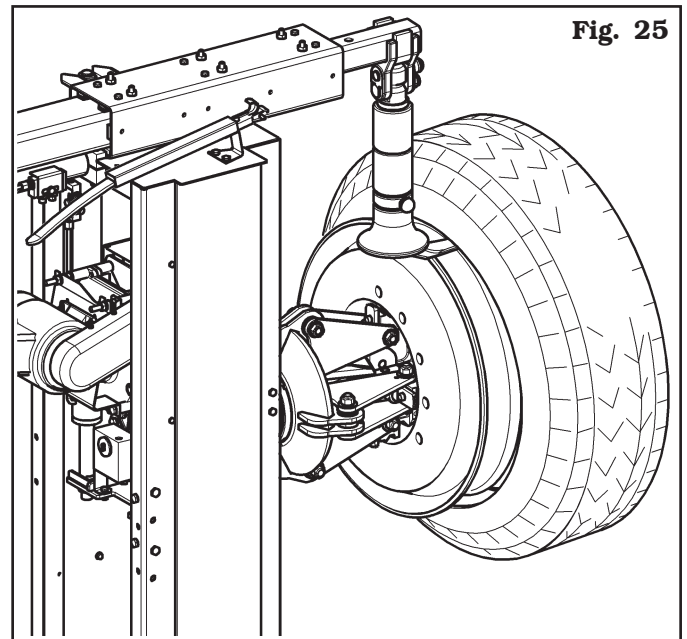



Fig. 25

9. move to work position **C** (**Fig. 6**);
10. move the tool forward until the reference notch matches the external edge of the rim coincide at about 5 mm (0.2") from the rim itself;
11. move to work position **B** (**Fig. 6**);
12. from the external side of the wheel, check the exact position of the tool and, if necessary, correct it. Then, turn the self-centring chuck clockwise until clamp for alloy rims (optional) reaches the closest point to the tool ("11 o'clock"). The first bead should now be inserted in the rim;
13. remove the clamp for alloy rims (optional);
14. move to work position **C** (**Fig. 6**);

15. extract the tool from the tyre;
16. set the roller holder arm to “out of work” position (**Fig. 13 ref. 1**); translate it to the outer side of the tyre and set it to “work position” again (**Fig. 12 ref. 1**);
17. mount the tool head again at 180° until the hook tool is moved onto the tyre side (see **Fig. 19**);
18. mount the clamp for alloy rims (optional) and fit it in the lowest point (6 o'clock) outside the second bead;
19. move to work position **B** (**Fig. 6**);
20. turn self-centring chuck counterclockwise until clamp for alloy rims (optional) is at “1 o'clock”;
21. move the tool forward until the axis of the reference notch matches that of the external edge of the rim at about 5 mm (0.2”) from the rim itself (**Fig. 19**). Begin clockwise rotation making sure that, after a 90° turn, the second bead begins to slide in the rim drop centre. Turn until clamp for alloy rims (optional) reaches the closest point to the tool (“11 o'clock”). The second bead should now be inserted in the rim;
22. move the tool away from the wheel, turn it over into “out of work” position and remove clamp for alloy rims (optional);
23. lower self-centring chuck until the wheel rests on the floor;
24. move to work position **A** (**Fig. 6**);
25. close self-centring chuck jaws completely, making sure the wheel is held up to avoid dropping;



MAKE SURE THAT THE WHEEL IS SECURELY CLAMPED TO AVOID IT FALLING DURING REMOVAL. FOR HEAVY AND/OR VERY LARGE WHEELS USE AN ADEQUATE LIFTING DEVICE.

26. remove the wheel from the equipment by making it roll.

12.7 Tyres with inner tube

12.7.1 Bead breaking



REMOVE THE RING NUT OF THE INNER TUBE VALVE TO ALLOW ITS EXTRACTION DURING TYRE REMOVAL PHASES; REMOVE THE NUT WHEN DEFLATING THE TYRE.

The beading procedure is the same one described for tubeless tyres.



WHEN BEADING WHEELS WITH INNER TUBES, INTERRUPT THE FORWARD MOVEMENT OF THE BEAD BREAKER ROLLER AS SOON AS THE BEADS HAVE BEEN DISLODGED TO AVOID DAMAGE TO THE INNER PIPE OR TO THE VALVE.

12.7.2 Demounting



THROUGHOUT TYRE MOUNTING/DEMOUNTING OPERATIONS, CHECK THAT THE WHEEL IS FIRMLY CLAMPED BY THE EQUIPMENT SELF-CENTRING CHUCK.

1. Bring roller holder arm to “out of work” position (**Fig. 13 ref. 1**); use the handle control to position the roller holder arm on the outer side of the wheel then set it to work position (**Fig. 12 ref. 1**) and secure with the safety pin provided (**Fig. 1 e 2 ref. 12**);



PAY ATTENTION WHEN REPOSITIONING THE ROLLER HOLDER ARM TO AVOID HAND CRUSHING.



ALWAYS MAKE SURE THAT THE ARM IS CORRECTLY LOCKED TO THE SHIFTING BEAM.

2. mount the hook tool turned towards the tyre in order to insert the same hook between rim edge and tyre bead; the operation must be carried out during the self-centring chuck rotation;

3. move the rim away downwards from the tool by about 4-5 cm (1.57" - 1.97") to avoid possible unhooking of the bead from the same tool;
4. translate the hook tool outwards until the reference notch matches the external edge of the rim;
5. move to work position **A** (**Fig. 6**);
6. insert lever (**Fig. 26 ref. 1**) between the rim and the bead on the right-hand side of the tool;

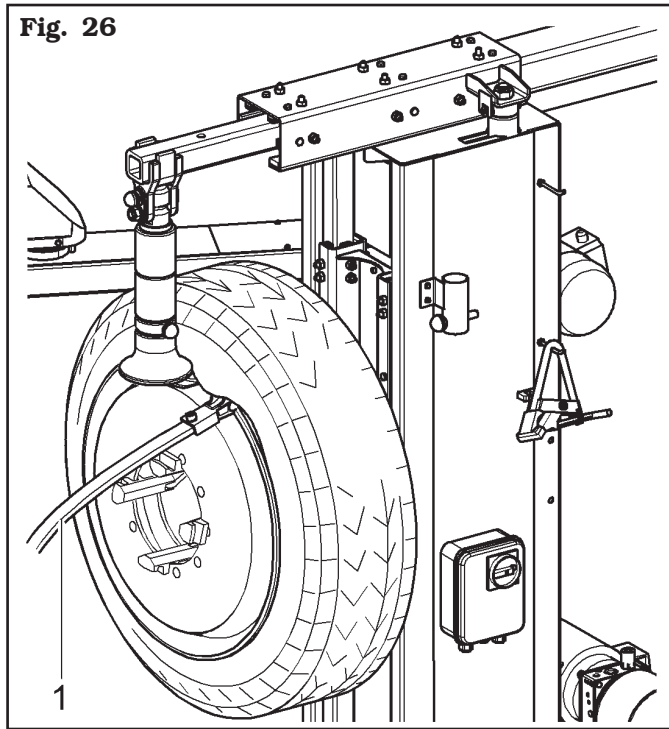

7. keeping the lever pressed lift the wheel until the edge of the rim is 5 mm (0.2") distant from the hook tool;
8. turn the wheel clockwise by keeping lever pressed until the bead has gone completely out;
9. move the roller holder arm away to "out of work" position (**Fig. 13 ref. 1**); lower the self-centring chuck until placing the tyre on the ground; exert a certain pressure on it; this will create the space required to extract the inner tube;
10. extract the inner tube and lift the wheel again;
11. move to work position **C** (**Fig. 6**);
12. unhook and lift the roller holder arm setting it to "out of work" position (**Fig. 13 ref. 1**); use the handle control to position the roller holder arm on the inner side of the wheel then set it to work position (**Fig. 12 ref. 1**) and secure with the safety pin provided (**Fig. 1 and 2 ref. 12**);
13. mount the hook tool again with a 180° rotation, according to the descriptions in the relevant paragraph, in order to insert the hook between rim edge and tyre bead; the operation must be carried out during self-centring chuck rotation;

14. move the rim away downwards from the tool by about 4-5 cm (1.57" - 1.97") to avoid possible unhooking of the bead from the same tool;
15. move to work position **A** (**Fig. 6**);
16. translate the hook tool outwards until the reference notch is 3 cm (1.18") inside the rim;
17. insert the lever (**Fig. 27 ref. 1**) between rim (**Fig. 27 ref. 2**) and bead (**Fig. 27 ref. 3**) on the tool left hand side;

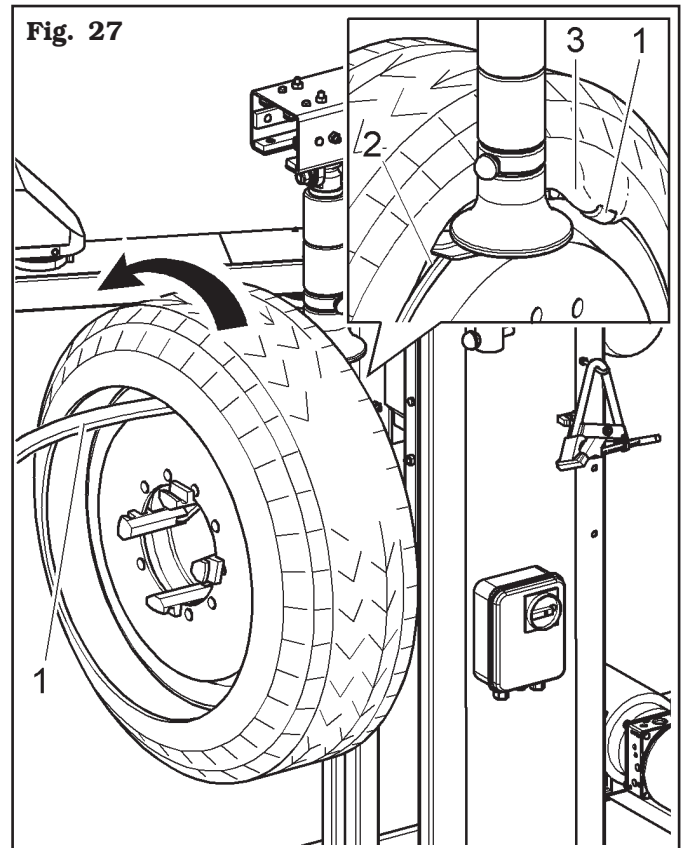

18. keeping the lever pressed, lift the wheel until the edge of the rim is approximately 5 mm (0.2") distant from the hook tool then turn the self-centring chuck counterclockwise keeping the lever (**Fig. 27 ref. 1**) pressed until the tyre has been completely dislodged from the rim.



WHEN THE BEADS COME OUT OF THE RIM THE TYRE MAY FALL. ALWAYS MAKE SURE THAT NO ONE IS STANDING BY ACCIDENT IN THE WORK AREA.



WHEN DEMOUNTING VERY HEAVY TYRES IT IS ADVISABLE TO PAY CAREFUL ATTENTION BEFORE COMPLETING THE OPERATION.

12.7.3 Mounting

 **THROUGHOUT TYRE MOUNTING/DEMOUNTING OPERATIONS, CHECK THAT THE WHEEL IS FIRMLY CLAMPED BY THE EQUIPMENT SELF-CENTRING CHUCK.**

1. Secure the rim to the self-centring chuck according to the procedure described in "WHEEL CLAMPING" paragraph;
2. adequately lubricate tyre beads and rim bead seats with a suitable lubricant using the supplied brush;

 **USE ONLY TYRE LUBRICANTS. SUITABLE LUBRICANTS CONTAIN NO WATER, HYDROCARBONS, OR SILICON.**

3. mount clamp for alloy rims (optional) (**Fig. 22 ref. 1**) on the external edge of the rim at the highest point, as shown in **Fig. 22**;

 **THE CLAMP FOR ALLOY RIMS (OPTIONAL) MUST BE TIGHTLY SECURED TO THE EDGE OF THE RIM.**

4. move to work position **B (Fig. 6)**;
5. position the tyre near the equipment and lower the self-centring chuck (make sure the clamp for alloy rims (optional) is at the highest point) to hook the first tyre bead (internal bead);
6. lift the self-centring chuck with the tyre hooked and turn it clockwise about 15-20 cm (5.91"- 7.87"); the tyre will position itself sideways in relation to the rim;
7. set the roller holder arm to "out of work" position (**Fig. 13 ref. 1**); operate the handle control in order to position the roller holder arm on the wheel inner side, then set it to "work position" (**Fig. 12 ref. 1**) again and lock it with the safety pin provided;

 **PAY ATTENTION WHEN REPOSITIONING THE ROLLER HOLDER ARM TO AVOID HAND CRUSHING.**

 **ALWAYS MAKE SURE THAT THE ARM IS CORRECTLY LOCKED TO THE SHIFTING BEAM.**

8. mount the hook tool turned towards the tyre in order to insert the same hook between rim edge and tyre bead; the operation must be carried out during the self-centring chuck rotation;
9. move to work position **C (Fig. 6)**;
10. move the tool forward until the axis of the reference notch matches that of the external edge of the rim at about 5 mm (0.2") from the rim itself (see **Fig. 28**);

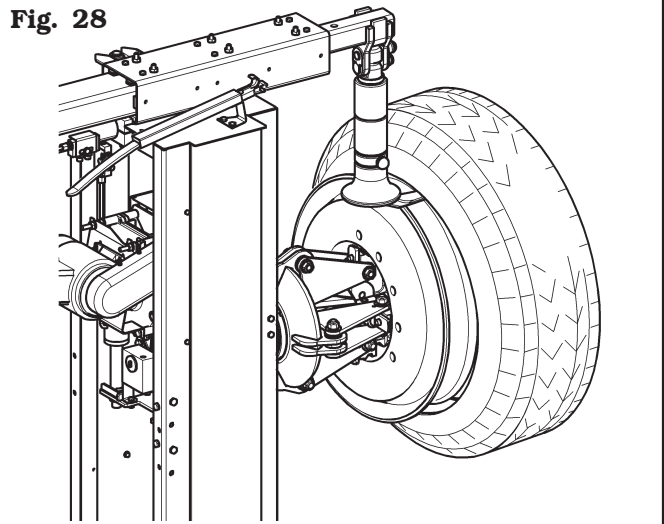

11. move to work position **B (Fig. 6)**;
12. from the external side of the wheel, check the exact position of the tool and, if necessary, correct it. Then, turn the self-centring chuck clockwise until clamp for alloy rims (optional) reaches the closest point to the tool ("11 o'clock"). The first bead should now be inserted in the rim, then remove clamp for alloy rims (optional);
13. move to work position **C (Fig. 6)**;
14. extract the tool hook from the tyre;
15. place the tool holder roller to "out of work" position (**Fig. 13 ref. 1**) and translate it to the outer side of the tyre;
16. mount the hook tool again with a 180° rotation, according to the descriptions in the relevant paragraph;
17. move to work position **A (Fig. 6)**;
18. turn self-centring chuck until the hole for valve introduction is downwards ("6 o'clock");
19. lower self-centring chuck until the wheel is laid down to the ground in order to create the space needed between tyre edge and rim for the inner tube introduction;

 **THE VALVE HOLE COULD BE IN AN ASYMMETRIC POSITION WITH RESPECT TO THE CENTRE OF THE RIM. IN THIS CASE IT IS NECESSARY TO POSITION AND INTRODUCE THE INNER TUBE AS SHOWN IN FIG. 29.**

Introduce the valve in the hole and secure it with the provided ring nut. Introduce the inner tube in the drop centre of the rim (to make this operation easier, it is advisable to simultaneously turn self-centring chuck clockwise).

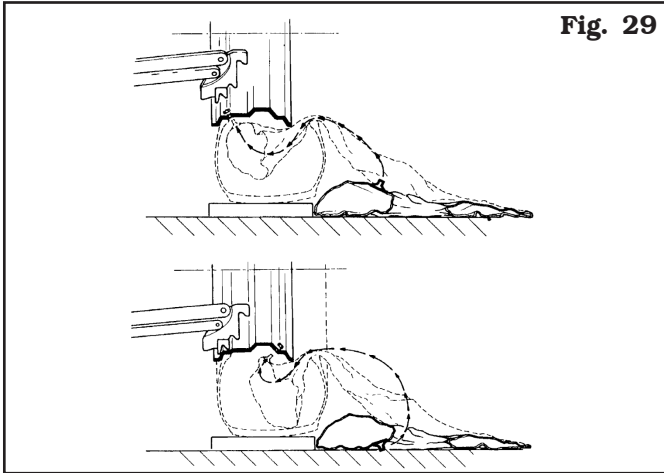

Fig. 29

20. turn self-centring chuck and position the valve downwards ("6 o'clock");
21. to avoid damaging the inner tube, slightly inflate it when inserting the second bead;
22. to avoid damaging the valve when securing the second bead, remove the fixing ring nut and mount an extension on the same valve;
23. move to work position **B** (**Fig. 6**);
24. lift the self-centring chuck and mount the clamp for alloy rims (optional) (**Fig. 30 ref. 1**) on the rim outside the second bead at about 20 cm (7.87") from the inflating valve on the right;
25. turn self-centring chuck counterclockwise until clamp for alloy rims (optional) (**Fig. 30 ref. 1**) is at "1 o'clock";

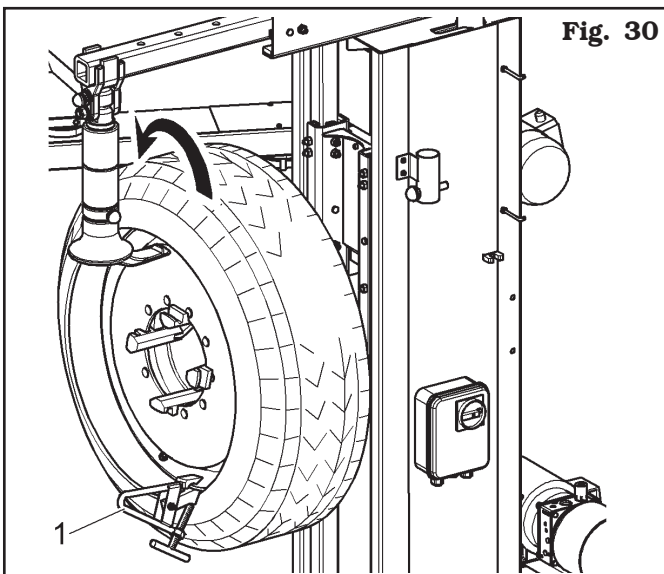

Fig. 30

26. set the roller holder arm to "work position" (**Fig. 12 ref. 1**) on the outer side of the tyre;

27. set the hook tool to work position and bring the roller holder arm forward until the axis of the reference notch matches that of the outer edge of the rim at a distance of 5 mm (0.2");
28. turn self-centring chuck clockwise until lever (**Fig. 31 ref. 1**) is introduced in the housing obtained on the hook tool;
29. turn the self-centring chuck clockwise with lever (**Fig. 31 ref. 1**) hooked up to the complete insertion of the tyre outer bead.
30. remove lever (**Fig. 31 ref. 1**), clamp for alloy rims (optional) (**Fig. 31 ref. 2**) and extract the hook tool by turning the self-centring chuck counterclockwise and translating it outwards;

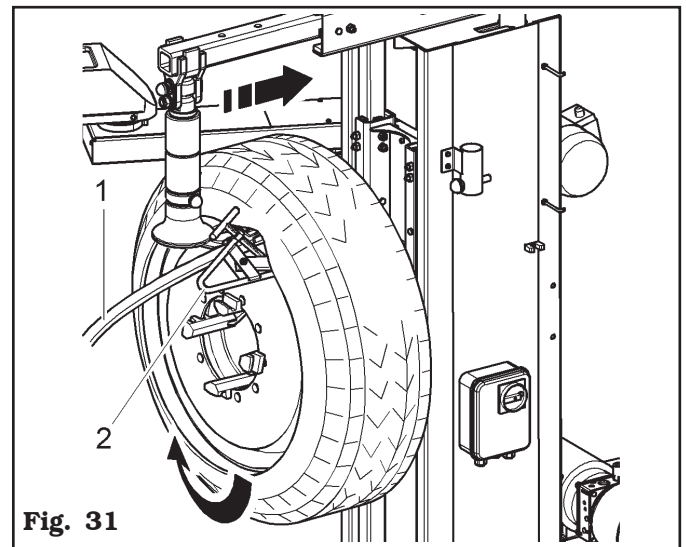

Fig. 31

31. bring the roller holder arm to "out of work" position (**Fig. 13 ref. 1**) after it has been unhooked;
32. lower self-centring chuck until the wheel rests on the floor;
33. move to work position **A** (**Fig. 6**);
34. check the state of the tyre valve and centre it, if necessary, in the rim hole by slightly turning self-centring chuck; secure the valve with the supplied ring nut after having removed the protective extension.
35. close self-centring chuck jaws completely, making sure the wheel is held up to avoid dropping;



MAKE SURE THAT THE WHEEL'S HOLD IS SECURE TO AVOID IT FALLING DURING REMOVAL. FOR HEAVY AND/OR VERY LARGE WHEELS USE AN ADEQUATE LIFTING DEVICE.

36. remove the wheel from the equipment by making it roll.

13.0 ROUTINE MAINTENANCE



BEFORE CARRYING OUT ANY ROUTINE MAINTENANCE PROCEDURE, DISCONNECT THE EQUIPMENT FROM ITS POWER SUPPLY SOURCES, TAKING SPECIAL CARE OF THE ELECTRICAL PLUG/SOCKET CONNECTION.



BEFORE CARRYING OUT ANY MAINTENANCE OPERATIONS, MAKE SURE THERE ARE NO WHEELS CLAMPED ON THE SELF-CENTRING CHUCK AND THAT ALL SUPPLIES TO THE EQUIPMENT HAVE BEEN DISCONNECTED.



BEFORE REMOVING HYDRAULIC CIRCUIT FITTING OR HOSES, MAKE SURE THAT THERE ARE NO PRESSURISED FLUIDS PRESENT. PRESSURISED OIL SPILLS MAY CAUSE SERIOUS WOUNDS OR INJURIES.



BEFORE CARRYING OUT ANY MAINTENANCE WORK ON THE HYDRAULIC CIRCUIT, SET THE EQUIPMENT IN THE REST CONDITION.

To guarantee the efficiency and correct functioning of the equipment, it is essential to carry out daily or weekly cleaning and weekly routine maintenance, as described below.

Cleaning and routine maintenance must be conducted by authorized personnel and according to the instructions given below.

- Disconnect the equipment from the electrical and hydraulic power supplies before carrying out any cleaning or maintenance operations.
- Remove deposits of tyre powder and other waste materials with a vacuum.

DO NOT BLOW IT WITH COMPRESSED AIR.

- Periodically (preferably once a month) make a complete check on the controls, ensuring that they provide the specified actions.
- Every 100 working hours lubricate the sliding guides (self-centring chuck and roller holder arm).

- Periodically (preferably once a month), grease all moving parts of the equipment (see **Fig. 32**).

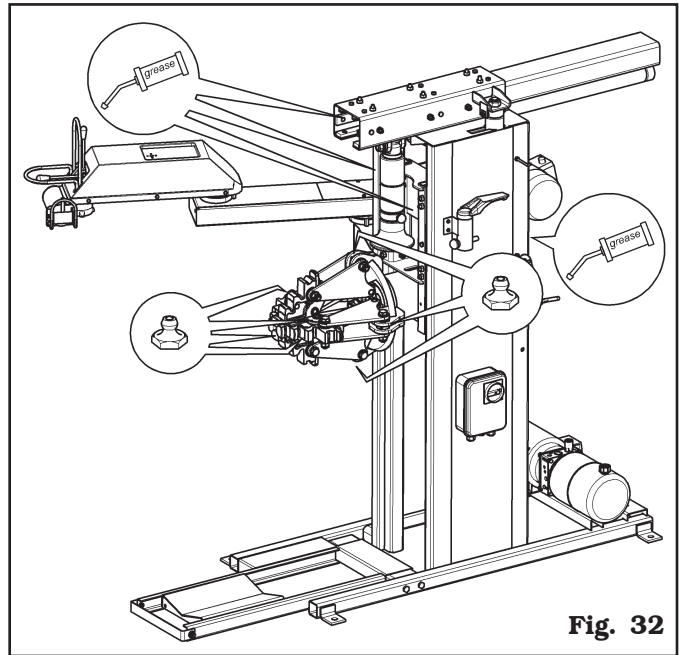



Fig. 32

- Check periodically the oil level of the oil-pressure unit and, in case, carry out the filling up with hydraulic oil having a viscosity degree suitable for the average temperatures of the country where the machine is installed and in particular:

- viscosity 32 (or countries with room temperature from 0 °C ÷ +30 °C (+32 °F ÷ +86 °F);
- viscosity 46 (for countries with room temperature above 30 degrees (+86 °F).

At least once a year it is advisable to proceed anyway to the complete replacement of the hydraulic oil of the same oil-pressure unit.



CARRY OUT THIS PROCEDURE WITH THE HYDRAULIC CYLINDERS COMPLETELY RETRACTED.

- Periodically (about every 100 hours), check the oil level of the reduction gear and eventually reset the level.
- Check operation of the safety devices every week.

A. Check belt tensioning (Fig. 33 ref. 1):

- Remove the protection guard (Fig. 33 ref. 2) with a screwdriver.
- Stretch the belt (Fig. 33 ref. 1) using the bolt (Fig. 33 ref. 3) after the nuts (Fig. 33 ref. 4); have been slackened.
- Tighten the fixing nuts (Fig. 33 ref. 4) after the adjustment operations, then assemble the protection guard (Fig. 33 ref. 2) again.

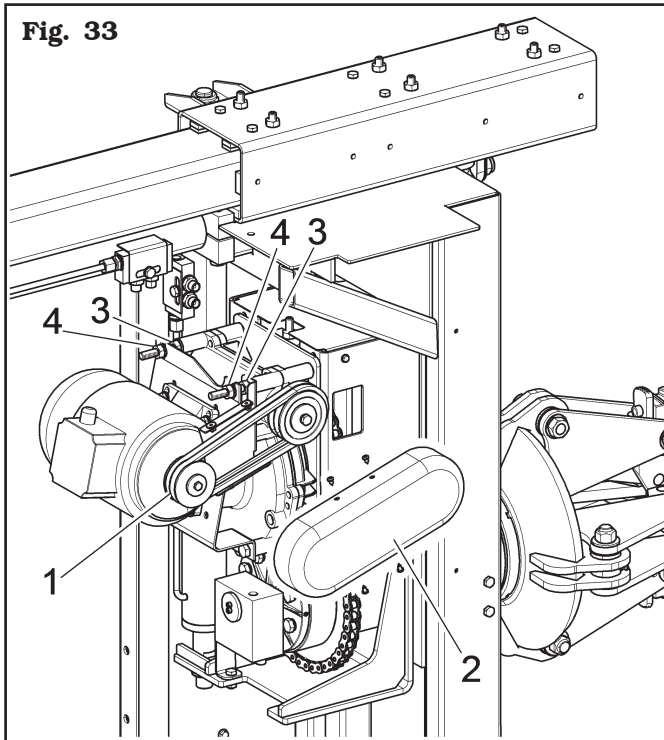

Fig. 33



OPERATION TO BE CARRIED OUT ONLY IN CASE THE ROLLER HOLDER ARM AND CARRIAGE ARE MOVING IN A NON-LINEAR WAY (STICK-SLIP MOTION).

B. Check periodically and, if necessary, adjust the play of slide (Fig. 34 ref. 1) on guide plates (Fig. 34 ref. 2) using the adjustment bolts (Fig. 34 ref. 3) of sliding blocks (Fig. 34 ref. 4).

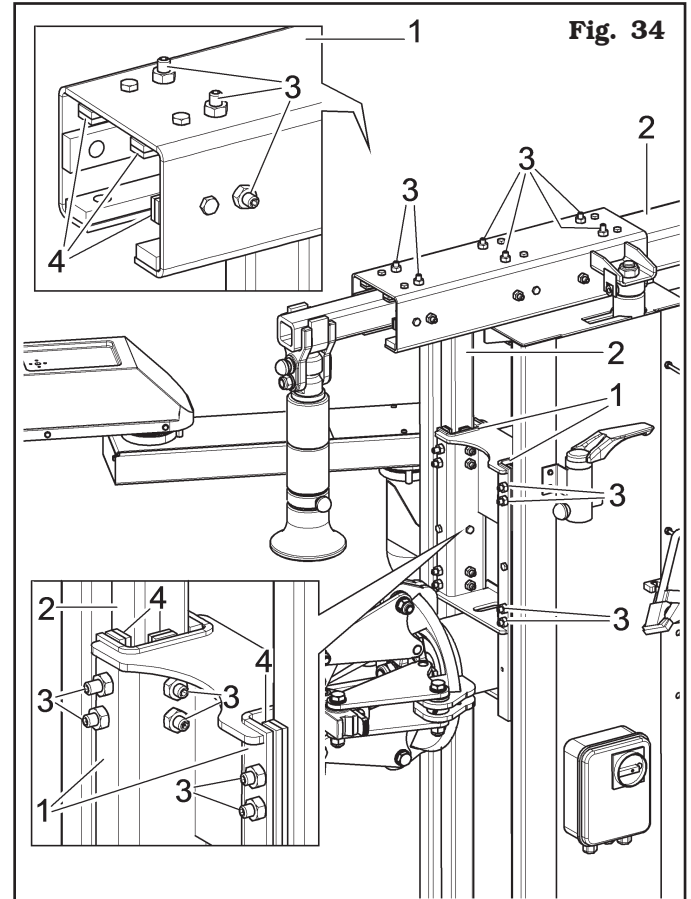

Fig. 34

- Periodically, every 50 working hours approximately, clean the (inner and outer) guides of self-centring chuck and of roller support arm.



ANY DAMAGE TO THE MACHINE DEVICES RESULTING FROM THE USE OF LUBRICANTS OTHER THAN THOSE RECOMMENDED IN THIS MANUAL WILL RELEASE THE MANUFACTURER FROM ANY LIABILITY!!



ANY EXTRAORDINARY MAINTENANCE OPERATION MUST BE CARRIED OUT EXCLUSIVELY BY PROFESSIONALLY QUALIFIED PERSONNEL.

14.0 TROUBLESHOOTING TABLE







Possible troubles which might occur to the tyre-changer are listed below. The manufacturer disclaims all responsibility for damages to people, animals or objects due to improper operation by non-authorized personnel. In case of trouble, call Technical Service Department for instructions on how to service and/or adjust the machine in full safety to avoid any risk of damage to people, animals or objects.



In an emergency and before maintenance on tyre-changer, set the main switch to "0" and lock it in this position.



CONTACT AUTHORIZED TECHNICAL SERVICE

do not try and service alone

Problem	Possible cause	Remedy
Pump motor does not work but wheel holder self-centring chuck motor works perfectly.	Hydraulic control unit damaged.	Call Technical Service Dept. 
When the switch is turned on, wheel holder self-centring chuck does not turn whereas pump motor works.	Gearmotor change-over switch damaged.	Call Technical Service Dept. 
Power drop during wheel holder self-centring chuck rotation.	Timing belt too loose.	Tension up the belt.
No pressure in the hydraulic system.	Pump damaged.	Replace pump. 
The self-centring chuck opening pressure does not go down.	Pressure limiting valve jammed	Download self-centring chuck (remove wheel), completely undo adjusting handle. Perform many opening and closing cycles up to jam release. 
The equipment does not start.	a) No power supply. b) Overload cutouts not set. c) Transformer fuse blown.	a) Connect the power supply. b) Set the overload cutouts. c) Change the fuse.
Fluid leaks from fitting or pipeline.	a) Fitting not tightened correctly. b) Pipeline cracked.	a) Tighten the fitting. b) Call the after-sales service. 
A control device is remaining on.	a) The switch has broken. b) A solenoid valve has jammed.	a) Call the after-sales service. b) Call the after-sales service. 
The self-centring chuck cylinder is losing pressure.	a) The directional control valve is leaking. b) The gaskets are worn.	a) Call the after-sales service. b) Call the after-sales service. 
The motor stops during operation.	Overload cutout tripped.	Open the electrical cabinet and reset the overload cutout tripped.

Problem	Possible cause	Remedy
When a control device is operated the equipment does not move at all.	<ul style="list-style-type: none"> a) Solenoid valve not receiving power. b) Solenoid valve jammed. c) Transformer fuse blown. d) Control unit not set correctly. 	<ul style="list-style-type: none"> a) Call the after-sales service. b) Call the after-sales service. c) Change the fuse. d) Call the after-sales service. 
No pressure in hydraulic circuit.	<ul style="list-style-type: none"> a) Oil-pressure power unit motor turning in wrong direction. b) Oil-pressure power unit pump is broken. c) No oil in oil-pressure power unit tank 	<ul style="list-style-type: none"> a) Restore correct rotation direction by changing socket connection. b) Call the after-sales service. c) Fill oil-pressure power unit tank with oil 
The equipment operates in jerks.	<ul style="list-style-type: none"> a) Not enough fluid in oil-pressure power unit tank. b) Control unit switch has failed. 	<ul style="list-style-type: none"> a) Top up with oil. b) Call the after-sales service. 

15.0 TECHNICAL DATA

15.1 Technical electrical data

Motor power (kW)		1.1 (1.5 Hp)		
Power supply	Voltage (V)	200	230	400
	Number of phases	3		
	Frequency (Hz)	50 / 60		
Hydraulic drive unit motor (kW)		0.75 (1 Hp)		
Power supply	Voltage (V)	200	230	400
	Phases	3		
	Frequency (Hz)	50 / 60		
Typical current draw (A)		16	16	10
Self-centring chuck rotation speed (rev/min)		8		

15.2 Technical mechanical data

Tyre maximum diameter (mm)	1300 (51")
Wheel max. width (mm)	950 (37")
Max. rotation torque (Nm)	1700 (1254 ft-lbs)
Wheel max. weight (kg)	1200 (2646 lbs)
Self-centring lock (inches)	11 - 27
Minimum locking hole (mm)	90 (3.54")
Self-centring chuck minimum height from the ground (mm)	330 (13")
Bead-breaking force (N)	16000 (3597 lbf)
Gear noise (dB) (A)	< 80
Operating pressure (bar)	130 (1885 psi)
Weight (kg)	350 (772 lbs)

15.3 Dimensions

Fig. 35

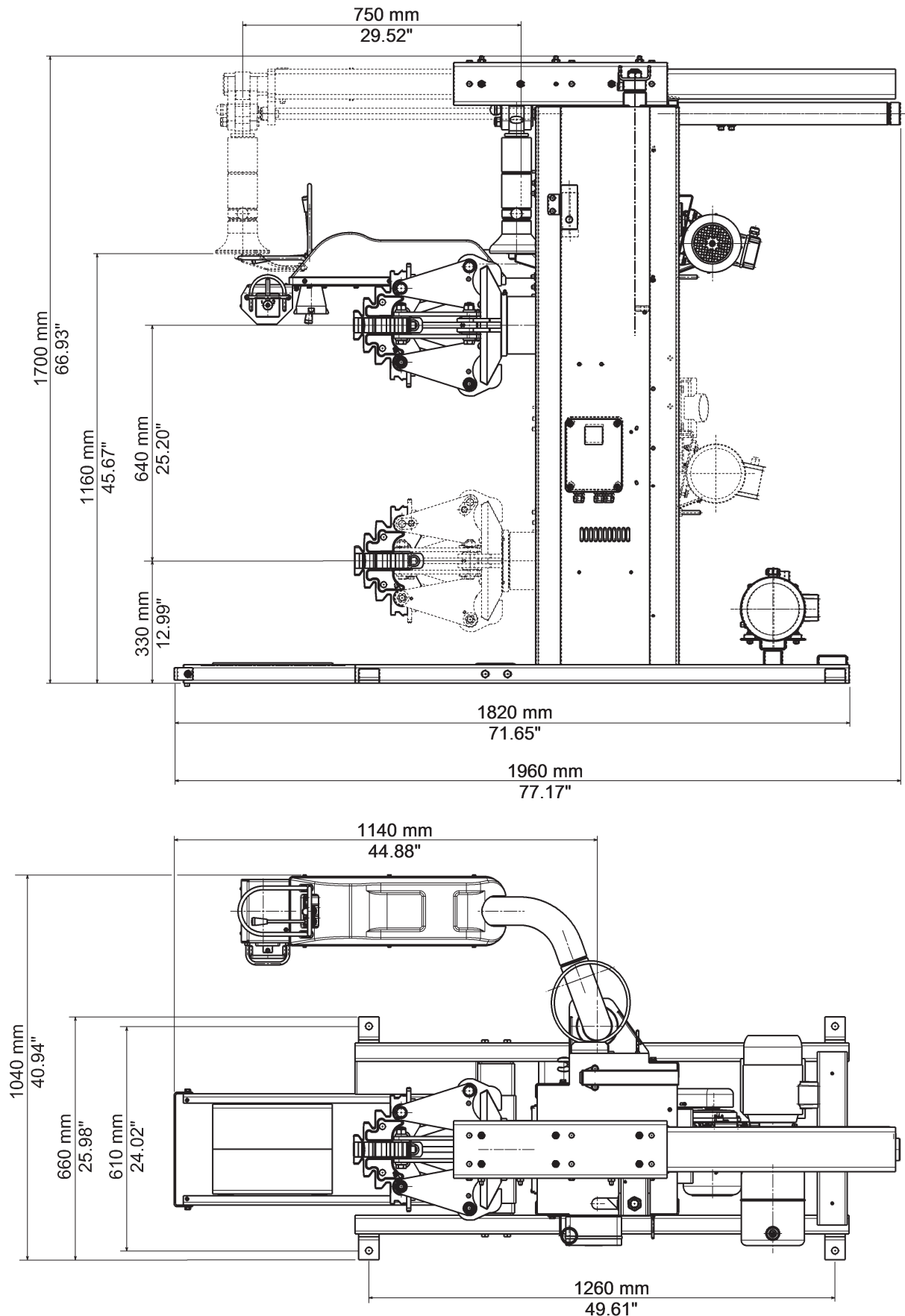

16.0 STORING

If storing for long periods disconnect the main power supply and take measures to protect the equipment from dust build-up. Lubricate parts that could be damaged from drying out. When putting the equipment back into operation replace the rubber pads and the toolhead.

17.0 SCRAPPING

When the decision is taken not to make further use of the equipment, it is advisable to make it inoperative by removing the connection pressure hoses. The equipment is to be considered as special waste and should be dismantled into homogeneous parts. Dispose of it in accordance with current legislation.

Instructions for the correct management of waste from electric and electronic equipment (WEEE) according to the Italian legislative decree 49/14 and subsequent amendments.

In order to inform the users on the correct way to dispose the equipment (as required by the article 26, paragraph 1 of the Italian legislative decree 49/14 and subsequent amendments), we communicate what follows: the meaning of the crossed dustbin symbol reported on the equipment indicates that the product must not be thrown among the undifferentiated rubbish (that is to say together with the “mixed urban waste”), but it has to be managed separately, to let the WEEE go through special operations for their reuse or treatment, in order to remove and dispose safely the waste that could be dangerous for the environment and to extract and recycle the raw materials to be reused.

18.0 REGISTRATION PLATE DATA

TYRE CHANGER MODEL	SERIAL N°	MONTH-YEAR
AMPERAGE	BAR	POWER SUPPLY

The validity of the Conformity Declaration enclosed to this manual is also extended to products and/or devices the equipment model object of the Conformity Declaration can be equipped with.

Said plate must always be kept clean from grease residues or filth generally.

ATTENTION: TAMPERING WITH, CARVING, CHANGING ANYHOW OR EVEN REMOVING EQUIPMENT IDENTIFICATION PLATE IS ABSOLUTELY FORBIDDEN; DO NOT COVER IT WITH TEMPORARY PANELS, ETC., SINCE IT MUST ALWAYS BE VISIBLE.

WARNING: Should the plate be accidentally damaged (removed from the equipment, damaged or even partially illegible) inform immediately the manufacturer.

19.0 FUNCTIONAL DIAGRAMS

Here follows a list of the equipment functional diagrams.

Fig. 36

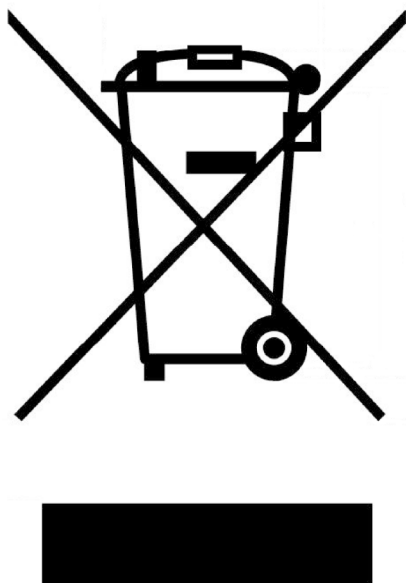

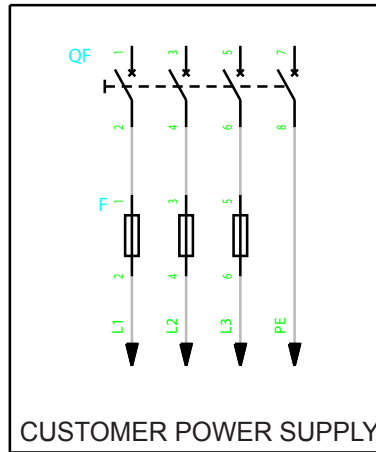
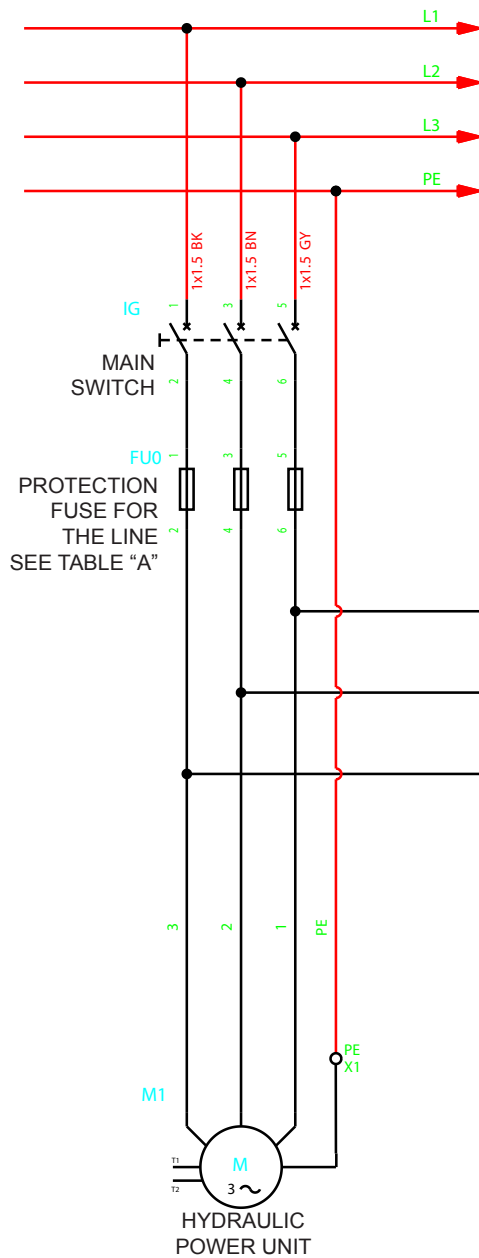

INSTALLATION CHARGED TO CUSTOMER

TABLE "A"

HZ \ V	V		
	200	230	400
50	16A aM	16A aM	10A aM
60	16A aM	16A aM	10A aM

3P+GROUND POWER CABLE X 1.5 mm²

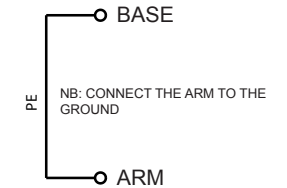
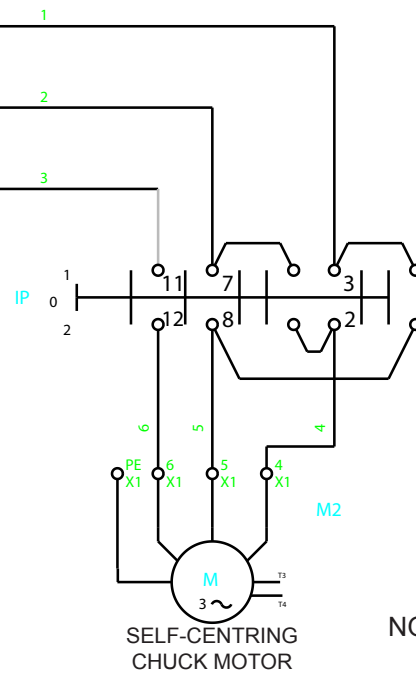

- IP TERMINALS
- \pt10.5;11 = T/L3
 - 7 = S/L2
 - 3 = R/L1
 - 12 = W
 - 8 = V
 - 2 = U

NOTE: DO NOT CONNECT THE THERMAL PROBES



LIST OF COMPONENTS

Drawing N°A - Rev. 0

146605510

WIRING DIAGRAM

Page 38 of 42

TYRE-CHANGER SERIES
NAV26HW - GRS926 -
GGRS926

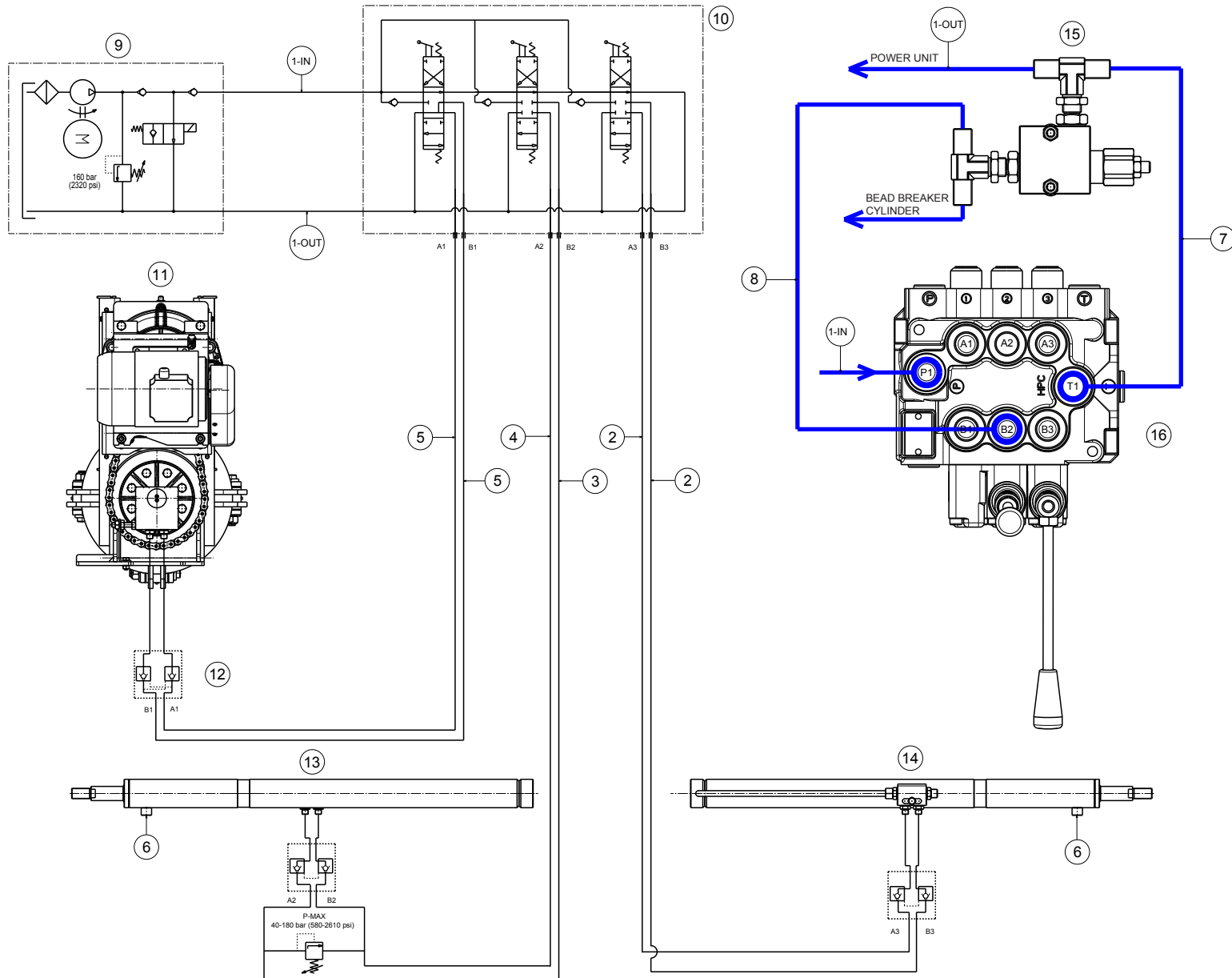

Content of the EC declaration of conformity (with reference to point 1.7.4.2, letter c) of directive 2006/42/EC)

With reference to annex II, part 1, section A of directive 2006/42/EC, the declaration of conformity accompanying the machinery contains:

1. the business name and full address of the manufacturer and, where applicable, its authorised representative;
See the first page of the manual
2. name and address of the person authorised to compile the technical file, who must be established in the Community;
It coincides with the manufacturer, see the first page of the manual
3. description and identification of the machine, including generic name, function, model, type, serial number, trade name;
See the first page of the manual
4. a statement explicitly declaring that the machinery is in conformity with all the relevant provisions of this directive and, where appropriate, a similar statement declaring conformity with other community directives and/or relevant provisions with which the machinery complies. These references must be those of the texts published in the Official Journal of the European Union;
The machinery must comply with the following applicable Directives:

2006/42/CE	Machinery Directive
2014/30/EU	Electromagnetic Compatibility Directive
5. where appropriate, the name, address and identification number of the notified body which carried out the EC type-examination referred to in annex IX and the number of the EC type-examination certificate;
N/A
6. where appropriate, the name, address and identification number of the notified body which approved the full quality assurance system referred to in annex X;
N/A
7. where appropriate, reference to the harmonised standards referred to in article 7, paragraph 2, which have been applied;

UNI EN ISO 12100:2010	Safety of machinery - General principles for design - Risk assessment and risk reduction;
CEI EN 60204-1:2018	Safety of machinery - Electrical equipment of machines - Part 1: General requirements
8. where appropriate, reference to other standards and technical specifications applied;

UNI EN 17347:2001	Road vehicles – Machines for mounting and demounting vehicle tyres – Safety requirements
--------------------------	---
9. place and date of declaration;
Ostellato, / /
10. identification and signature of the person authorised to draw up the declaration on behalf of the manufacturer or its authorised representative.
SIMONE FERRARI VP VSG Europe Managing Director

Content of the declaration of conformity (with reference to Schedule 2, Part 1, Annex I, point 1.7.4.2, letter c) of UK Statutory Instrument 2008 No. 1597)

With reference to schedule 2 annex I, part1, section A of UK Statutory Instrument 2008 No. 1597, the declaration of conformity accompanying the machinery contains:

1. the business name and full address of the manufacturer and, where applicable, its authorised representative;
Manufacturer: see the first page of the manual.
Authorised representative:
VEHICLE SERVICE GROUP UK LTD
3 Fourth Avenue - Bluebridge Industrial Estate - Halstead
Essex CO9 2SY - United Kingdom
2. name and address of the person authorised to compile the technical file;
It coincides with the authorized representative, see point 1
3. description and identification of the machine, including generic name, function, model, type, serial number, trade name;
See the first page of the manual
4. a sentence expressly declaring that the machinery fulfils all the relevant provisions of these Regulations and where appropriate, a similar sentence declaring the conformity with other enactments or relevant provisions with which the machinery complies;
The machinery complies with the following applicable UK Statutory Instruments:
The Supply of Machinery (Safety) Regulations 2008
The Electrical Equipment (Safety) Regulations 2016
The Electromagnetic Compatibility Regulations 2016
5. where appropriate, the name, address and identification number of the approved body which approved the full quality assurance system referred to in Annex X (Part 10 of this Schedule);
N/A
6. where appropriate, the name, address and identification number of the approved body which approved the full quality assurance system referred to in Annex X (Part 10 of this Schedule);
N/A
7. where appropriate, a reference to the designated standards used;

BS EN ISO 12100:2010	Safety of machinery - General principles for design - Risk assessment and risk reduction;
BS EN 60204-1:2018	Safety of machinery - Electrical equipment of machines. General requirements.
BS EN 61000-6-3:2007 +A1:2011 +AC:2012	Electromagnetic compatibility (EMC) - Part 6-3. Generic standards - Emission standard for residential, commercial and light-industrial environments.
BS EN 61000-6-2:2005 +AC:2005	Electromagnetic compatibility (EMC) - Part 6-2. Generic standards - Immunity for industrial environments.
8. where appropriate, reference to other standards and technical specifications applied;
N/A
9. place and date of declaration;
Ostellato, / /
10. identification and signature of the person authorised to draw up the declaration on behalf of the manufacturer or its authorised representative.
SIMONE FERRARI VP VSG Europe Managing Director