

**WHEEL ALIGNERS**  
CCD truck wheel aligners

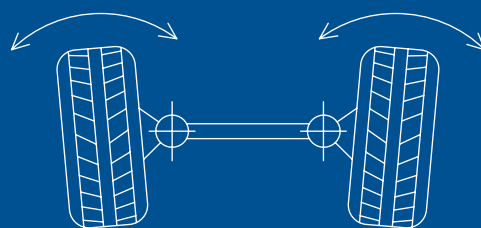

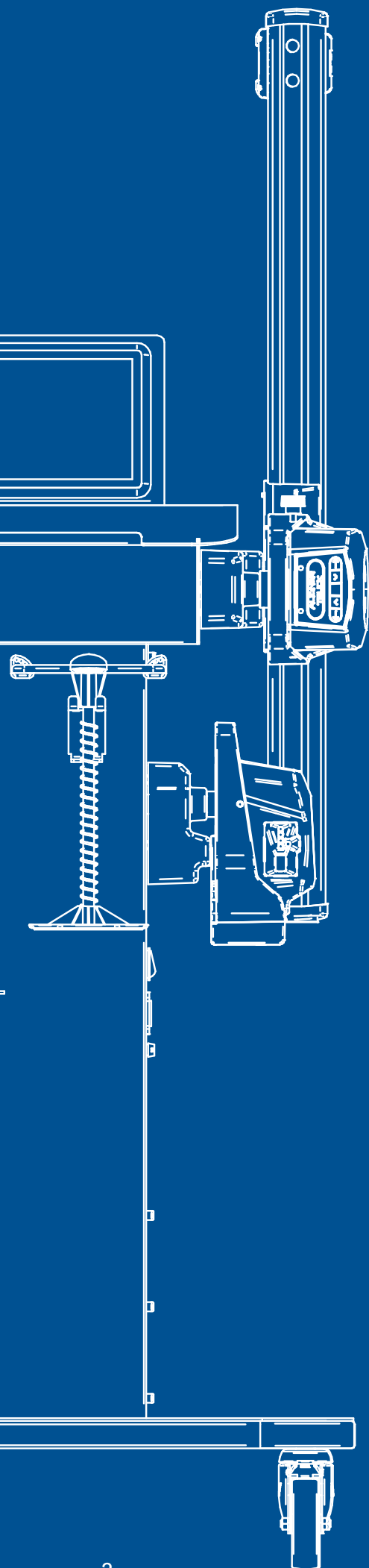

## **Practicality within reach:**

all alignment activities can be controlled from a 11.6" tablet that the operator can carry with him or place on the lift

## **Portability without compromise:**

the new light and compact CCD measuring heads offer maximum convenience

## **Smart technology:**

software with updated graphics, intuitive user interface, animations and adjustment aids so work is rapid and effective



Truck wheel aligners **equipped with CCD sensors, with data transmission via Bluetooth** and powered by fast-charge batteries. The operator is able to have extensive mobility between multiple work stations by controlling all diagnosis procedures from the tablet.

## WHEEL ALIGNERS

CCD truck wheel aligners



**The three LEDs** positioned on the measuring heads aid the procedure during diagnosis.

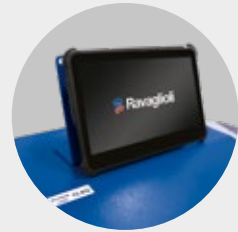

The trailer-mounted console contains recharging supports for measuring heads and tablet.



**Lowered measuring heads** ideal for lorries and buses.

**The fast-charge docks for the battery** of the measuring heads are positioned on the sides of the console, making them accessible and easy to use.

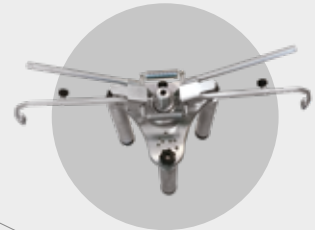

**The STDA92 3-point clamps** allow the off-centre compensation procedure to be eliminated (for model RAVTD6000TWSR.3 only).

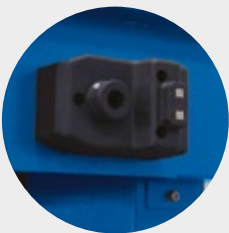

**Infrared transmission** between measuring heads, effective even in critical lighting conditions.

**Bluetooth transmission** between CCD measuring heads and tablet.

**Tablet features:**

 Tablet features: dust- and water- resistant (IP65)	 Resistant to falls up to 1.2 m	 8 GB memory
 Display 1820 x 1080	 Complete with adhesive magnets	 Weighs less than 800 g
 Wi-Fi 802.11 ac/a/b/g/n + Bluetooth		



The Movie program makes recording easier as its 3D animated graphics guide the operator during the procedure.

**Vehicles with multiple axles can be measured simply and quickly.**

The guided procedure is easy to follow, even for less experienced operators.

Program for managing and displaying data in Microsoft Windows environment.

International data bank with vehicle technical data sheets and possibility to create a customer database for adjustment recording.

The measuring heads complete with keyboard offer simple and intuitive remote control, without the need to access the tablet.



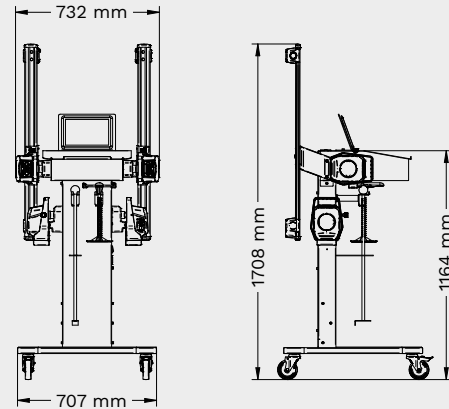







# Technical data

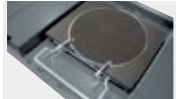

OVERVIEW OF THE MODELS			STANDARD EQUIPMENT	
	Item no.	Colour	Console composition	CCD sensors
RAVTD6000TWSR.3	RAV.TD600.701596	RAL5005	STDA92 clamps and ST-DA29L turntables	6
RAVTD6000TWSR	RAV.TD600.701602	RAL5005	without clamps and turntables	6

	RAVTD6000TWSR.3	RAVTD6000TWSR
Individual toe front/rear axle	+/- 20°	+/- 20°
Total toe	+/- 20°	+/- 20°
Toe-out on turns	+/- 20°	+/- 20°
Camber front/rear axle	+/- 10°	+/- 10°
Caster	+/- 18°	+/- 18°
SAI	+/- 18°	+/- 18°
Set-back	+/- 5°	+/- 5°
Set-back front axle	+/- 5°	+/- 5°
Min. tyre size	12"	12"
Max. tyre size	28"	28"
Wheel diameter max.	1220 mm	1220 mm
Max. wheel base	4500 mm	4500 mm
Display	LCD	LCD
Display size	12"	12"
Network compatible	yes	yes
Data transmission type	cordless	cordless
Measuring system	CCD	CCD
Sensor count	6	6
Power supply	230 V   50 - 60 Hz	230 V   50 - 60 Hz
Width	732 mm	732 mm
Depth	707 mm	707 mm
Height	1708 mm	1708 mm
Weight	97 kg	53 kg

# Accessories

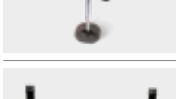
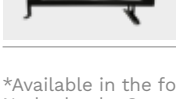
		RAVTD6000TWSR.3	RAVTD6000TWSR
	<b>STDA30E</b> Pair of 4-point truck self-centering clamps, for 12' - 28' rims Movable shaft. Tyre diameter min. 700 mm	<b>O</b>	<b>O</b>
	<b>STDA48E</b> Pair of 4-point truck self-centering clamps with quick-locking arms, for rims from 12' to 28' Movable shaft. Tyre diameter from 780 to 1220 mm	<b>O</b>	<b>O</b>
	<b>STDA92</b> Pair of 3-point truck clamps with quick-locking arms, clamping on rim flange Tyre diameter from 890 to 1290 mm	<b>S</b>	<b>O</b>
	<b>STDA29L</b> Pair of turn tables for commercial vehicles	<b>S</b>	<b>O</b>
	<b>STDA124</b> Pair of 3D turn tables Standard on 3D models	<b>O</b>	<b>O</b>
	<b>STDA110</b> Vehicle data bank	<b>S</b>	<b>S</b>
	<b>STDA141</b> Token (software licence) to use with on smartphones/tablets	<b>O</b>	<b>O</b>
	<b>STDA141ADAS</b> Advanced enabling of ADAS functions	<b>O</b>	<b>O</b>
	<b>STDAShoot</b> Token for consulting database on-line*	<b>O</b>	<b>O</b>
	<b>10479</b> Brake pedal depressor	<b>S</b>	<b>S</b>
	<b>STDA161</b> Steering wheel lock	<b>S</b>	<b>S</b>
	<b>STDA163</b> Calibration kit	<b>O</b>	<b>O</b>

\*Available in the following countries: Denmark, the Netherlands, Germany (KBA), Sweden, Italy, Spain, Portugal, Ireland, New Zealand, Australia, Norway and Finland.

**S** Standard    **O** Optional



### **RAV Italy**

Vehicle Service Group Italy S.r.l.

Via Filippo Brunelleschi 9  
44020 Ostellato (FE)  
Italy

☎ +39.051.6781511  
☎ +39.051.846349  
✉ rav@ravaglioli.com

### **RAV France**

RAV France SARL

4, Rue De Longue Raie  
ZAC de la Tremblaie  
91220 Le Plessis Pâté  
France

☎ +331.60.86.88.16  
☎ +331.60.86.82.04  
✉ rav@ravfrance.fr

### **RAV Germany**

BlitzRotary GmbH

Hüfingener Straße 55  
78199 Bräunlingen  
Germany

☎ +49.771.9233.0  
☎ +49.771.9233.99  
✉ ravd@ravaglioli.com

### **RAV UK**

Vehicle Service Group UK Ltd

3 Fourth Avenue,  
Bluebridge Industrial Estate  
Halstead, Essex, CO9 2SY  
United Kingdom

☎ +44.1787.477711  
☎ +44.1787.477720  
✉ rav@ravaglioli.com

DRF24U(01)

