



# Ravaglioli

COMPANY WITH  
QUALITY SYSTEM  
CERTIFIED BY DNV GL  
= ISO 9001 =

## OPEN FRONT

SOLLEVATORI A 4 COLONNE

4-POST LIFTS

4-SÄULEN-HEBEBÜHNEN

ELEVATEURS A 4 COLONNES

ELEVADORES DE 4 COLUMNAS

### RAV

### 45060F

### 45060FSI

### OPEN FRONT



Versione per misurazione assetto ruote  
*Wheel alignment version*  
Version für die Achsvermessung  
*Version pour contrôle de géométrie*  
Version alineado de dirección

**60**  
SINCE 1958

La lunghezza delle pedane di 5700 mm e la notevole distanza interno colonne garantiscono il sollevamento ottimale di veicoli commerciali di notevoli dimensioni.

*The 5700 mm long platforms and the large inner distance between posts allow optimum lifting of light commercial vehicles and long-wheelbase vans.*

Die Länge der Fahrschienen von 5700 mm und der erhebliche interne Abstand der Hebesäulen gewährleisten ein optimales Heben von Lieferfahrzeugen mit großen Abmessungen.

*La longueur des chemins de roulement de 5700 mm ainsi que la distance considérable à l'intérieur des colonnes garantissent le levage optimal de véhicules commerciaux de grandes dimensions.*

La longitud de las plataformas de 5700 mm y la notable distancia entre las columnas garantizan el levantamiento óptimo de vehículos comerciales de notables dimensiones.



**OPEN FRONT**

Accesso totale alla zona di lavoro  
*Full access to the working area*  
Komplett freier Zugang im Arbeitsbereich  
*Accès complètement libre à la zone de travail*  
Acceso total al área de trabajo



## RAV45060F / 5000 kg - 5700 mm

Pedane per assetto totale extralunghe con sedi anteriori per piatti rotanti e piani oscillanti posteriori.

*Extra-long platforms for total wheel alignment with front turning plates locations and rear slip plates.*

Extra lange Fahrschienen für die gesamte Achsvermessung, vorne mit Aussparungen für Drehplatten und hinten mit Schwingplatten

*Chemins de roulement pour géométrie totale extra-longs avec logements avant pour plateaux pivotants et plans mobiles arrière.*

Plataformas para alineación total extra-largas con asientos para platos giratorios delanteros y platos oscilantes traseros



RAV 45060F

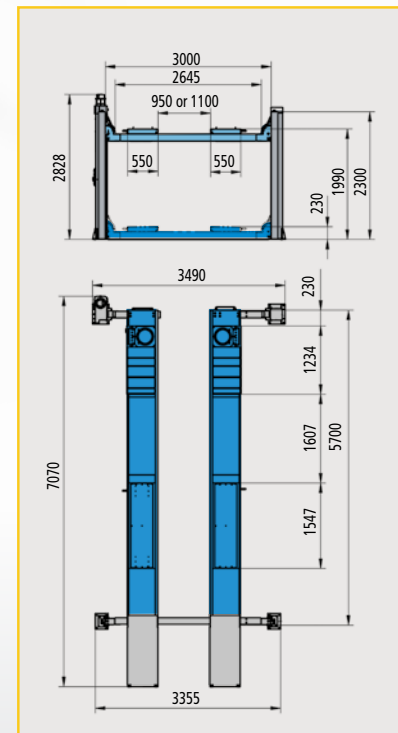

**MULTI - POSITION**





## RAV 4506 OF SI / 5000 kg - 5700 mm

**Pedane per assetto ruote**, con sedi anteriori per piatti rotanti e piani oscillanti posteriori.

**Platforms for total wheel alignment**, with front turning plates recesses and rear slip plates.

**Fahrschienen für die Achsvermessung**, vorne mit Sitzen für Drehteller und hinten mit Schiebeplatten.

**Chemins de roulement pour géométrie**, avec logements avant pour plateaux pivotants et plans mobiles arrière.

**Plataformas para alineación**, con asientos para platos giratorios delanteros y platos oscilantes traseros



RAV 4506 OF SI  
 + VAR4400A9  
 + S110A7

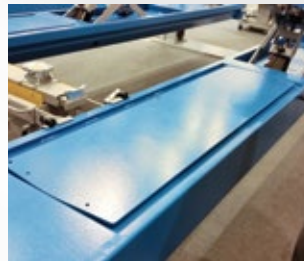
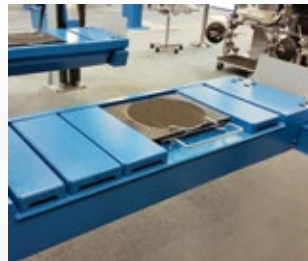

**Piani oscillanti posteriori** a bassissimo attrito, con bloccaggio manuale in posizione centrata e movimenti di oscillazione angolare e trasversale in entrambe le direzioni.

**Low-friction rear slip plates.** They can be manually locked in the central position. Transverse and angular movements in both directions.

**Hintere Schiebeplatten** mit niedrigem Reibungsgrad, manueller Blockierung in zentrierter Position und Schwingbewegungen über Eck- und Querlaufend in beide Richtungen.

**Plans mobiles arrière** à très faible frottement, avec blocage manuel en position centrée et mouvement angulaire et transversal dans les deux directions.

**Platos traseros** con bajo nivel de fricción, bloqueo manual en posición centrada y movimientos de oscilación angular y transversal en ambas direcciones.

### RAV 4506 OF SI

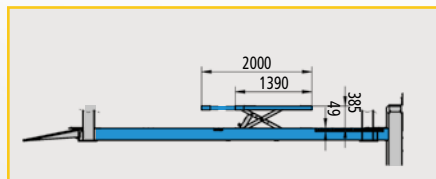
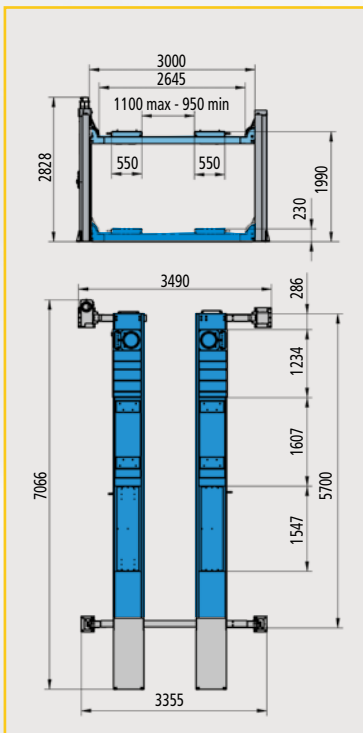

### LIFT TABLE



## OPTIONS

### S4352SIA3



Rampe extralunghe  
Long run up ramps  
Lange Auffahrampen  
Rampes longues  
Rampas larga

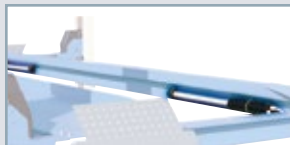

**VAR4400A9**  
Impianto di illuminazione  
Lighting kit  
Beleuchtung  
Système d'éclairage  
Instalación de alumbrado

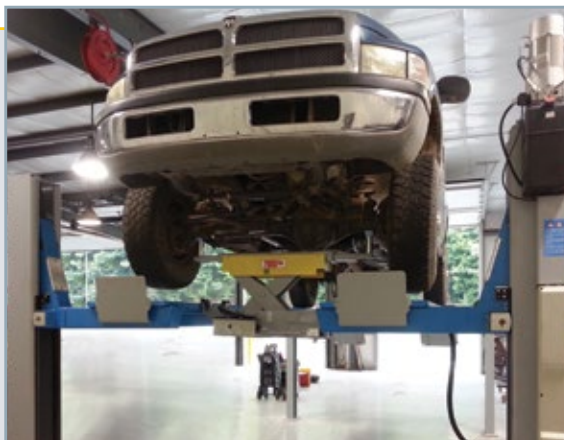

Traverse  
Jacking beams  
Achsheber  
Traverses  
Gatos

## OPTIONS RAV 4505OFSI - RAV 4605OFSI

<b>S505A1</b> (4 x kit)	H= 200 mm	
<b>S505A5</b>	H= 120 mm	
<b>S505A9</b>	H= 60 mm (standard)	
<b>S505A6</b>	H= 40 mm	
<b>S505A7</b> (4 x kit)	H= 20 mm	



### S505A2 (2 x kit)

Traverse / Cross members  
Querstreben / Traverses / Traviesas

Selettore per sollevamento ponte principale o sollevatore integrato.  
Switch to operate main lift of wheel free lift

Schalthebel für Haupthebebühne bzw. Radfreiheber.  
Selecteur pour actionnement du pont ou du levage auxiliaire

Selector para elevación del elevador principal o de la doble elevación

Pulsante di salita  
Lifting button  
Hebeknopf  
Commande de montée  
Pulsador de subida

Pulsante di discesa  
Lowering button  
Senkknopf  
Commande de descente  
Pulsador de bajada

Interruttore generale  
Main switch  
Hauptschalter  
Interrupteur principal  
Interruptor general

Pulsante di parcheggio per assetto ruote  
Parking button for wheel alignment  
Parkknopf für Achsmessstellung  
Commande de positionnement sur crémaillère pour contrôle de géométrie  
Pulsador de parking para alineado de ruedas (RAV4506OFSI)

Struttura rinforzata  
Extra strength structure  
Sehr robuste Struktur  
Structure renforcée  
Estructura reforzada



#### Ravaglioli S.p.A.

via 1° maggio 3  
Fraz. Pontecchio M.  
40037 Sasso Marconi BO - Italia  
Phone +39.051.6781511  
Fax. +39.051.846349  
E-mail: rav@ravaglioli.com

#### RAV France

4, Rue Longue Raie  
ZAC de la Tremblaye  
91220 Le Plessis Pâté  
Phone 01.60.86.88.16  
Fax. 01.60.86.82.04  
E-mail: rav@ravfrance.fr

#### Ravaglioli in Germany

Vehicle Service Group  
Hüfanger Straße 55  
78199 Bräunlingen - Germany  
Phone +49.771.9233.0  
Fax. +49.771.9233.99  
E-mail: ravid@ravaglioli.com

#### Ravaglioli in UK

Vehicle Service Group UK Ltd  
3 Fourth Avenue, Bluebridge Industrial Estate  
Halstead, Essex, CO9 2SY, UK  
Phone +44.1787.477711  
Fax. +44.1787.477720  
E-mail: rav@ravaglioli.com

DRD23U (04)

Le caratteristiche tecniche e gli allestimenti presentati in questo prospetto possono subire variazioni. Le immagini riprodotte non sono vincolanti.

Technical data and composition presented in this catalogue may vary. Pictures reproduced are only indicative.

Die techn. Daten und die Ausrüstungen, die in diesem Prospekt enthalten sind, können Änderungen erfahren. Deshalb sind die Abbildungen unverbindlich.

Les caractéristiques techniques et les compositions présentées dans ce prospectus peuvent subir des variations. Les images reproduites n'ont qu'une valeur indicative.

Las características técnicas y las composiciones ilustradas en este folleto pueden sufrir variaciones. Las imágenes propuestas son solamente indicativas.

Member of VSG - Vehicle Service Group  
a company